

Technical Notes

Application Notes

Storage, MSL, and Humidity Conditions

SMD LEDs are considered moisture sensitive and storage/usage precautions must be taken to prevent damage to the internal materials. Excess moisture trapped within the component may cause internal vapor pressure during solder reflow leading to possible delamination of the die or wire bond.

1. Do not store LEDs in an environment where high levels of moisture or corrosive gases are present and keep away from rapid transitions in ambient temperature. Recommended storage conditions for each type of LED product as per below:

Product Type	Temperature	Humidity
SMD LED	< 40°C	< 90%RH
Through-hole LED	≤ 30°C	< 60%RH
LED Displays	5°C to 30°C	< 60%RH

Note: Above conditions are based on products in original sealed packaging

2. All SMD LEDs are packaged in moisture barrier bags (MBB) with a label indicating the moisture sensitivity level (MSL).
3. Storage conditions for unopened MBB: Temperature < 40°C, Humidity < 90%RH
4. Floor life for opened MBB follows the corresponding MSL as per below:

IPC/JEDEC J-STD-020

MSL	Floor Life	
	Time	Conditions
1	Unlimited	≤30°C / 85%RH
2	1 Year	≤30°C / 60%RH
2a	4 Weeks	≤30°C / 60%RH
3	168 Hours	≤30°C / 60%RH
4	72 Hours	≤30°C / 60%RH
5	48 Hours	≤30°C / 60%RH
5a	24 Hours	≤30°C / 60%RH
6	Time indicated on label	≤30°C / 60%RH

5. All SMD LEDs are packaged with desiccants and a humidity indicator card (HIC). If the LEDs are not used within the specific floor life or if the HIC has indicated presence of moisture, the following baking procedure must be taken:

Condition	Temperature	Humidity	Bake Duration
LEDs inside carrier tape	60°C ± 3°C	<5% RH	100 hours
LEDs outside carrier tape	110°C	-	10 hours

Cleaning

1. Do not use harsh organic solvents such as acetone, trichloroethylene, Chloroform, and/or diflon solvent for cleaning as they may cause damage or hazing to the LED lens.
2. Recommended solvents for cleaning: deionized water or isopropyl alcohol.
3. Special attention should be taken if other chemicals are used for cleaning as they may damage the epoxy lens or housing.
4. Any cleaning should take place at room temperature and the wash duration should not exceed one minute.
5. Use forced-air drying immediately following water wash to remove excess moisture.

Lead Forming

1. Any lead forming or bending must be done prior to soldering.
2. Avoid bending leads at the same point more than once as it may compromise the integrity of the leads.
3. Minimum clearance of 3mm is required between the base of the LED lens and the bend location. Refer to below diagram (*Fig. 1*).

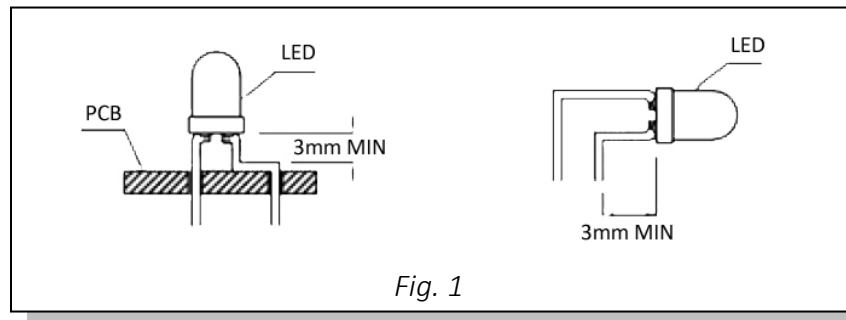

4. Lead forming should only be done with proper tools such as a jig and/or radio pliers. The upper section of the leads should be secured firmly such that the bending force is not exerted on the LED body. Refer to below diagram (*Fig. 2*) for recommended lead bending method.

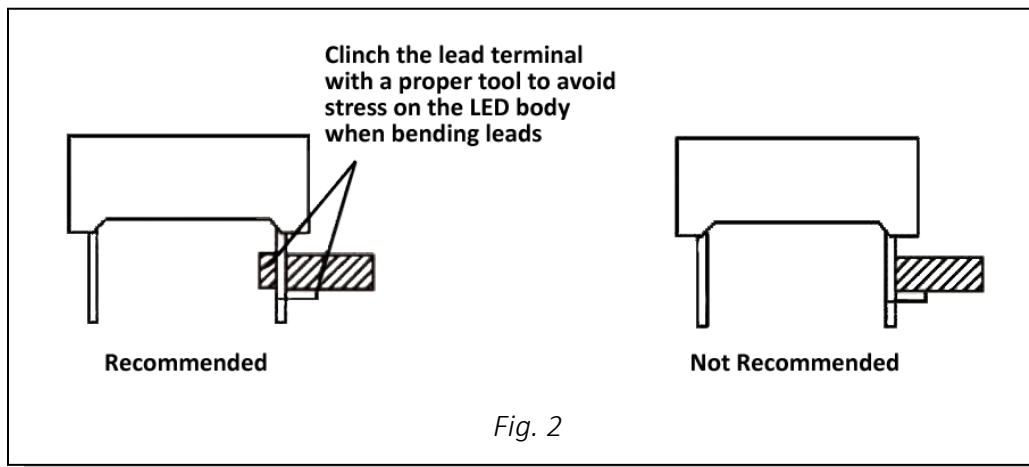

Mounting Methods

1. The LED mounting process should avoid stress applied to the lead terminals.
2. When mounting components for assembly, ensure the terminal pitch matches the hole pitch of the PCB to prevent pressure applied to the LED body due to spreading or pinching of the lead terminals. Refer to below diagram (Fig. 3) for recommended LED mounting method.

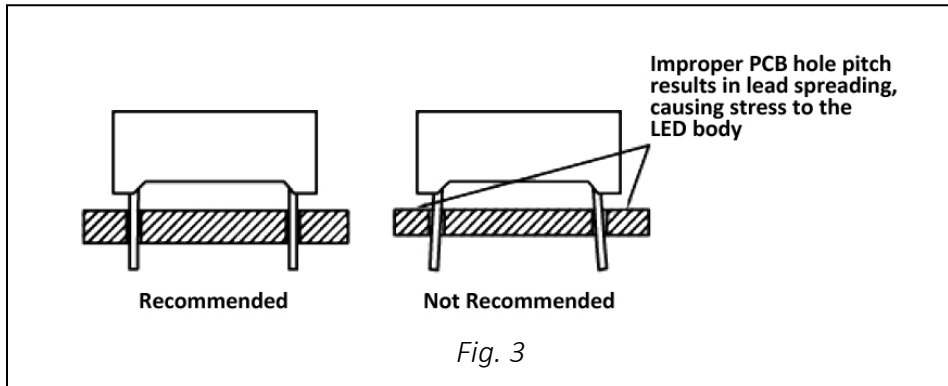

3. To ensure proper mounting, lead forming may be required based upon PCB design layout. All lead forming procedures should follow the lead forming notes as described above. Refer to below diagram (Fig. 4) for examples of proper lead forming.

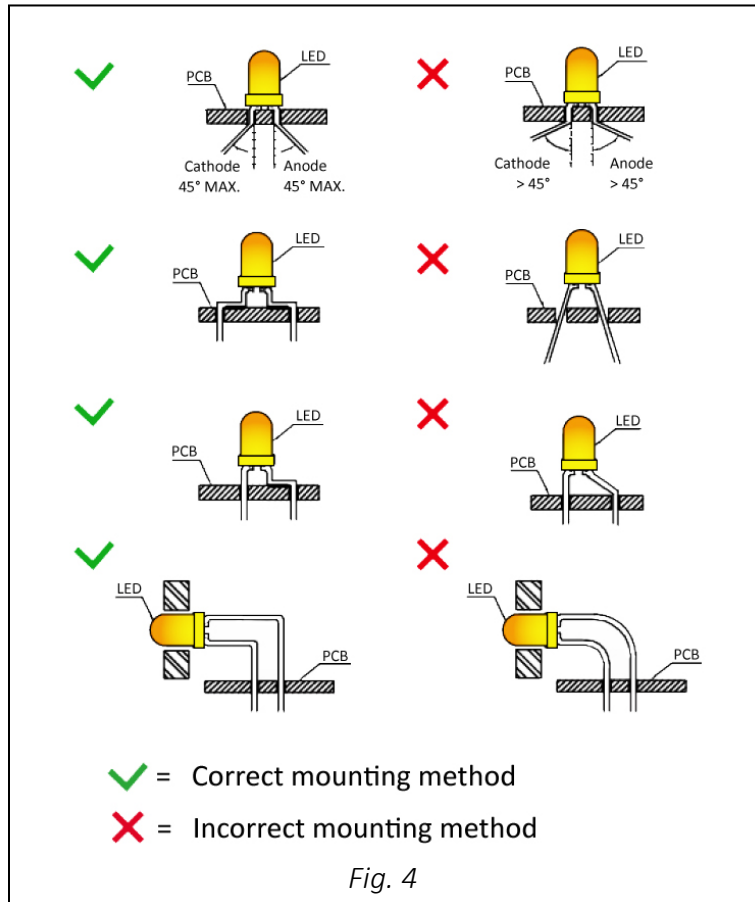

Mounting Methods cont'd

4. Avoid additional lead forming after LEDs have been mounted on the PCB.
5. Stand-offs or spacers should be used if the LED is required to be mounted at a certain height above the PCB.

Soldering

1. Manual soldering operations should only be for repairs and reworks unless otherwise noted on product specifications.
2. Maximum soldering iron temperatures for manual soldering:
 - a. Pb-Sn solder: 300°C
 - b. Pb-Free solder: 350°C
 - c. All LEDs using InGaN material (Blue, Green, White): 280°C
3. The soldering iron should never touch the epoxy lens. Contact duration with the component should not exceed 3 seconds.
4. Do not apply stress or pressure to the leads when the component is heated above 80°C as possible damage to the internal wire bonds may occur.
5. During soldering, component covers and holders should leave enough clearance to avoid any stress applied to the LED. Refer to below diagram (Fig. 5) for examples of proper method.

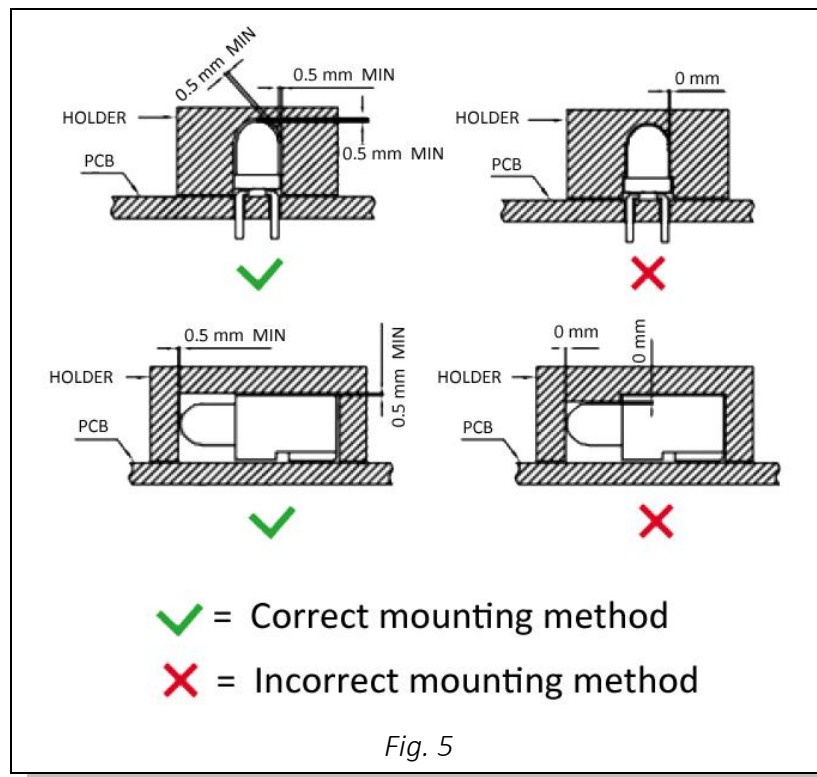

Soldering cont'd

- 6. Refer to below diagrams for recommended soldering profiles.
 - a. SMD LEDs: Reflow Soldering – Pb-Free Solder (Fig. 6) | Pb-Sn Solder (Fig. 7)
 - No more than two soldering passes except SMD CBIs which should not exceed one pass
 - b. Through-hole LEDs: Wave Soldering – Pb-Free Solder (Fig. 8) | Pb-Sn Solder (Fig. 9)
 - No more than one soldering pass

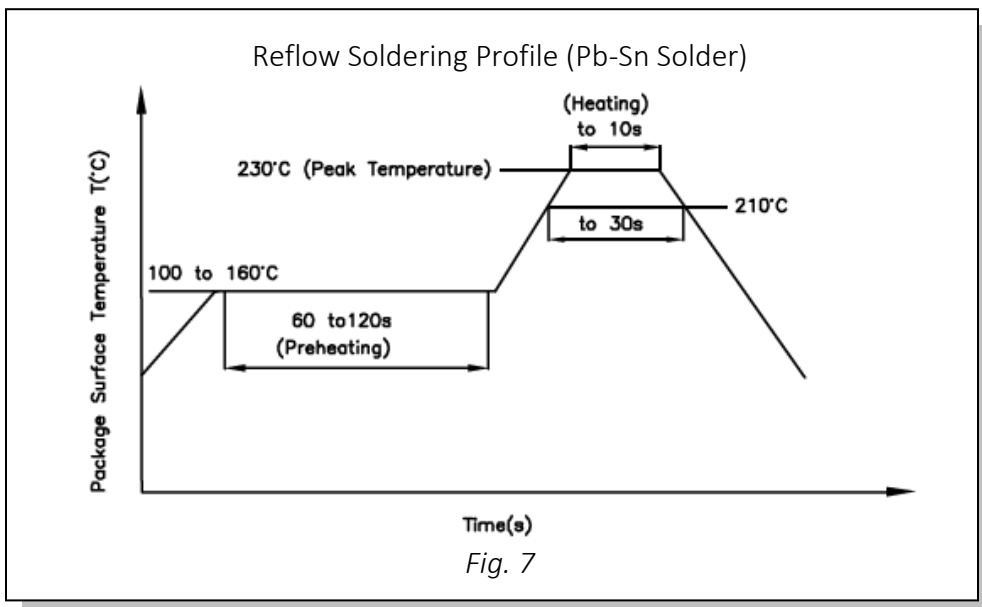
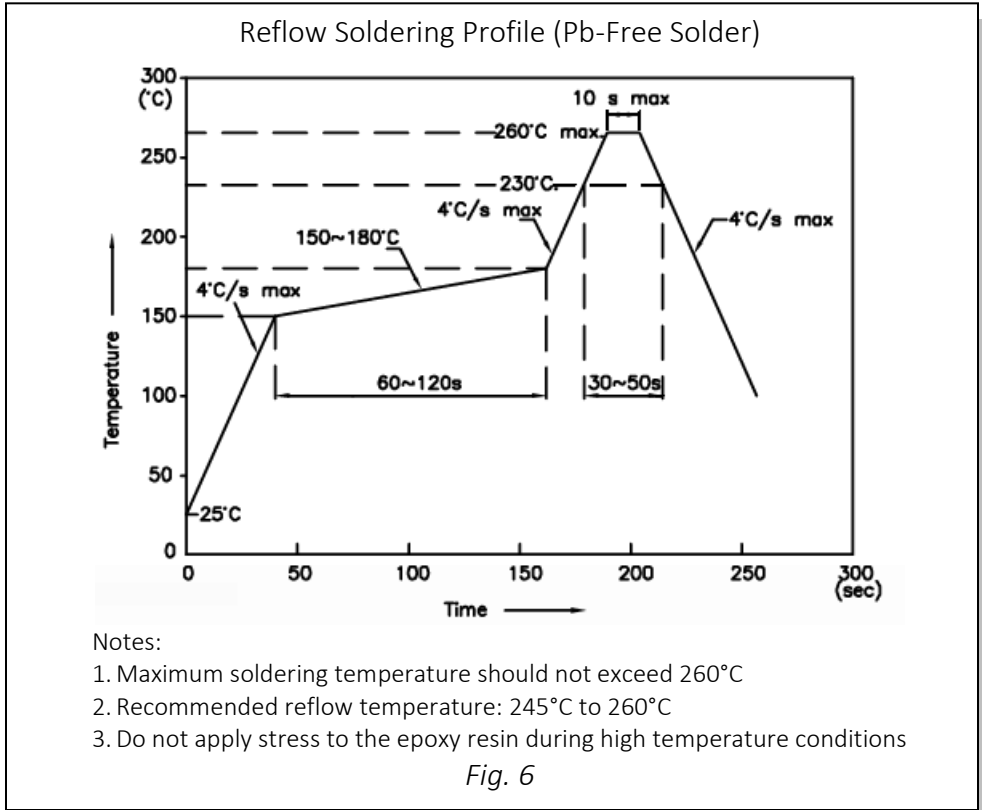

Soldering cont'd (back to top)

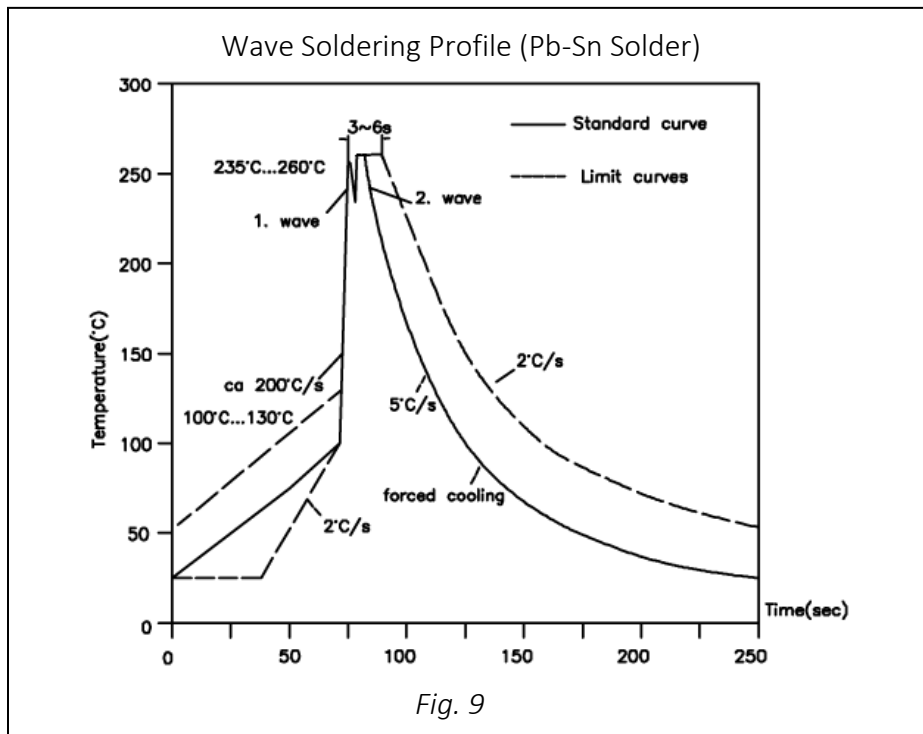
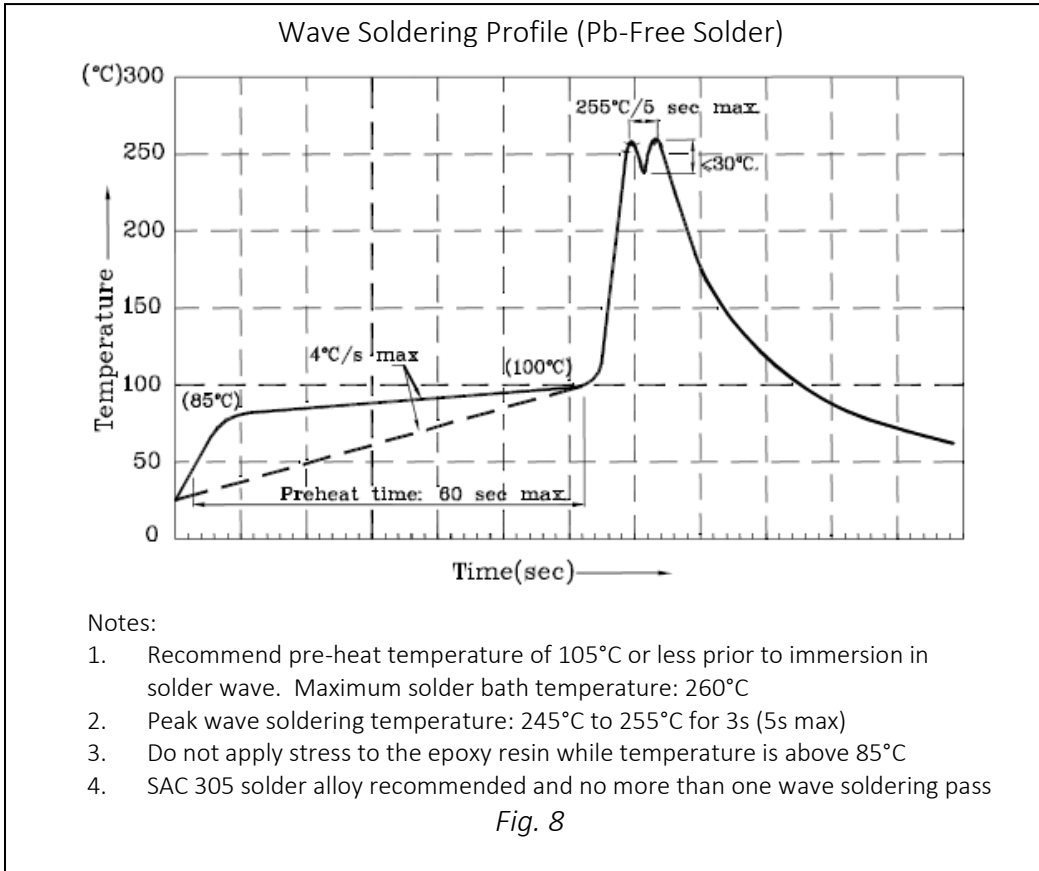

Soldering cont'd

7. Refer to the appropriate product datasheet for details on specific soldering pay layout. To ensure proper bonding and setting of the LED, solder paste must be evenly applied to each soldering pad. Refer to below diagram (*Fig. 10*) for example of improper solder application.

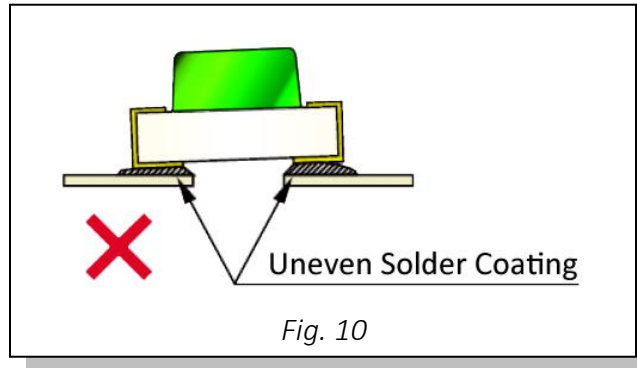

8. After soldering, allow at least three minutes for the component to cool to room temperature before further processing.
9. Refer to below table for summary of soldering instructions for dip, wave, and manual solder. Note that these are considered general instructions and all soldering notes indicated above should take precedence.

Product Type	Dip Soldering / *Wave Soldering			Iron Soldering (with 1.5mm iron tip)		
	Temp. of solder bath	Maximum solder time	Distance (joint-package)	Temp. of solder iron	Maximum solder time	Distance (joint-package)
Through-hole	≤260°C	3s	≥2mm	≤350°C	3s	≥2mm
	≤260°C	5s	≥5mm	≤350°C	5s	≥5mm
SMD	-	-	-	≤350°C	3s (once)	-
Displays	*≤260°C	*3s	*≥2mm	≤350°C	3s	≥2mm

ESD Precautions

InGaN/GaN material LEDs are sensitive to electrostatic discharge (ESD) and other transient voltage spikes. ESD and voltage spikes can affect the component's performance due to increased reverse current and/or decreased forward voltage. This may result in reduced light intensity and/or component failure. Static discharge may occur when static sensitive LEDs come in contact with the user or other conductive devices. ESD sensitive LEDs must incorporate protective circuitry to prevent ESD and to control voltage spikes in order to stay within the maximum voltage specified.

ESD Precautions cont'd

SunLED products are stored in anti-static bags for protection during transportation and storage. However, below anti-static measures should always be noted when handling static sensitive components.

1. Operators must wear anti-static wristbands.
2. Operators must wear anti-static suits when entering work areas with conductive machinery and materials.
3. All test instruments and production machinery must be grounded.
4. Avoid static build up by minimizing friction between the LED and its surroundings.
5. Humidity level should be maintained at 50% or higher in a production environment.
6. All workstations that handle ESD sensitive components must maintain an electrostatic condition of 150V or less.
7. All anti-static measures noted above should be periodically checked and inspected to ensure proper functionality.

Design Notes

1. Protective current-limiting resistors should be used in conjunction with LEDs to ensure parts are operating within specified current range.
2. The driving circuit should be designed to avoid reverse voltages and transient voltage spikes when the circuit is in both on & off states.
3. When LEDs are mounted in a parallel configuration, there should be individual current-limiting resistors in series with each LED. Refer to below diagram (*Fig. 11*) for an example of a recommended set up.

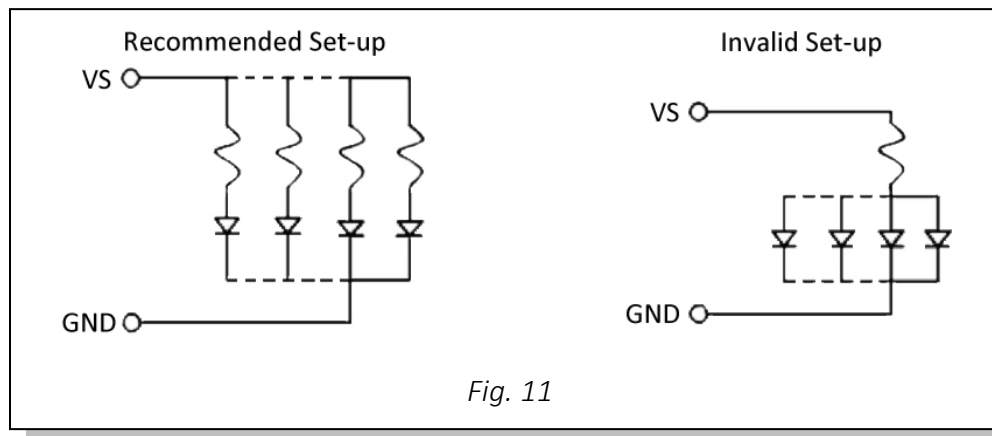

4. Mounting direction of SMD components should be placed perpendicular to the direction of PCB travel. This will ensure the solder wets on each lead simultaneously during reflow and prevent shifting of LEDs. Refer to below diagram (*Fig. 12*) for examples of recommended mounting direction.

Design Notes cont'd (back to top)

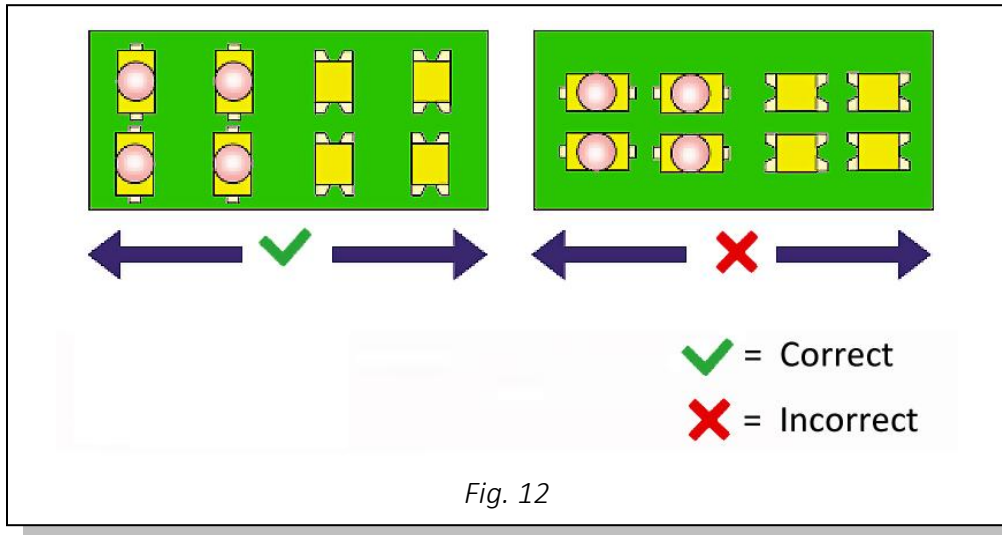

- High-power LED devices require optimization of heat dissipation. Increasing the size of metal mounting surface and proper application of thermal conductive paste will help improve heat dissipation. Refer to below diagram (Fig. 13) and product datasheets for specific design recommendations.

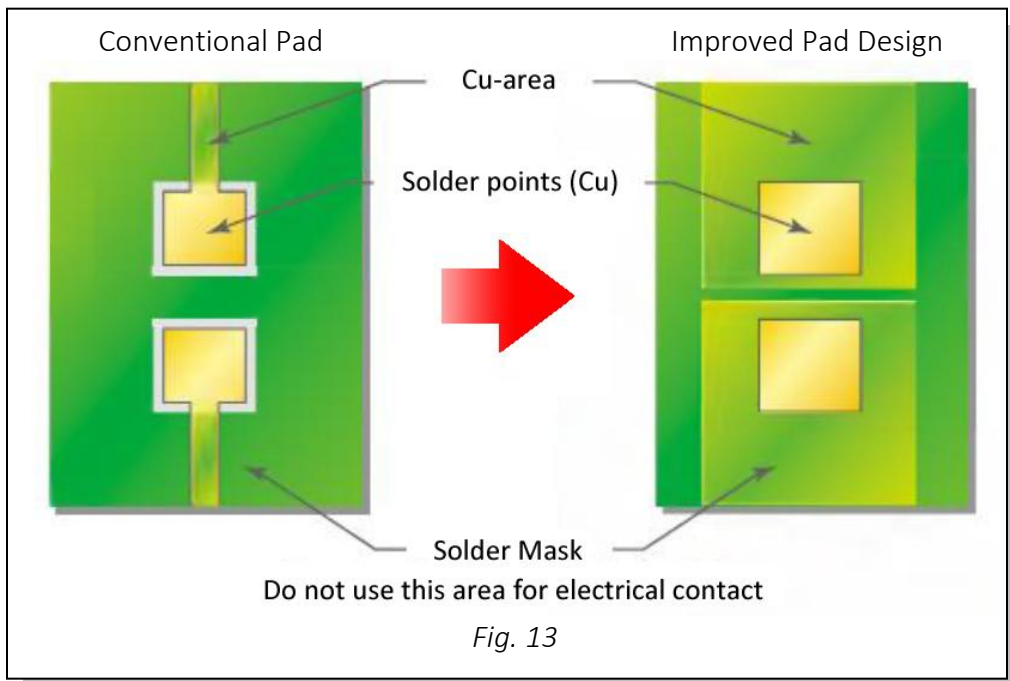

- High temperatures may reduce component's performance and reliability. Please refer to individual product datasheets for specific details on operable temperature range and effects of temperature on the LED.

Additional Remarks

1. LED devices may contain Gallium Arsenide (GaAs). GaAs dust and fumes are toxic and harmful if ingested. Do not expose LEDs to chemical solvents and/or break open LED components.
2. The light output from UV, blue, and high-power LEDs may cause injury to the human eye when viewed directly.
3. Semiconductor devices can fail or malfunction due to their sensitivity to electrical fluctuation and physical stress. In design development, please make certain that SunLED products are used within the specified operating conditions as indicated on our most current product datasheets. The user is responsible to observe and follow all safety measures to avoid situations where the failure or malfunction of a SunLED product could cause injury, property damage, or the loss of human life.
4. SunLED products are bin sorted for intensity and wavelength. To ensure intensity and color consistency when using multiple LEDs in an array, it is recommended to use parts within the same bin code. Each bag, reel, or tube of LEDs contain a single intensity and wavelength code and is indicated on the part number label. Refer to below diagram (Fig. 14) for bin code identification and reference bin code documentation for specification data.

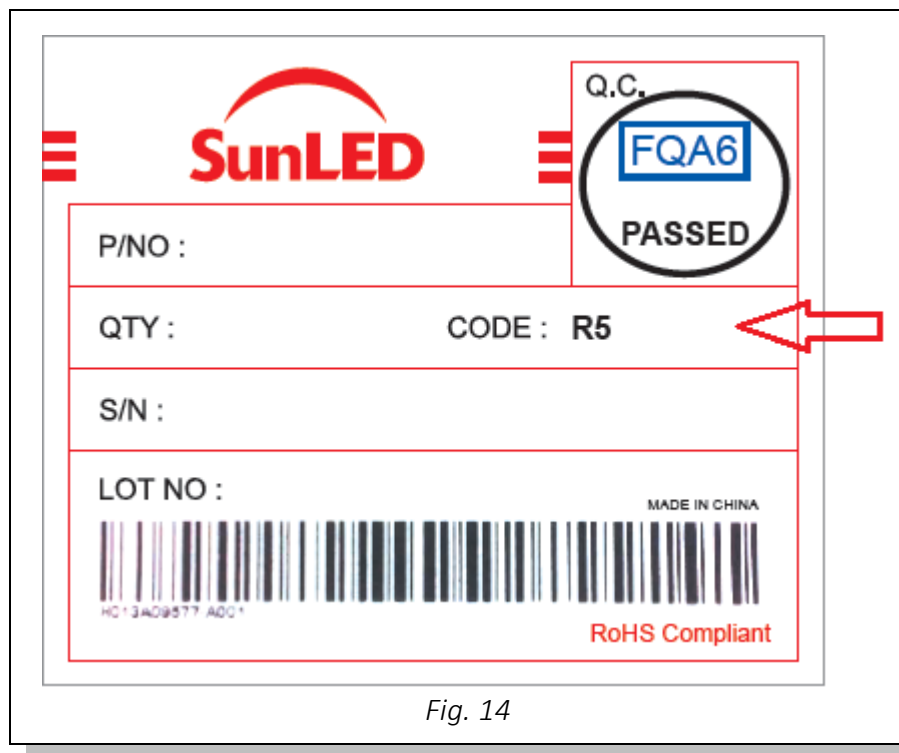

Fig. 14

5. Prolonged reverse bias should be avoided as it could cause metal migration leading to an increase in leakage current or causing a short circuit.
6. Contents within this document are subject to improvement and enhancement changes without notice.