



# ISSI pFlash® Over 4 Billion Units Shipped!

*Here a pFlash®, there a pFlash®,  
Everywhere a pFlash®!*

## ➤ Key features of ISSI 25-Series LD/WD family

Addressing a Serial Flash SAM of 400M\$ for ≤4Mb (TAM: 1.6B\$)

- 256Kb, 512Kb, 1Mb, 2Mb, and 4Mb parts in production
- Industry-standard 8-pin SOIC (208/150 mil), USON, WSON, and thin VVSOP packages available
- Low pin count simplifies board layout, reduces footprint and overall system cost in embedded designs
- Uniform 4 KB sectors for parameter storage
- Software and hardware write protection for enhanced security and IP protection (OTP)
- Fast read performance for quick boot
- Built upon proprietary pFlash® technology

## ➤ pFlash® technology offers:

- Lower power consumption
- High-speed programming
- High-speed erase capabilities
- Industry's best solid data retention (Min 20 years and 200K cycles of endurance)

## ➤ pFlash® Advantage:

- The low programming/erase current enables Test-by-Performance. This comprises of extracting the statistical behavior of all critical parameters and by setting the test specification to remove extrinsic distributions
- pFlash® technology adopts built-in-tests to remove infant mortality by facilitating cell characterization and implementing comprehensive stress modes to provide the lowest DPPM on the market (<0.013 DPPM 2012)

## ➤ Applications:

- pFlash®'s High-Quality and Reliability parts are used in code storage applications in consumer electronics such as: *graphics cards, notebook cameras, PC bios, LCD monitors, HDD, ODD, Bluetooth, cordless phones, NFC, fingerprint, DSC, Zigbee, and various other industrial and medical applications.*
- This family of low-density parts are offered in voltages ranging from 1.8V to 3.6V. With read performances of up to 100Mhz for fast application boot, coupled with industrial temp ranges, high quality, and reliability, it's no wonder ISSI's pFlash® technology is the leading technology of choice for code storage in HDD markets.

## ➤ pFlash® Cell

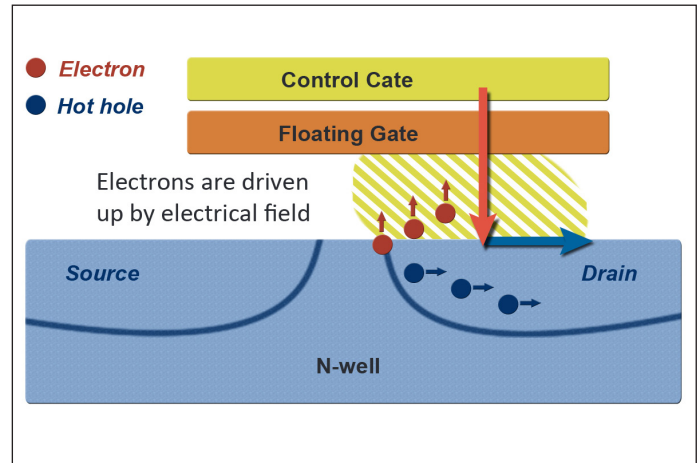

## ➤ pFlash® High Endurance Metrics

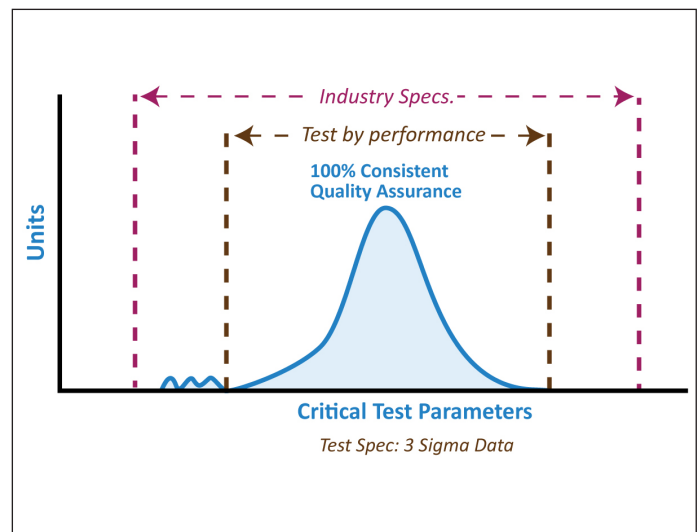

# pFlash® Advantage:

## ➤ pFlash® High Endurance Metrics

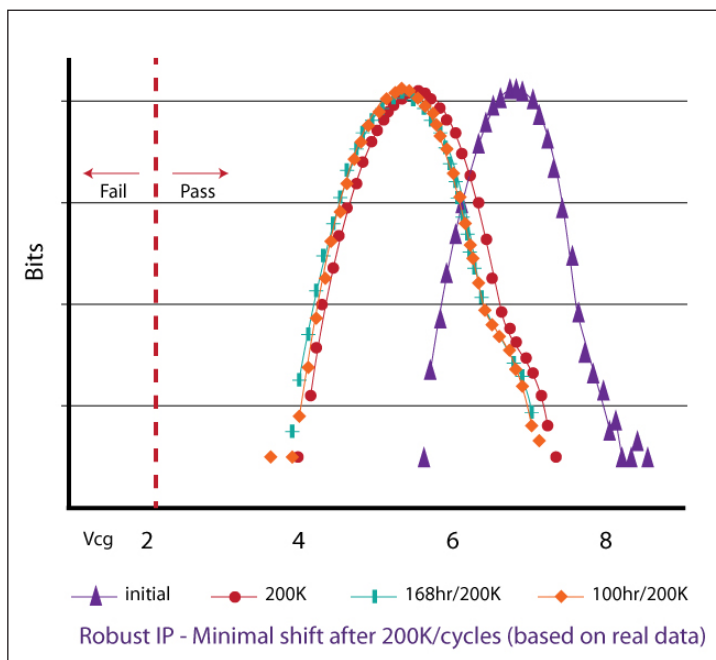

## ➤ pFlash® DPPM (Lowest in the industry)

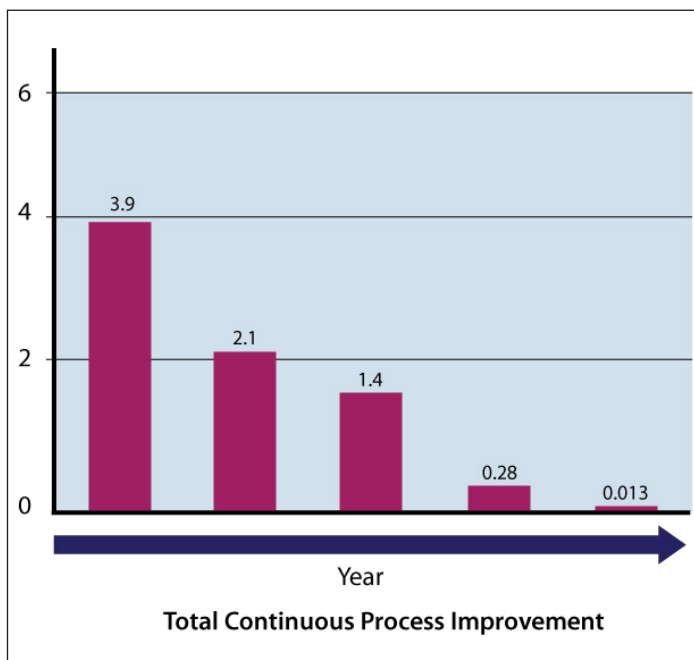

## NOR Serial Flash:

Den	Part No.	Dual SPI	Voltage(V)	Frequency (MHz)	Package Type*	Temperature**	Status
256K	IS25CD025	●	2.7-3.6	33/100	JN, JD	E, A1, A2	Production
512K	IS25CD512	●	2.7-3.6	33/100	JN, JD, JK, JU	E, A1, A2	Production
1M	IS25CD010	●	2.7-3.6	33/100	JN, JD	E, A1, A2	Production
2M	IS25LD020	●	2.3-3.6	33/100	JN, JD, JK JV	E, A1, A2	Production
2M	IS25WD020	●	1.65-1.95	30/80	JN, JB, JK, JV	E, A1, A2	Production
4M	IS25LD040	●	2.3-3.6	33/100	JN, JB, JK, JV	E, A1, A2	Production
4M	IS25WD040	●	1.65-1.95	33/80	JN, JB, JK, JV	E, A1, A2	Production

For KGD or WLCSF contact factory

## Other Flash Products Available from ISSI

### NOR ISA Flash:

Den	Part No.	Type	Voltage(V)	Speed (ns)	Package Type*	Temperature**	Status
512K	IS39LV512	x8	2.7-3.6	70	70JCE, 70VCE	I, A1	Production
1M	IS39LV010	x8	2.7-3.6	70	70JCE, 70VCE	I, A1	Production
4M	IS39LV040	x8	2.7-3.6	70	70JCE, 70VCE	0°C to 85°C	Production

### NOR FWH Flash

Den	Part No.	Type	Voltage(V)	Speed (ns)	Package Type*	Temperature**	Status
4M	IS49FL004T	x8	3.0-3.6	33	33VCE, 33JCE	0°C to 85°C	Production

#### \* Package Types

JN = 8 pin SOIC 150mil  
 JB = 8 pin SOIC 208mil  
 JD = 8 pin TSSOP  
 JK = 8 pin WSON (5x6 mm)  
 JU = 8 pin USON (2x3mm)  
 JV = 8 pin VVSOP 150mil  
 33JCE = 32 pin PLCC  
 33VCE = 32 pin VSOP(8x14mm)  
 70JCE = 32 pin PLCC  
 70VCE = 32 pin VSOP(8x14mm)

#### \*\* Temperature

- I = Industrial grade (-40C to +85C)
- E= Extended grade (-40C to +105C)
- A1 = Automotive grade (-40C to +85C) (Call Factory)
- A2 = Automotive grade (-40C to +105C) (Call Factory)

