



Pushing Performance



People | Power | Partnership

# HARTING

## Circular Connectors

---

**Contents**

Chapter

**Device side**

M8 .....	<b>D03 08</b>
M12 .....	<b>D03 12</b>
M23 .....	<b>D03 23</b>
7/8" HARAX® .....	<b>D03 35</b>
HARAX® panel feed throughs .....	<b>D03 50</b>

**Cable side**

M8 .....	<b>C03 08</b>
M12 .....	<b>C03 12</b>
M23 .....	<b>C03 23</b>
7/8" HARAX® .....	<b>C03 35</b>

<b>Cable assemblies</b> .....	<b>CAB 03</b>
-------------------------------	---------------

<b>Tooling</b> .....	<b>TOO 03</b>
----------------------	---------------

# Transforming customer wishes into concrete solutions



The HARTING Technology Group is skilled in the fields of electrical, electronic and optical connection, transmission and networking technology, as well as in manufacturing, mechatronics and software creation. The Group uses these skills to develop customized solutions and products such as connectors for energy and data-transmission/data-networking applications, including, for example, mechanical engineering, rail technology, wind energy plants, factory automation and the telecommunications sector. In addition, HARTING also produces electro-magnetic components for the automobile industry and offers solutions in the field of housing technology and shop systems.

The HARTING Group currently comprises 58 sales companies and production plants worldwide employing a total of about 5,300 staff.

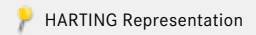
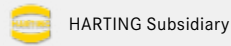

#### We aspire to top performance.

Connectors ensure functionality. As core elements of electrical and optical termination, connection and infrastructure technologies, they are essential in enabling the modular construction of devices, machines and systems across an extremely wide range of industrial applications. Their reliability is a crucial factor guaranteeing smooth functioning in the manufacturing area, telecommunications, applications in medical technology – in short, connectors are at work in virtually every conceivable application area. Thanks to the ongoing development of our technologies, our customers enjoy investment security and benefit from durable, long-term functionality.

#### Wherever our customers are, we're there.

Increasing industrialization is creating growing markets that are characterized by widely diverging demands and requirements. What these markets all share in common is the quest for perfection, increasingly efficient processes and reliable technologies. **HARTING** is providing these technologies – in Europe, the Americas and Asia. In order to implement customer requirements in the best possible manner, the **HARTING** professionals at our international subsidiaries engage in up-close, partnership-based interaction with our customers, right from the very early product development phase.

Our on-site staff form the interface to the centrally coordinated development and production departments. In this way, our customers can rely on consistently high, superior product quality – worldwide.

#### Our claim: Pushing Performance.

**HARTING** provides more than optimally attuned components. In order to offer our customers the best possible solutions, on request **HARTING** contributes a great deal more and is tightly integrated into the value-creation process.

From ready-assembled cables through to control racks or ready-to-go control desks. Our aim is to generate maximum benefit for our customers – with no compromises!

#### Quality creates reliability – and warrants trust.

The **HARTING** brand stands for superior quality and reliability – worldwide. The standards we set are the result of consistent, stringent quality management that is subject to regular certifications and audits.

EN ISO 9001, the EU Eco-Audit and ISO 14001:2004 are key elements here. We take a proactive stance towards new requirements, which is why **HARTING** is the first company worldwide to have obtained the new IRIS quality certificate for rail vehicles.



**HARTING technology creates added value for customers.** Technologies by **HARTING** are at work worldwide. **HARTING's** presence stands for smoothly functioning systems powered by intelligent connectors, smart infrastructure solutions and sophisticated network systems. Over the course of many years of close, trust-based cooperation with its customers, the **HARTING** Technology Group has become one of the leading specialists globally for connector technology. We offer individual customers specific and innovative solutions that go beyond the basic standard functionalities. These tailored solutions deliver sustained results, ensure investment security and enable customers to achieve significant added value.

**Opting for HARTING opens up an innovative, complex world of concepts and ideas.**

In order to develop and produce connectivity and network solutions serving an exceptionally wide range of connector applications in a professional and cost-effective manner, **HARTING** not only commands the full array of conventional tools and basic technologies. Above and beyond these capabilities, **HARTING** is constantly harnessing and refining its broad base of knowledge and experience to create new solutions that also ensure continuity. To secure its lead in know-how, **HARTING** draws on a wealth of sources from its in-house research and applications.

Salient examples of these sources of innovative knowledge include microstructure technologies, 3D design and connection technolo-

gy, high-temperature and ultrahigh-frequency applications that are finding use in telecommunications and automation networks, in the automotive industry, or in industrial sensor and actuator applications, RFID and wireless technologies, in addition to packaging and housing made of plastics, aluminum and stainless steel.

**HARTING overcomes technological limitations.**

Drawing on the comprehensive resources of the group's technology pool, **HARTING** devises practical solutions for its customers. Whether this involves industrial networks for manufacturing automation, or hybrid interface solutions for wireless telecommunication infrastructures, 3D circuit carriers with microstructures, or cable assemblies for high-temperature applications in the automotive industry – **HARTING** technologies offer not only components, but comprehensive solutions attuned to individual customer requirements and preferences. The range of cost-effective solutions covers ready-to-use cable configurations, completely assembled backplanes and board system carriers, as well as fully wired and tested control panels.

In order to ensure the future-proof design of RF and EMC-compatible interface solutions, the central **HARTING** laboratory (certified to EN 45001) employs simulation tools, as well as experimental, testing and diagnostics facilities all the way to scanning electron microscopes. In addition to product and process suitability considerations, lifecycle and environmental aspects play a key role in the selection of materials and processes.

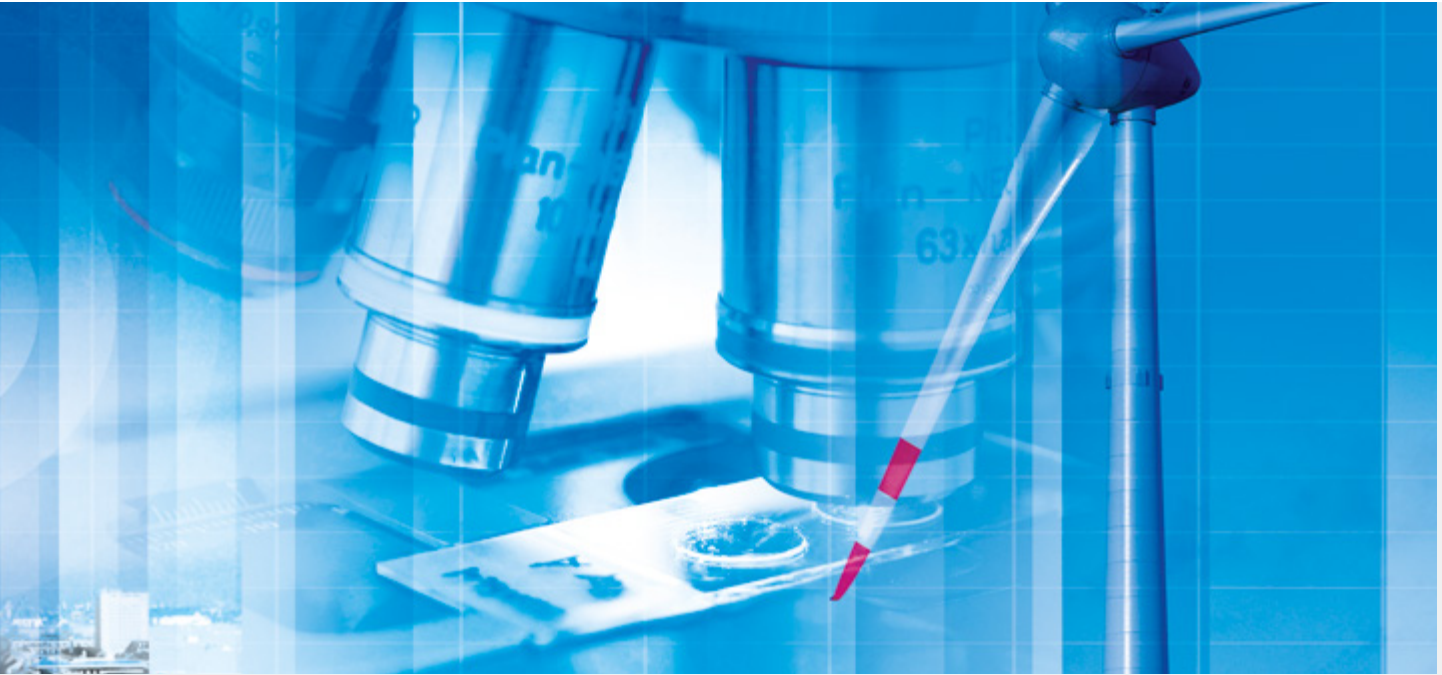

HARTING's knowledge is practical know-how that generates synergy effects.

HARTING commands decades of experience with regard to the applications conditions involved in connections in telecommunications, computer, network and medical technologies, as well as industrial automation technologies, e.g. in the mechanical engineering and plant engineering areas, in addition to the power generation industry and the transportation sector. HARTING is highly

conversant with the specific application areas in all of these technology fields. In every solution approach, the key focus is on the application. In this context, uncompromising, superior quality is our hallmark. Every new solution found invariably flows back into the HARTING technology pool, thereby enriching our resources. And every new solution we go on to create will draw on this wealth of resources in order to optimize each and every individual solution. HARTING is synergy in action.

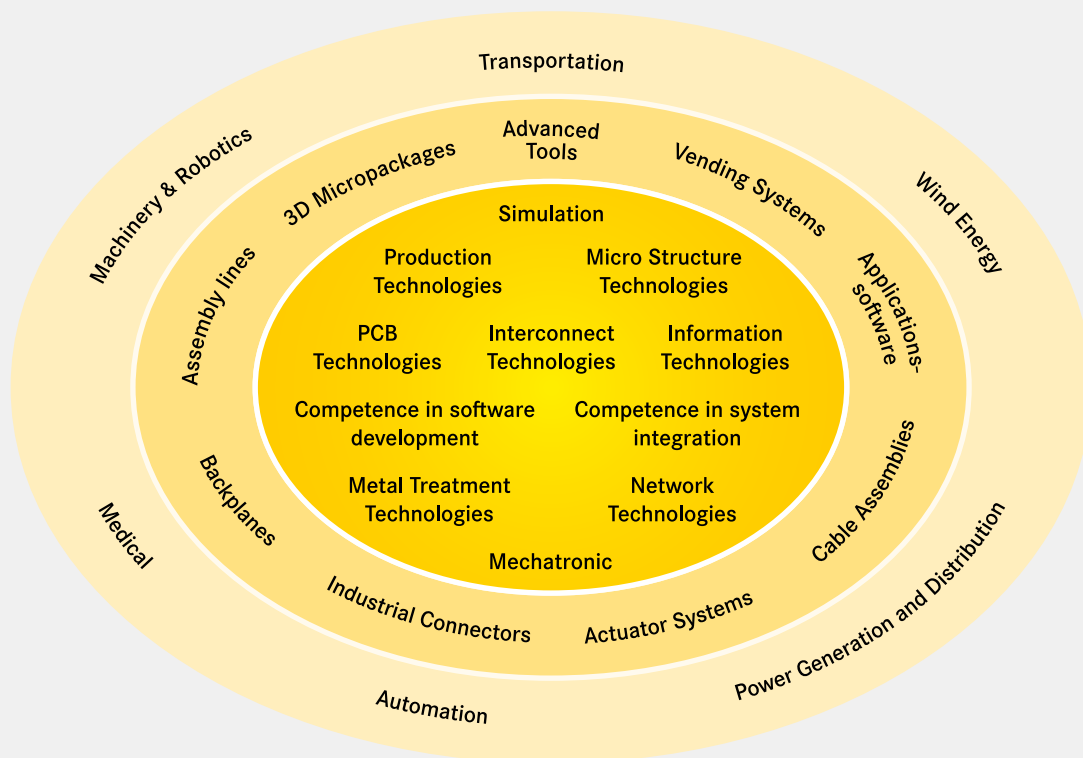



The **HARTING eCatalogue / eShop** can be found on our homepage at [www.HARTING.com](http://www.HARTING.com) or at the direct link [www.eCatalogue.HARTING.com](http://www.eCatalogue.HARTING.com).

The HARTING e-Catalogue is your platform for conveniently selecting individual products as well as configuring complete solutions. Our comprehensive product pages provide you with all necessary technical information and CAD files in various formats for downloading. You may also contact our technical sales department directly.

Find out about **product innovations and news** on the start page of the HARTING e-Catalogue or go directly to [www.product-news.HARTING.com](http://www.product-news.HARTING.com).

Registered users can take advantage of MyHARTING to check on availability or prices, and to place or track their orders. Here, your customized „HARTING history“ provides you with a list of your inquiries, quotations and more.

Sign up now for your free e-Catalogue account at HARTING!

[www.eShop.HARTING.com](http://www.eShop.HARTING.com)

Contents

Page

PCB connectors.....

**D03 08.2**

M8

Panel feed through .....

**D03 08.15**

Accessories .....

**D03 08.17**

Number of contacts

**4**

Reflow soldering termination (THR)  
Shielded

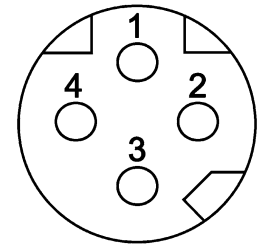

### Technical characteristics

Number of contacts	4
Rated current	4 A
Rated voltage	60 V
Rated impulse voltage	1.5 kV
Pollution degree	3
Insulation resistance	$>10^8 \Omega$
Contact resistance	$\leq 10 \text{ m}\Omega$
Mating cycles	$\geq 100$
Degree of protection acc. to IEC 60529	IP65 / IP67, when mated

### Technical characteristics

Transmission characteristics	Cat. 5, Class D up to 100 MHz
Tightening torque	1 Nm Lock nut
Material (contacts)	Copper alloy
Surface (contacts)	Gold plated
RoHS	compliant with exemption

### Specifications and approvals

IEC 61076-2-114

#### Identification

Circular connectors M8,  
PCB connector,  
Straight,  
Reflow soldering termination (THR),  
Shielded,  
Pack contents:  
50 pieces in a tray



Order housings separately

Circular connectors M8,  
PCB connector,  
Straight,  
Reflow soldering termination (THR),  
Shielded,  
Pack contents:  
25 pieces in a carton box



Order housings separately

Part number  
Female

21 02 381 2418

21 02 381 2419

Drawing  
(dimensions in mm)

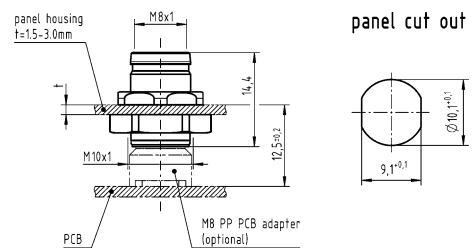

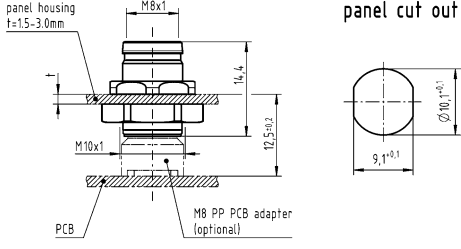
Identification	Part number Female	Drawing (dimensions in mm)
<p>Circular connectors M8, Housing, for front mounting, Pack contents: incl. lock nut</p> 	<p>21 02 301 2001</p>	
<p>Circular connectors M8, Housing, for front mounting, Pack contents: without lock nut</p>	<p>21 02 301 2002</p>	
<p>Lock nut, M10 x 1</p>	<p>21 01 000 0051</p>	

M8

Number of contacts

**4**

Reflow soldering termination (THR)  
Shielded

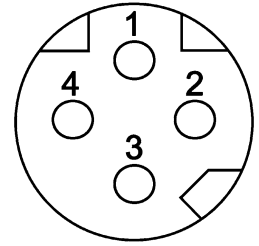

**Technical characteristics**

Number of contacts	4
Rated current	4 A
Rated voltage	60 V
Rated impulse voltage	1.5 kV
Pollution degree	3
Insulation resistance	>10 <sup>8</sup> Ω
Contact resistance	≤10 mΩ
Degree of protection acc. to IEC 60529	IP65 / IP67, when mated
Transmission characteristics	Cat. 5, Class D up to 100 MHz

**Technical characteristics**

Tightening torque	1 Nm Lock nut
Material (contacts)	Copper alloy
Surface (contacts)	Gold plated
RoHS	compliant with exemption

**Specifications and approvals**

IEC 61076-2-114

**Identification**

Circular connectors M8,  
PCB connector,  
Straight,  
for front mounting,  
Reflow soldering termination (THR),  
Shielded,  
Pack contents:  
incl. housing



Part number  
Female

21 02 381 2431

Drawing  
(dimensions in mm)

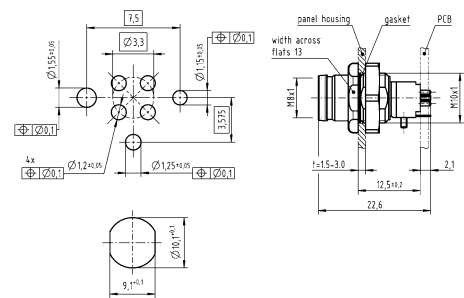

Number of contacts

**4**

Wave soldering termination  
Shielded

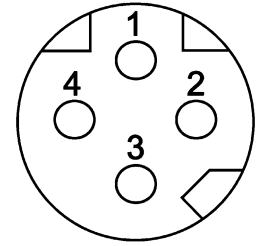

**Technical characteristics**

Number of contacts	4
Rated current	4 A
Rated voltage	60 V
Rated impulse voltage	1.5 kV
Pollution degree	3
Insulation resistance	>10 <sup>8</sup> Ω
Contact resistance	≤10 mΩ
Mating cycles	≥100
Degree of protection acc. to IEC 60529	IP67, when mated
Transmission characteristics	Cat. 5, Class D up to 100 MHz
Tightening torque	1 Nm Lock nut





**Technical characteristics**

Material (contacts)	Copper alloy
Surface (contacts)	Gold plated
RoHS	compliant with exemption

**Specifications and approvals**

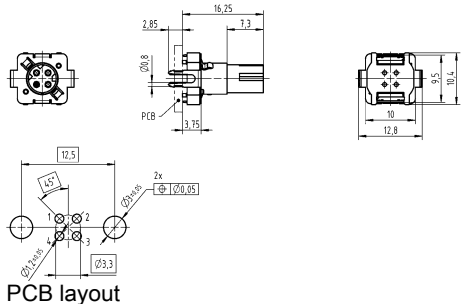
IEC 61076-2-114

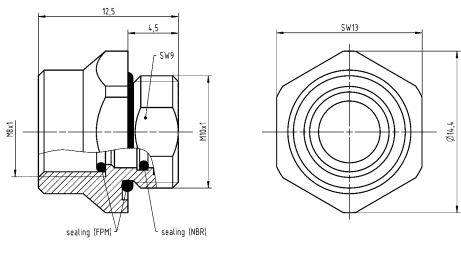

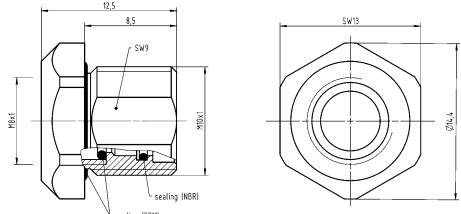
Identification	Part number Female	Drawing (dimensions in mm)
<p>Circular connectors M8, PCB connector, Straight, Wave soldering termination, Shielded</p>  <p>Order housings separately</p>	<p>21 42 000 0006</p>	 <p>PCB layout</p>
<p>Circular connectors M8, Housing, for front mounting, 9 mm</p> 	<p>21 41 000 0016</p>	
<p>Circular connectors M8, Housing, for front mounting, 13 mm</p> 	<p>21 41 000 0017</p>	

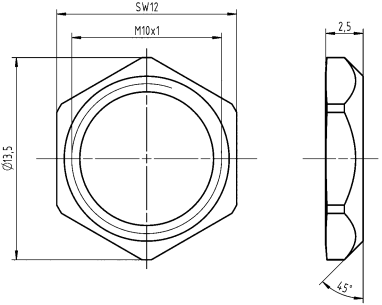
Identification	Part number Female	Drawing (dimensions in mm)
<p>M8</p> <p>Circular connectors M8, hexagonal nut, M10 x 1</p> 	<p>21 41 000 0018</p>	

Number of contacts

4

Wave soldering termination  
Shielded

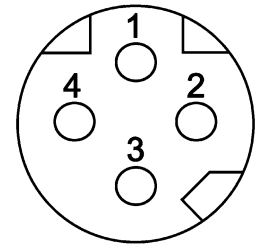

M8

Technical characteristics



Number of contacts	4
Rated current	4 A
Rated voltage	60 V
Rated impulse voltage	1.5 kV
Pollution degree	3
Insulation resistance	>10 <sup>8</sup> Ω
Contact resistance	≤10 mΩ
Mating cycles	≥100
Degree of protection acc. to IEC 60529	IP67, when mated

Technical characteristics



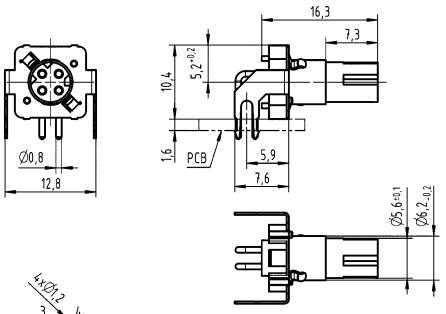
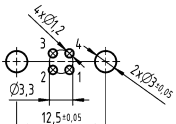

Transmission characteristics	Cat. 5, Class D up to 100 MHz
Tightening torque	1 Nm Lock nut
Material (contacts)	Copper alloy
Surface (contacts)	Gold plated
RoHS	compliant with exemption

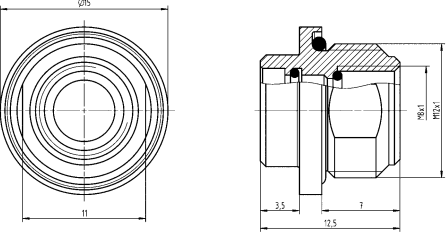
Specifications and approvals

IEC 61076-2-114

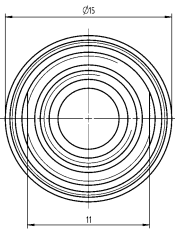
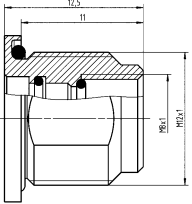
Identification	Part number Female	Drawing (dimensions in mm)
<p>Circular connectors M8, PCB connector, Angled, Wave soldering termination, Shielded</p>  <p>Order housings separately</p>	21 42 010 0003 401	 <p>PCB layout</p> 
<p>Circular connectors M8, Housing, for rear mounting, 7 mm</p> 	21 42 010 0004 401	

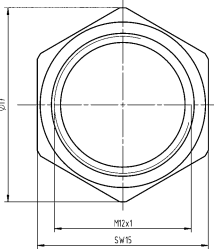
M8

Identification	Part number Female	Drawing (dimensions in mm)	
<p>Circular connectors M8, Housing, for rear mounting, 11 mm</p> 	<p>21 42 010 0002 401</p>		
<p>Circular connectors M8, hexagonal nut, M12 x 1</p> 	<p>21 42 010 0001 401</p>		

Number of contacts

4

Wave soldering termination  
Shielded

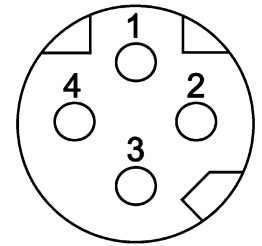

M8

### Technical characteristics

Number of contacts	4
Rated current	4 A
Rated voltage	60 V
Rated impulse voltage	1.5 kV
Pollution degree	3
Insulation resistance	>10 <sup>8</sup> Ω
Contact resistance	≤10 mΩ
Mating cycles	≥100
Degree of protection acc. to IEC 60529	IP67

### Technical characteristics

Transmission characteristics	Cat. 5, Class D up to 100 MHz
Tightening torque	1 Nm Lock nut
Material (contacts)	Copper alloy
Surface (contacts)	Gold plated
RoHS	compliant with exemption

### Specifications and approvals

IEC 61076-2-114

#### Identification

Circular connectors M8,  
9 mm,  
PCB connector,  
Straight,  
for front mounting,  
Wave soldering termination,  
Shielded



Part number  
Female

21 42 000 0014

Drawing  
(dimensions in mm)

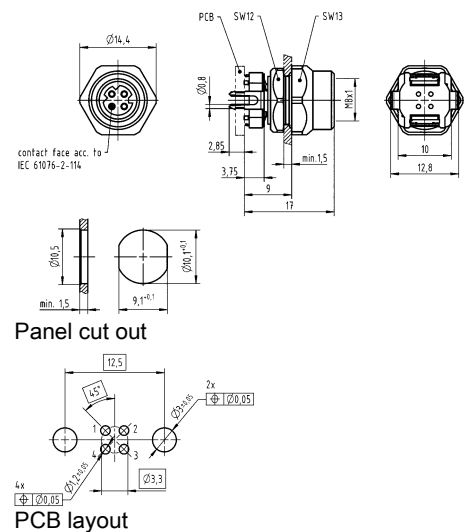

M8

Identification	Part number Female	Drawing (dimensions in mm)
----------------	-----------------------	-------------------------------

Circular connectors M8,  
13 mm,  
PCB connector,  
Straight,  
for front mounting,  
Wave soldering termination,  
Shielded



21 42 000 0005

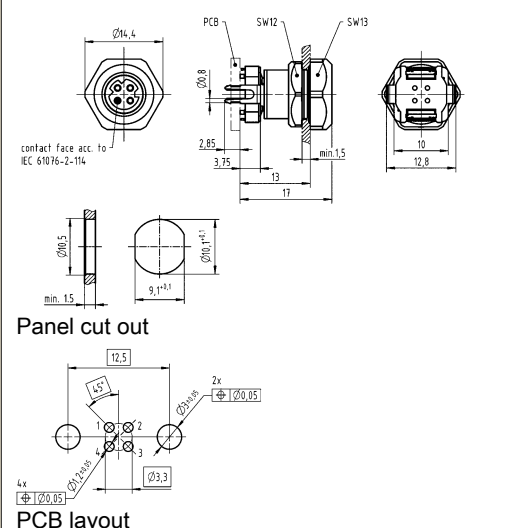

Circular connectors M8,  
7 mm,  
PCB connector,  
Angled,  
for rear mounting,  
Wave soldering termination,  
Shielded



21 42 000 0020

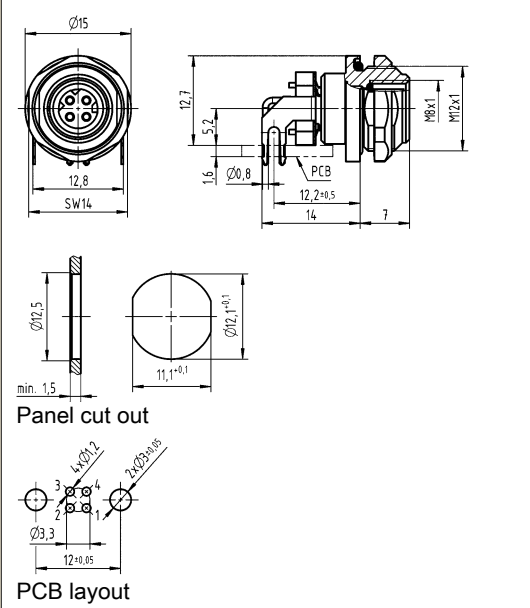

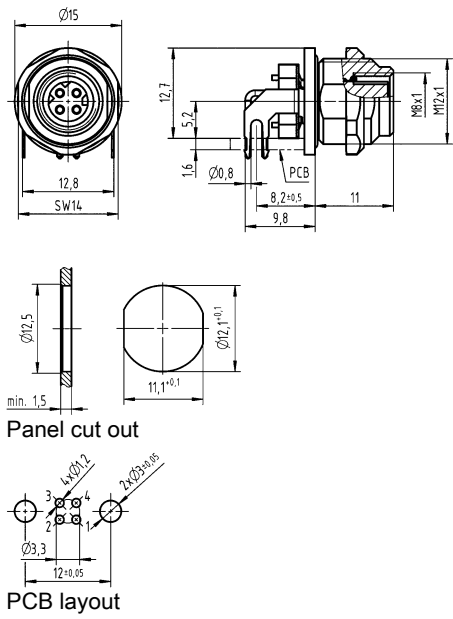
Identification	Part number Female	Drawing (dimensions in mm)
<p>Circular connectors M8, 11 mm, PCB connector, Angled, for rear mounting, Wave soldering termination, Shielded</p> 	<p>21 42 000 0019</p>	 <p>Panel cut out</p> <p>PCB layout</p>

M8

Number of contacts

4

Reflow soldering termination (THR)  
Shielded

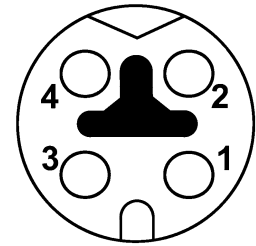

### Technical characteristics

Number of contacts	4
Rated current	4 A
Rated voltage	60 V
Rated impulse voltage	1.5 kV
Pollution degree	3
Insulation resistance	>10 <sup>8</sup> Ω
Contact resistance	≤10 mΩ
Mating cycles	≥100
Degree of protection acc. to IEC 60529	IP65 / IP67, when mated

### Technical characteristics

Transmission characteristics	Cat. 5, Class D up to 100 MHz
Tightening torque	1 Nm Lock nut
Material (contacts)	Copper alloy
Surface (contacts)	Gold plated
RoHS	compliant with exemption

### Specifications and approvals

IEC 61076-2-114

Identification

Part number  
Female

Drawing  
(dimensions in mm)

Circular connectors M8,  
PCB connector,  
Reflow soldering termination (THR),  
Shielded,  
Pack contents:  
50 pieces in a tray

21 02 341 2418



Order housings separately

Circular connectors M8,  
PCB connector,  
Straight,  
Reflow soldering termination (THR),  
Shielded,  
Pack contents:  
25 pieces in a carton box

21 02 341 2419



Order housings separately

Circular connectors M8,  
Housing,  
for front mounting,  
Pack contents:  
incl. lock nut

21 02 301 2001

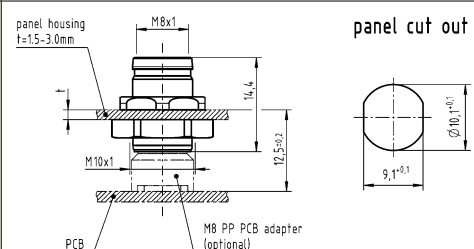
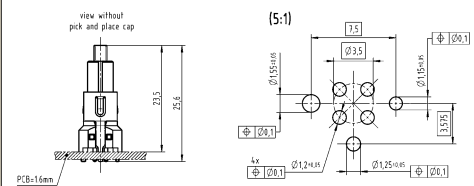



Identification	Part number Female	Drawing (dimensions in mm)
Circular connectors M8, Housing, for front mounting, Pack contents: without lock nut	21 02 301 2002	
Lock nut, M10 x 1	21 01 000 0051	

M8

Number of contacts

**4**

Reflow soldering termination (THR)  
Shielded

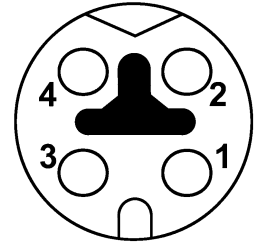

**Technical characteristics**

Number of contacts	4
Rated current	4 A
Rated voltage	60 V
Rated impulse voltage	1.5 kV
Pollution degree	3
Insulation resistance	>10 <sup>8</sup> Ω
Contact resistance	≤10 mΩ
Degree of protection acc. to IEC 60529	IP65 / IP67, when mated
Transmission characteristics	Cat. 5, Class D up to 100 MHz

**Technical characteristics**

Tightening torque	1 Nm Lock nut
Material (contacts)	Copper alloy
Surface (contacts)	Gold plated
RoHS	compliant with exemption

**Specifications and approvals**

IEC 61076-2-114

Identification	Part number Female	Drawing (dimensions in mm)
Circular connectors M8, PCB connector, Straight, for front mounting, Reflow soldering termination (THR), Shielded, Pack contents: incl. housing	21 02 341 2431	



M8

D03  
08  
·  
14

Number of contacts

# 3

Unshielded

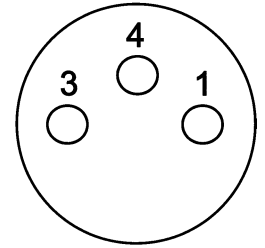

M8

## Technical characteristics

Number of contacts	3
Rated current	3 A
Rated voltage	50 V
Rated impulse voltage	1.5 kV
Pollution degree	3
Insulation resistance	>10 <sup>8</sup> Ω
Contact resistance	≤10 mΩ
Mating cycles	≥100
Locking type	Screw locking
Conductor length	50 cm
Degree of protection acc. to IEC 60529	IP67
Conductor cross-section	0.25 mm <sup>2</sup>
Conductor cross-section	AWG 24
Tightening torque	0.8 Nm Lock nut



## Technical characteristics

Material (insert)	Thermoplastic polyurethane (TPU)
Material (hood/housing)	Copper-zinc alloy
Material (contacts)	Brass
Surface (contacts)	Gold plated
RoHS	compliant with exemption, compliant

## Specifications and approvals

IEC 61076-2-104

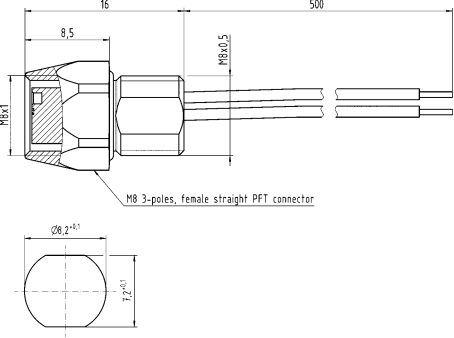

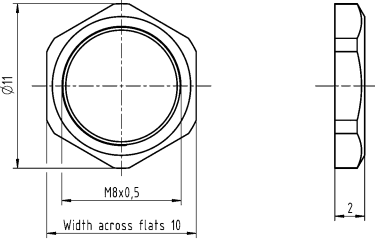
Identification	Conductor cross-section (mm <sup>2</sup> )	Part number Female	Drawing (dimensions in mm)
<p>Circular connectors M8, Panel feed through, With conductors, for front mounting, Unshielded</p> 	0.25	21 02 357 6305	 <p>M8 3-poles, female straight PFT connector</p> <p>Panel cut out</p>
<p>Circular connectors M8, hexagonal nut, M8 x 0.5</p> 		21 01 000 0048	

Number of contacts

# 4

Unshielded

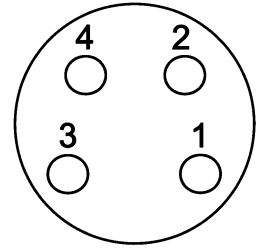

## Technical characteristics

Number of contacts	4
Rated current	3 A
Rated voltage	50 V
Rated impulse voltage	1.5 kV
Pollution degree	3
Insulation resistance	>10 <sup>8</sup> Ω
Contact resistance	≤10 mΩ
Mating cycles	≥100
Locking type	Screw locking
Conductor length	50 cm
Degree of protection acc. to IEC 60529	IP67
Conductor cross-section	0.25 mm <sup>2</sup>
Conductor cross-section	AWG 24
Tightening torque	0.8 Nm Lock nut



## Technical characteristics

Material (insert)	Thermoplastic polyurethane (TPU)
Material (hood/housing)	Copper-zinc alloy
Material (contacts)	Brass
Surface (contacts)	Gold plated
RoHS	compliant with exemption, compliant

## Specifications and approvals

IEC 61076-2-104

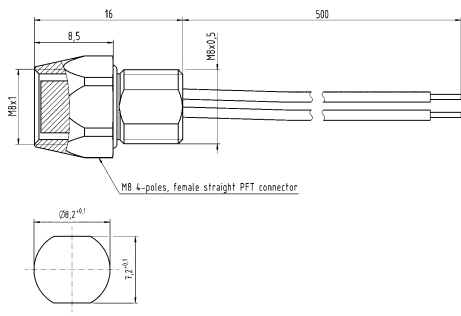

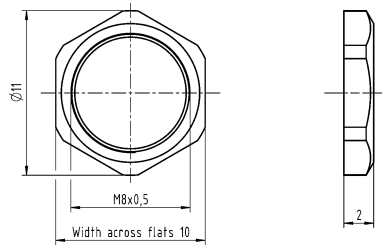
Identification	Conductor cross-section (mm <sup>2</sup> )	Part number Female	Drawing (dimensions in mm)
<p>Circular connectors M8, Panel feed through, With conductors, for front mounting, Unshielded</p> 	0.25	21 02 357 6405	 <p>M8 4-poles, female straight PFT connector</p> <p>Panel cut out</p>
<p>Circular connectors M8, hexagonal nut, M8 x 0.5</p> 		21 01 000 0048	



D03  
08  
·  
16

## Technical characteristics

Material (accessories) Thermoplastic

## Technical characteristics

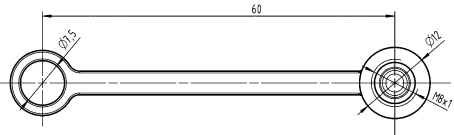
Colour (accessories) Black  
RoHS compliant

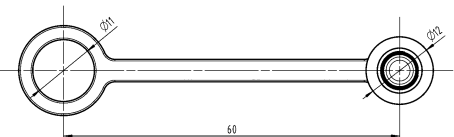
Identification	Part number	Drawing (dimensions in mm)
<p>Circular connectors M8, Cap, for male inserts, with cord</p> 	<p>21 41 000 0003</p>	
<p>Circular connectors M8, Cap, for female inserts, with cord</p> 	<p>21 41 000 0004</p>	

Contents

Page

PCB connectors.....	<b>D03 12.2</b>
PCB connectors with transformer.....	<b>D03 12.71</b>
Panel feed through .....	<b>D03 12.83</b>
Accessories .....	<b>D03 12.100</b>

Number of contacts

**4**

Reflow soldering termination (THR)  
Shielded

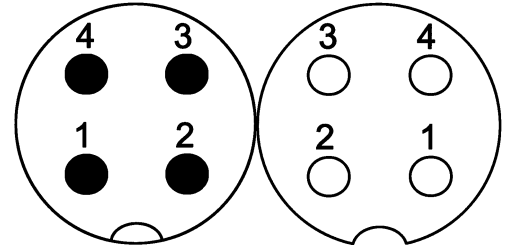

**Technical characteristics**

Number of contacts	4
Rated current	4 A
Rated voltage	250 V
Rated impulse voltage	1.5 kV
Pollution degree	3
Insulation resistance	>10 <sup>8</sup> Ω
Contact resistance	≤10 mΩ
Mating cycles	≥100
Locking type	Screw locking, PushPull
Degree of protection acc. to IEC 60529	IP65 / IP67, when mated
Tightening torque	2 Nm Lock nut





**Technical characteristics**

Material (insert)	Liquid crystal polymer (LCP)
Material (contacts)	Copper alloy
Surface (contacts)	Gold plated
RoHS	compliant with exemption, compliant

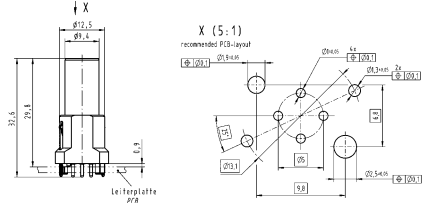
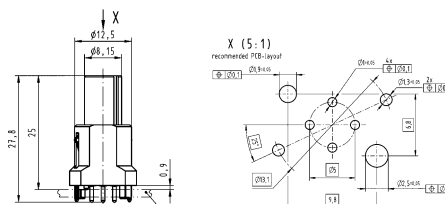
**Specifications and approvals**

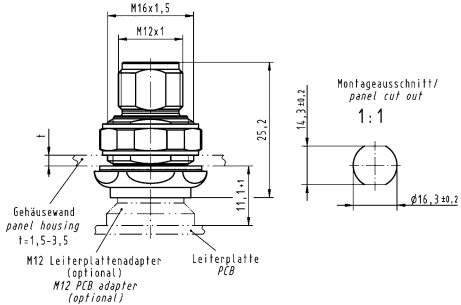
IEC 61076-2-101  
UL 1977 ECBT2.E102079  
CSA-C22.2 No. 182.3 ECBT8.E102079

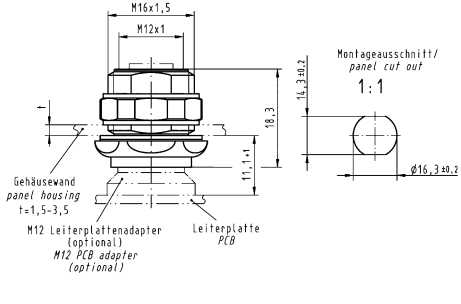
Identification	Part number		Drawing (dimensions in mm)
	Male	Female	
Circular connectors M12, PCB adapter, Straight, Reflow soldering termination (THR), Shielded, Pack contents: 60 pieces in a tray    Order housings separately	21 03 321 1418	21 03 321 2418	  

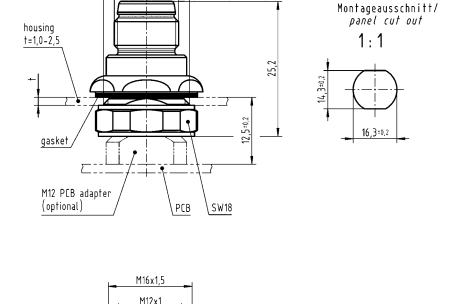
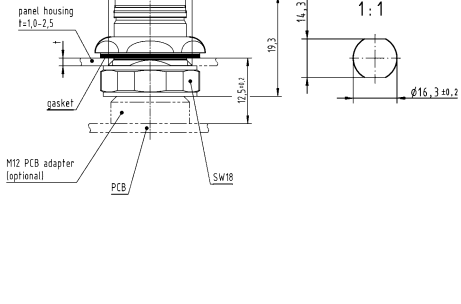
Identification	Part number		Drawing (dimensions in mm)
	Male	Female	
<p>Circular connectors M12, Housing, for rear mounting, Pack contents: 10 pieces</p> 	21 03 301 1000	21 03 301 2000	
<p>Circular connectors M12, PushPull, Housing, for front mounting, Pack contents: 10 pieces</p> 	21 03 301 1003	21 03 301 2003	
<p>Circular connectors M12, PushPull, Housing, for front mounting, Pack contents: 10 pieces</p> 	21 03 301 1003	21 03 301 2003	
			

M12

D03  
12  
-  
3

Number of contacts

**4**

Reflow soldering termination (THR)  
Shielded

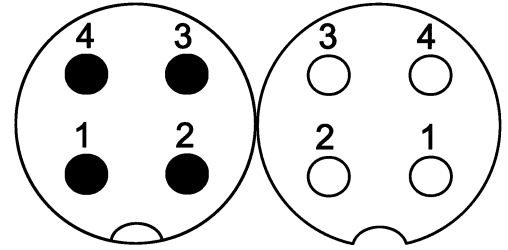

**Technical characteristics**

Number of contacts	4
Rated current	4 A
Rated voltage	250 V
Rated impulse voltage	1.5 kV
Pollution degree	3
Insulation resistance	>10 <sup>8</sup> Ω
Contact resistance	≤10 mΩ
Mating cycles	≥100
Locking type	Screw locking, PushPull
Degree of protection acc. to IEC 60529	IP65 / IP67, when mated
Tightening torque	2 Nm Lock nut

**Technical characteristics**

Material (insert)	Liquid crystal polymer (LCP)
Material (hood/housing)	Zinc die-cast
Material (contacts)	Copper alloy
Surface (contacts)	Gold plated
RoHS	compliant with exemption

**Specifications and approvals**

IEC 61076-2-101  
UL 1977 ECBT2.E102079  
CSA-C22.2 No. 182.3 ECBT8.E102079

Identification	Part number		Drawing (dimensions in mm)
	Male	Female	
Circular connectors M12, PCB adapter, Straight, incl. housing, for rear mounting, Reflow soldering termination (THR), Shielded	21 03 321 1430	21 03 321 2430	<p>Panel cut out</p> <p>Panel cut out</p>

D03  
12  
·  
4

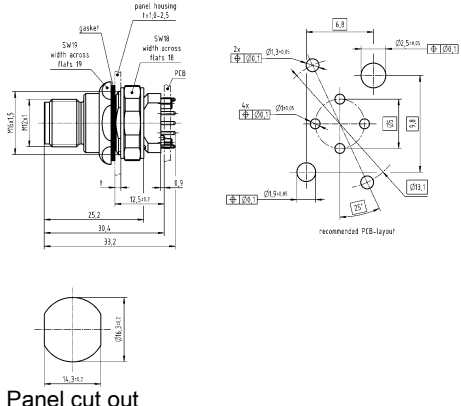
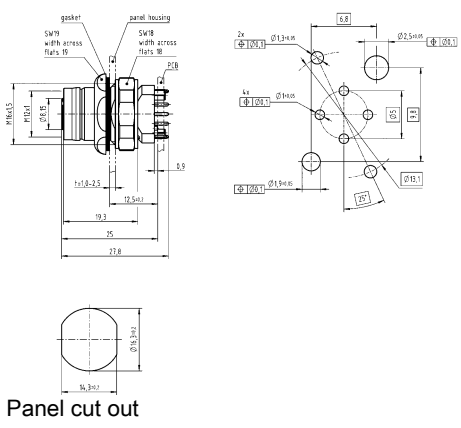
Identification	Part number		Drawing (dimensions in mm)
	Male	Female	
<p>Circular connectors M12, PushPull, PCB adapter, Straight, incl. housing, for front mounting, Reflow soldering termination (THR), Shielded</p> 	21 03 321 1431	21 03 321 2431	 <p>Panel cut out</p>  <p>Panel cut out</p>

M12

Number of contacts

**4**

Reflow soldering termination (THR)  
Shielded

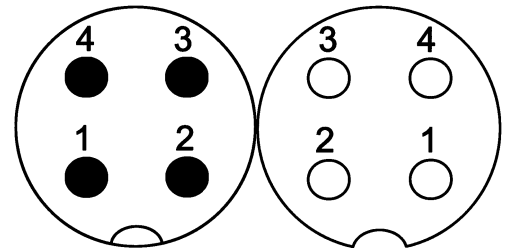

### Technical characteristics

Number of contacts	4
Rated current	4 A
Rated voltage	250 V
Rated impulse voltage	1.5 kV
Pollution degree	3
Insulation resistance	>10 <sup>8</sup> Ω
Contact resistance	≤10 mΩ
Mating cycles	≥100
Locking type	Screw locking
Degree of protection acc. to IEC 60529	IP20, IP67, when mated

### Technical characteristics

Tightening torque	2 Nm Lock nut
Material (insert)	Polyamide (PA)
Material (hood/housing)	Zinc die-cast
Material (contacts)	Copper alloy
Surface (contacts)	Gold plated
RoHS	compliant with exemption

### Specifications and approvals

IEC 61076-2-101

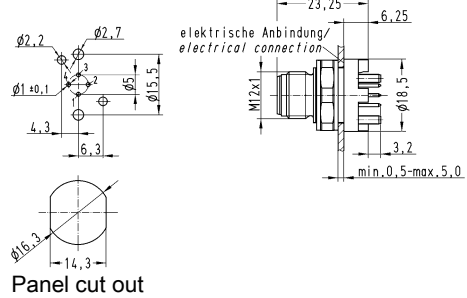
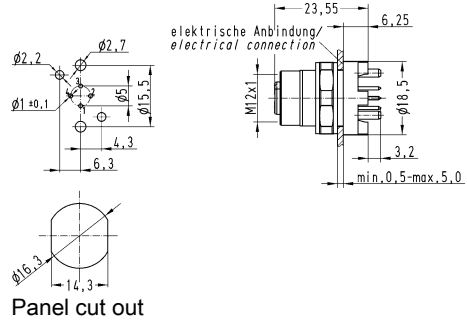
Identification	Part number		Drawing (dimensions in mm)
	Male	Female	
Circular connectors M12, PCB adapter, Straight, for rear mounting, Reflow soldering termination (THR), Shielded, IP20  	21 03 321 1410	21 03 321 6410	 <p>Panel cut out</p>  <p>Panel cut out</p>

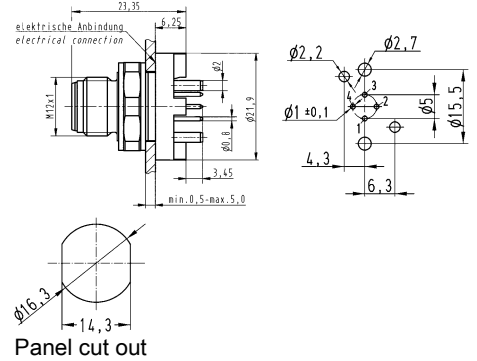
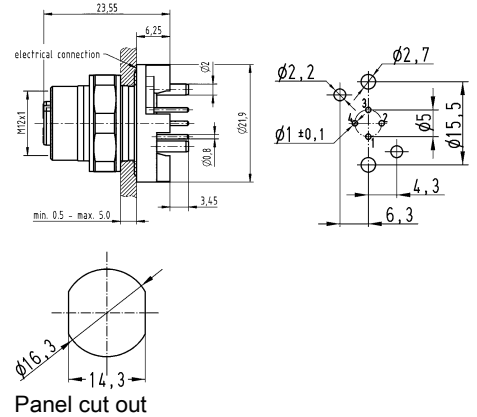
Identification	Part number		Drawing (dimensions in mm)
	Male	Female	
<p>Circular connectors M12, PCB adapter, Straight, for rear mounting, Reflow soldering termination (THR), Shielded, IP67</p> 	21 03 321 1420	21 03 321 6420	 <p>Panel cut out</p>  <p>Panel cut out</p>

M12

D03  
12  
·  
7

Number of contacts

**4**

Reflow soldering termination (SMT)  
Unshielded

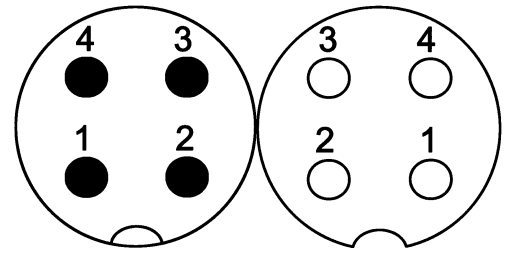

**Technical characteristics**



Number of contacts	4
Rated current	4 A
Rated voltage	250 V
Pollution degree	3
Insulation resistance	>10 <sup>8</sup> Ω
Contact resistance	≤10 mΩ
Mating cycles	≥100
Locking type	Screw locking
Degree of protection acc. to IEC 60529	IP67, when mated



**Technical characteristics**

Tightening torque	1 Nm Lock nut
Material (insert)	Liquid crystal polymer (LCP)
Material (contacts)	Copper alloy
Surface (contacts)	Gold plated
RoHS	compliant with exemption

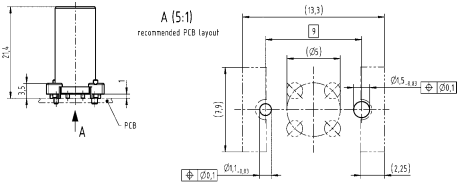
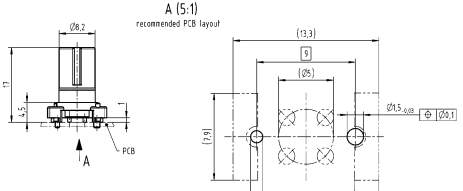
**Specifications and approvals**

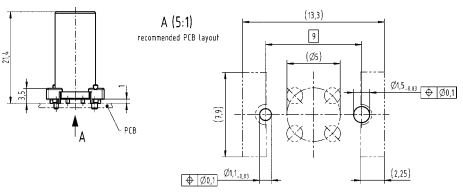
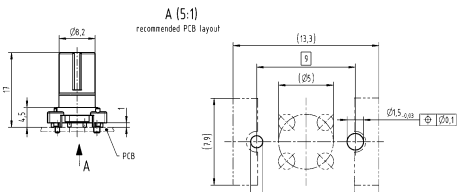
IEC 61076-2-101

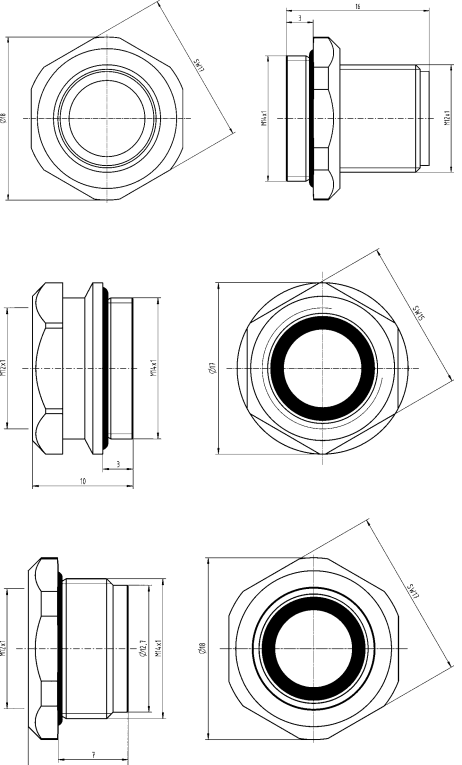
Identification	Part number		Drawing (dimensions in mm)
	Male	Female	
Circular connectors M12, PCB adapter, Straight, Reflow soldering termination (SMT), Unshielded    Order housings separately	21 03 311 1415	21 03 311 2410	  
Circular connectors M12, PCB adapter, Straight, Reflow soldering termination (SMT), Unshielded, Pack contents: 75 pieces on reel    Order housings separately	21 03 311 1416	21 03 311 2411	  

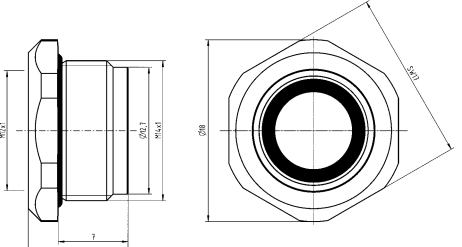
Identification	Part number		Drawing (dimensions in mm)
	Male	Female	
<p>Circular connectors M12, Housing, for front mounting, M14 x 1, 9 mm</p>  <p>If necessary, order lock nut 21 41 000 0011 separately.</p>	21 41 000 0012	21 41 000 0010	
<p>Circular connectors M12, Housing, for front mounting, M14 x 1, 13 mm</p>  <p>If necessary, order lock nut 21 41 000 0011 separately.</p>		21 41 000 0013	

Number of contacts

**4**

Wave soldering termination  
Shielded

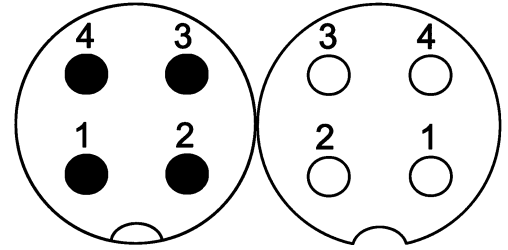

### Technical characteristics

Number of contacts	4
Rated current	4 A
Rated voltage	250 V
Pollution degree	3
Insulation resistance	>10 <sup>8</sup> Ω
Mating cycles	≥100
Locking type	Screw locking
Degree of protection acc. to IEC 60529	IP67, when screwed
Tightening torque	1 Nm Lock nut

### Technical characteristics

Material (insert)	Polyamide (PA)
Material (hood/housing)	Copper-zinc alloy
Material (contacts)	Copper alloy
Surface (contacts)	Gold plated
RoHS	compliant with exemption

### Specifications and approvals

IEC 61076-2-101

Identification	Part number		Drawing (dimensions in mm)
	Male	Female	
Circular connectors M12, PCB adapter, Angled, for rear mounting, Wave soldering termination, Shielded  	21 03 321 3401	21 03 321 4401	

Number of contacts

**5**

Reflow soldering termination (THR)  
Shielded

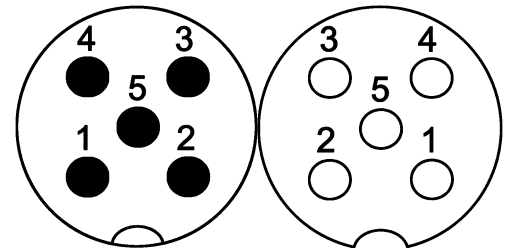

M12

**Technical characteristics**

Number of contacts	5
Rated current	4 A
Rated voltage	60 V
Rated impulse voltage	1.5 kV
Pollution degree	3
Insulation resistance	>10 <sup>8</sup> Ω
Contact resistance	≤10 mΩ
Mating cycles	≥100
Locking type	Screw locking, PushPull
Degree of protection acc. to IEC 60529	IP65 / IP67, when mated
Tightening torque	2 Nm Lock nut

**Technical characteristics**



Material (insert)	Liquid crystal polymer (LCP)
Material (contacts)	Copper alloy
Surface (contacts)	Gold plated
RoHS	compliant with exemption, compliant

**Specifications and approvals**

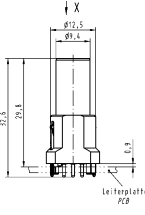
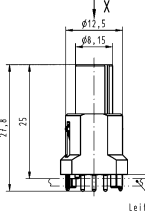
IEC 61076-2-101  
UL 1977 ECBT2.E102079  
CSA-C22.2 No. 182.3 ECBT8.E102079

Identification	Part number		Drawing (dimensions in mm)
	Male	Female	
Circular connectors M12, PCB adapter, Straight, Reflow soldering termination (THR), Shielded, Pack contents: 60 pieces in a tray    Order housings separately	21 03 321 1518	21 03 321 2518	 

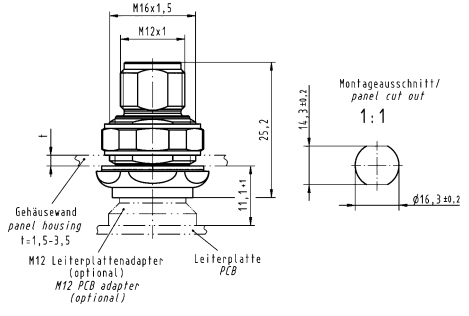
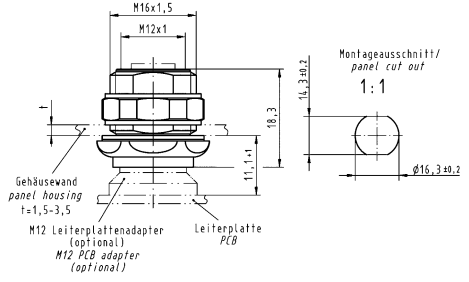
M12

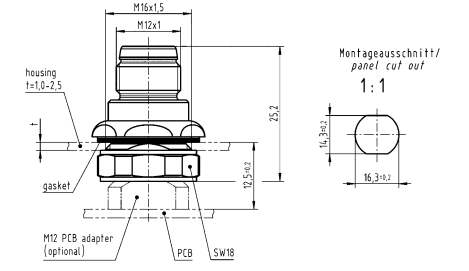
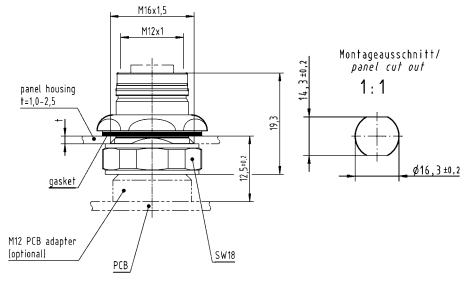
Identification	Part number		Drawing (dimensions in mm)
	Male	Female	
<p>Circular connectors M12, Housing, for rear mounting, Pack contents: 10 pieces</p> 	21 03 301 1000	21 03 301 2000	 
<p>Circular connectors M12, PushPull, Housing, for front mounting, Pack contents: 10 pieces</p> 	21 03 301 1003	21 03 301 2003	 

D03  
12  
-  
12

Number of contacts

**5**

Reflow soldering termination (THR)  
Shielded

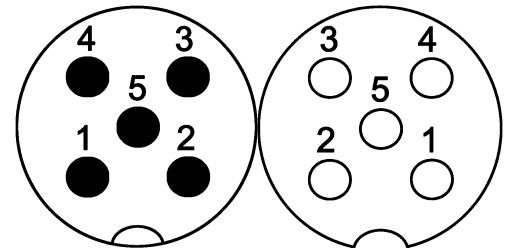

M12

**Technical characteristics**

Number of contacts	5
Rated current	4 A
Rated voltage	60 V
Rated impulse voltage	1.5 kV
Pollution degree	3
Insulation resistance	>10 <sup>8</sup> Ω
Contact resistance	≤10 mΩ
Mating cycles	≥100
Locking type	Screw locking, PushPull
Degree of protection acc. to IEC 60529	IP65 / IP67, when mated
Tightening torque	2 Nm Lock nut

**Technical characteristics**

Material (insert)	Liquid crystal polymer (LCP)
Material (hood/housing)	Zinc die-cast
Material (contacts)	Copper alloy
Surface (contacts)	Gold plated
RoHS	compliant with exemption

**Specifications and approvals**

IEC 61076-2-101  
UL 1977 ECBT2.E102079  
CSA-C22.2 No. 182.3 ECBT8.E102079

Identification	Part number		Drawing (dimensions in mm)
	Male	Female	
<p>Circular connectors M12, PCB adapter, Straight, incl. housing, for rear mounting, Reflow soldering termination (THR), Shielded</p>	21 03 321 1530	21 03 321 2530	<p>Panel cut out</p> <p>Panel cut out</p>

M12

Identification

Part number  
Male Female

Drawing  
(dimensions in mm)

Circular connectors M12, PushPull, PCB adapter, Straight, incl. housing, for front mounting, Reflow soldering termination (THR), Shielded



21 03 321 1531

21 03 321 2531

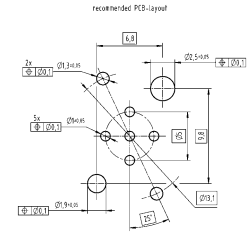
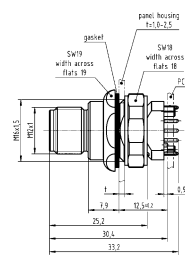

Panel cut out

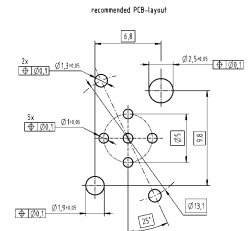
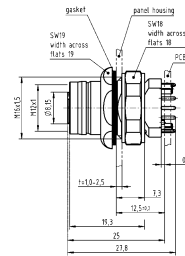

Panel cut out

D03  
12  
·  
14

Number of contacts

**5**

Reflow soldering termination (THR)  
Shielded

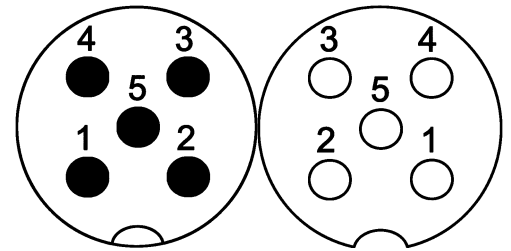

M12

### Technical characteristics

Number of contacts	5
Rated current	4 A
Rated voltage	60 V
Rated impulse voltage	1.5 kV
Pollution degree	3
Insulation resistance	>10 <sup>8</sup> Ω
Contact resistance	≤10 mΩ
Mating cycles	≥100
Locking type	Screw locking
Degree of protection acc. to IEC 60529	IP20, IP67, when mated

### Technical characteristics

Tightening torque	2 Nm Lock nut
Material (insert)	Polyamide (PA)
Material (hood/housing)	Zinc die-cast
Material (contacts)	Copper alloy
Surface (contacts)	Gold plated
RoHS	compliant with exemption

### Specifications and approvals

IEC 61076-2-101

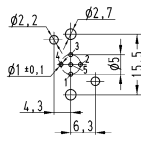
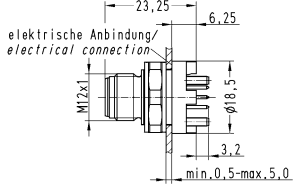
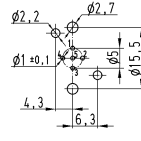
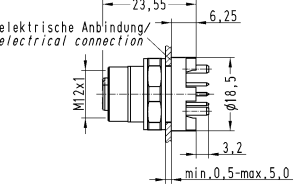
Identification	Part number		Drawing (dimensions in mm)
	Male	Female	
Circular connectors M12, PCB adapter, Straight, for rear mounting, Reflow soldering termination (THR), Shielded, IP20  	21 03 321 1510	21 03 321 6510	 <p>Panel cut out</p>  <p>elektrische Anbindung/ electrical connection</p>  <p>Panel cut out</p>  <p>elektrische Anbindung/ electrical connection</p>

Identification

Part number  
Male Female

Drawing  
(dimensions in mm)

M12

Circular connectors M12,  
PCB adapter,  
Straight,  
for rear mounting,  
Reflow soldering termination (THR),  
Shielded,  
IP67



21 03 321 1520

21 03 321 6520

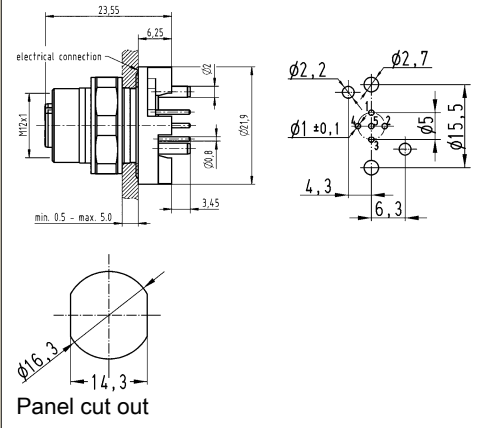
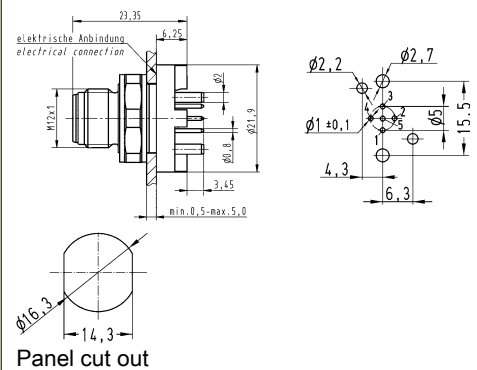

Number of contacts

5

Reflow soldering termination (SMT)  
Unshielded

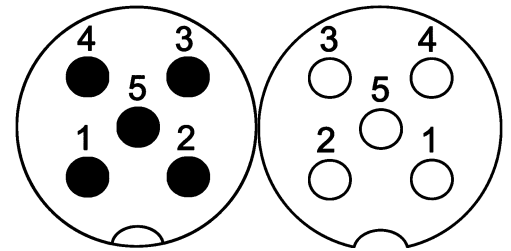

M12

Technical characteristics



Number of contacts	5
Rated current	4 A
Rated voltage	60 V
Pollution degree	3
Insulation resistance	>10 <sup>8</sup> Ω
Contact resistance	≤10 mΩ
Mating cycles	≥100
Locking type	Screw locking
Degree of protection acc. to IEC 60529	IP67, when mated

Technical characteristics

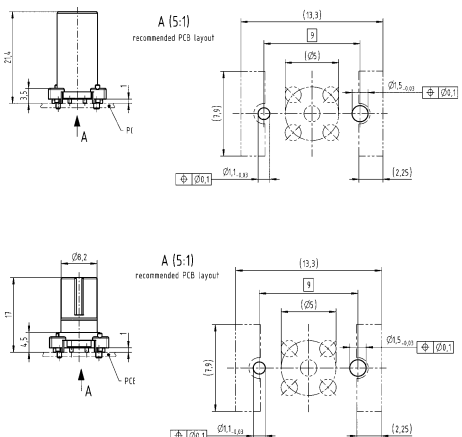

Tightening torque	1 Nm Lock nut
Material (insert)	Liquid crystal polymer (LCP)
Material (contacts)	Copper alloy
Surface (contacts)	Gold plated
RoHS	compliant with exemption

Specifications and approvals

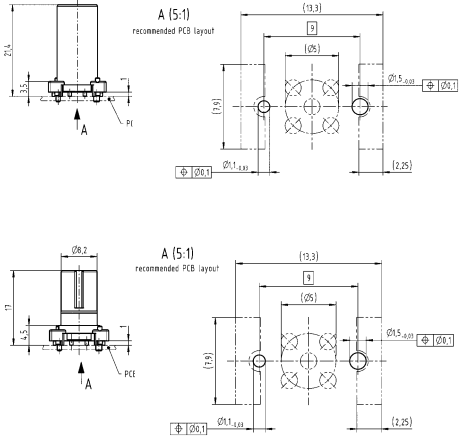
IEC 61076-2-101

Identification	Part number		Drawing (dimensions in mm)
	Male	Female	
Circular connectors M12, PCB adapter, Straight, Reflow soldering termination (SMT), Unshielded    Order housings separately	21 03 311 1515	21 03 311 2510	
Circular connectors M12, PCB adapter, Straight, Reflow soldering termination (SMT), Unshielded, Pack contents: 75 pieces on reel    Order housings separately	21 03 311 1516	21 03 311 2511	

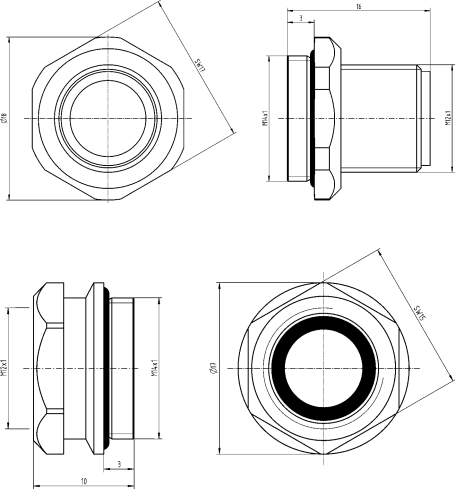
M12

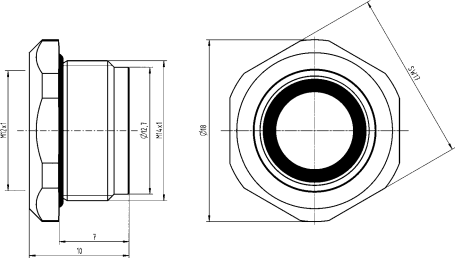
Identification	Part number		Drawing (dimensions in mm)
	Male	Female	
<p>Circular connectors M12, Housing, for front mounting, M14 x 1, 9 mm</p>  <p>If necessary, order lock nut 21 41 000 0011 separately.</p>	21 41 000 0012	21 41 000 0010	
<p>Circular connectors M12, Housing, for front mounting, M14 x 1, 13 mm</p>  <p>If necessary, order lock nut 21 41 000 0011 separately.</p>		21 41 000 0013	

Number of contacts

**5**

Wave soldering termination  
Shielded

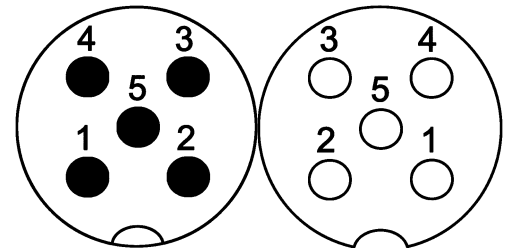

M12

### Technical characteristics

Number of contacts	5
Rated current	4 A
Rated voltage	60 V
Pollution degree	3
Insulation resistance	>10 <sup>8</sup> Ω
Mating cycles	≥100
Locking type	Screw locking
Degree of protection acc. to IEC 60529	IP67, when mated
Tightening torque	1 Nm Lock nut

### Technical characteristics

Material (insert)	Polyamide (PA)
Material (hood/housing)	Copper-zinc alloy
Material (contacts)	Copper alloy
Surface (contacts)	Gold plated
RoHS	compliant with exemption

### Specifications and approvals

IEC 61076-2-101

Identification	Part number		Drawing (dimensions in mm)
	Male	Female	
Circular connectors M12, PCB adapter, Angled, for rear mounting, Wave soldering termination, Shielded	21 03 321 3501	21 03 321 4501	



Number of contacts

8

Reflow soldering termination (THR)  
Shielded

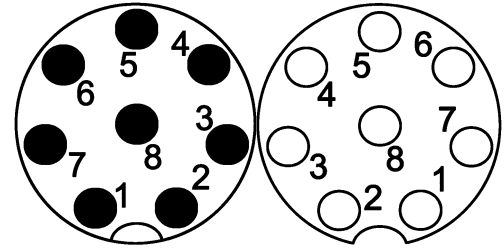

### Technical characteristics

Number of contacts	8
Rated current	2 A
Rated voltage	30 V
Rated impulse voltage	1.5 kV
Pollution degree	3
Insulation resistance	>10 <sup>8</sup> Ω
Contact resistance	≤10 mΩ
Mating cycles	≥100
Locking type	Screw locking, PushPull
Degree of protection acc. to IEC 60529	IP65 / IP67, when mated
Tightening torque	2 Nm Lock nut



### Technical characteristics

Material (insert)	Liquid crystal polymer (LCP)
Material (contacts)	Copper alloy
Surface (contacts)	Gold plated
RoHS	compliant with exemption, compliant

### Specifications and approvals

IEC 61076-2-101  
UL 1977 ECBT2.E102079  
CSA-C22.2 No. 182.3 ECBT8.E102079

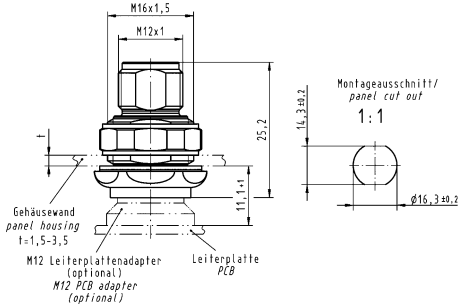
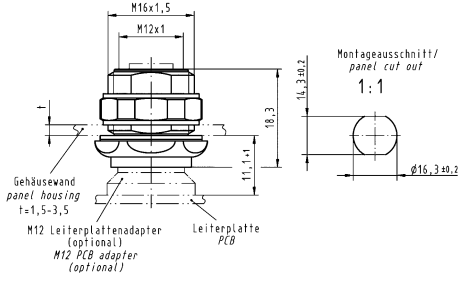
Identification	Part number		Drawing (dimensions in mm)
	Male	Female	
<p>Circular connectors M12, PCB adapter, Straight, Reflow soldering termination (THR), Shielded, Pack contents: 60 pieces in a tray</p>  <p>Order housings separately</p>	21 03 321 1818	21 03 321 2818	

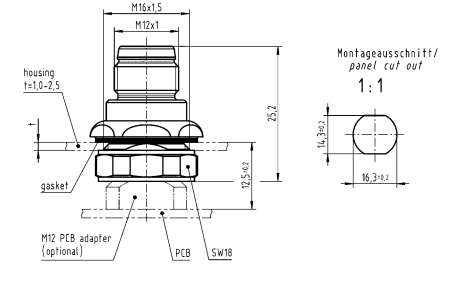
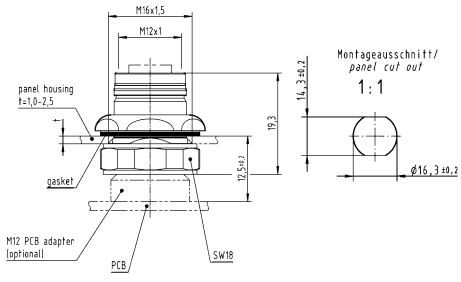
Identification	Part number		Drawing (dimensions in mm)
	Male	Female	
<p>Circular connectors M12, Housing, for rear mounting, Pack contents: 10 pieces</p> 	21 03 301 1000	21 03 301 2000	 
<p>Circular connectors M12, PushPull, Housing, for front mounting, Pack contents: 10 pieces</p> 	21 03 301 1003	21 03 301 2003	 

M12

D03  
12  
-  
21

Number of contacts

8

Reflow soldering termination (THR)  
Shielded

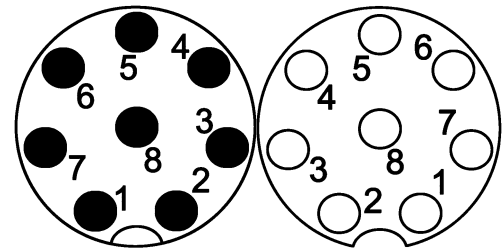

Technical characteristics

Number of contacts	8
Rated current	2 A
Rated voltage	30 V
Rated impulse voltage	1.5 kV
Pollution degree	3
Insulation resistance	>10 <sup>8</sup> Ω
Contact resistance	≤10 mΩ
Mating cycles	≥100
Locking type	Screw locking, PushPull
Degree of protection acc. to IEC 60529	IP65 / IP67, when mated
Tightening torque	2 Nm Lock nut

Technical characteristics

Material (insert)	Liquid crystal polymer (LCP)
Material (hood/housing)	Zinc die-cast
Material (contacts)	Copper alloy
Surface (contacts)	Gold plated
RoHS	compliant with exemption

Specifications and approvals

IEC 61076-2-101  
UL 1977 ECBT2.E102079  
CSA-C22.2 No. 182.3 ECBT8.E102079

Identification	Part number		Drawing (dimensions in mm)
	Male	Female	
Circular connectors M12, PCB adapter, Straight, incl. housing, for rear mounting, Reflow soldering termination (THR), Shielded	21 03 321 1830	21 03 321 2830	<p>Panel cut out</p> <p>Panel cut out</p>

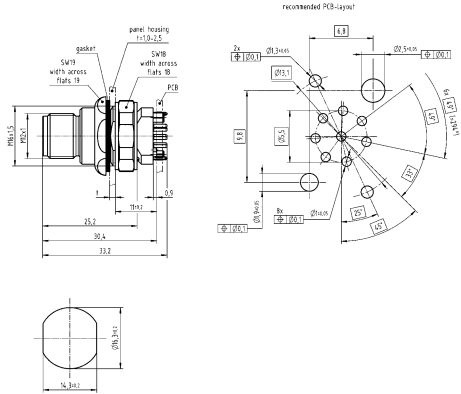
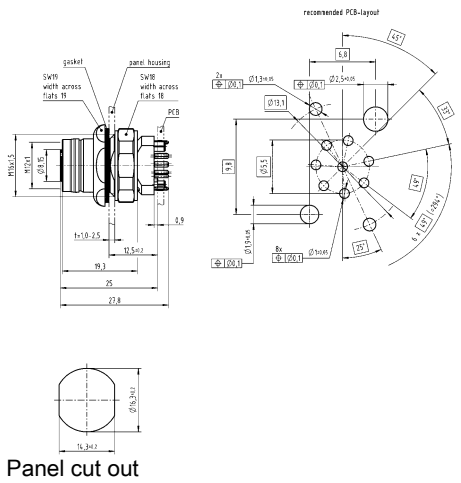

D03  
12  
-  
22

Identification	Part number		Drawing (dimensions in mm)
	Male	Female	
<p>Circular connectors M12, PushPull, PCB adapter, Straight, incl. housing, for front mounting, Reflow soldering termination (THR), Shielded</p> 	21 03 321 1831	21 03 321 2831	 <p>Panel cut out</p>  <p>Panel cut out</p>

M12

D03  
12  
-  
23

Number of contacts

8

Reflow soldering termination (SMT)  
Unshielded

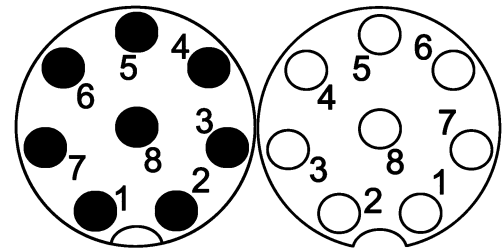

Technical characteristics







Number of contacts	8
Rated current	2 A
Rated voltage	30 V
Pollution degree	3
Insulation resistance	$>10^8 \Omega$
Contact resistance	$\leq 10 \text{ m}\Omega$
Mating cycles	$\geq 100$
Locking type	Screw locking
Degree of protection acc. to IEC 60529	IP67, when mated

Technical characteristics

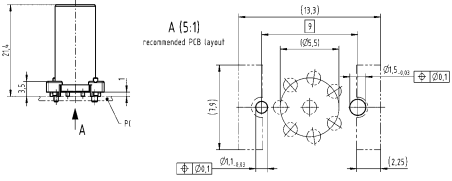

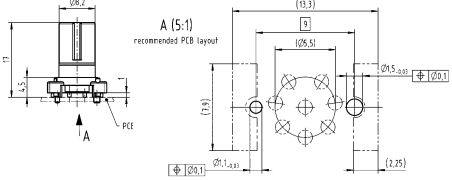
Tightening torque	1 Nm Lock nut
Material (insert)	Liquid crystal polymer (LCP)
Material (contacts)	Copper alloy
Surface (contacts)	Gold plated
RoHS	compliant with exemption

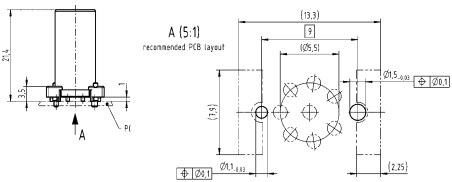
Specifications and approvals

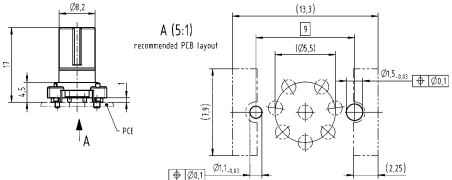
IEC 61076-2-101

Identification	Part number		Drawing (dimensions in mm)
	Male	Female	
Circular connectors M12, PCB adapter, Straight, Reflow soldering termination (SMT), Unshielded    Order housings separately	21 03 311 1815	21 03 311 2810	
Circular connectors M12, PCB adapter, Straight, Reflow soldering termination (SMT), Unshielded, Pack contents: 75 pieces on reel    Order housings separately	21 03 311 1816	21 03 311 2811	
Circular connectors M12, PCB adapter, Straight, Reflow soldering termination (SMT), Unshielded, Pack contents: 75 pieces on reel    Order housings separately	21 03 311 1816	21 03 311 2811	
Circular connectors M12, PCB adapter, Straight, Reflow soldering termination (SMT), Unshielded, Pack contents: 75 pieces on reel    Order housings separately	21 03 311 1816	21 03 311 2811	

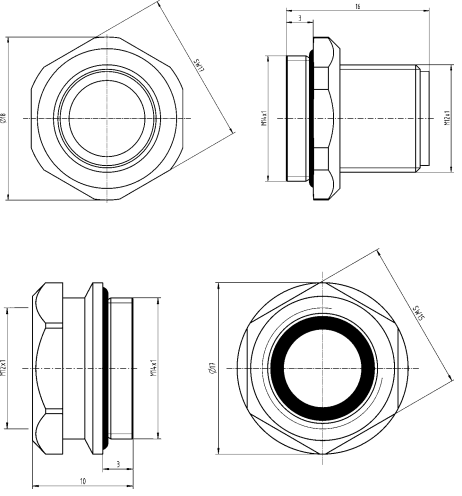
D03  
12  
·  
24

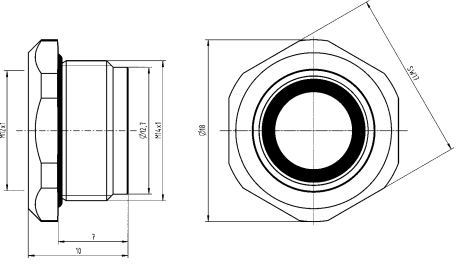
Identification	Part number		Drawing (dimensions in mm)
	Male	Female	
<p>Circular connectors M12, Housing, for front mounting, M14 x 1, 9 mm</p>  <p>If necessary, order lock nut 21 41 000 0011 separately.</p>	21 41 000 0012	21 41 000 0010	
<p>Circular connectors M12, Housing, for front mounting, M14 x 1, 13 mm</p>  <p>If necessary, order lock nut 21 41 000 0011 separately.</p>		21 41 000 0013	

M12

Number of contacts

8

Reflow soldering termination (SMT)  
Shielded

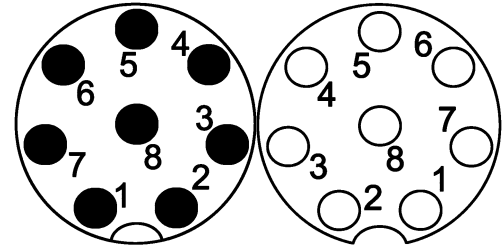

### Technical characteristics



Number of contacts	8
Rated current	2 A
Rated voltage	30 V
Pollution degree	3
Insulation resistance	$>10^8 \Omega$
Contact resistance	$\leq 10 \text{ m}\Omega$
Mating cycles	$\geq 100$
Locking type	Screw locking
Degree of protection acc. to IEC 60529	IP67, when mated



### Technical characteristics

Tightening torque	1 Nm Lock nut
Material (insert)	Liquid crystal polymer (LCP)
Material (contacts)	Copper alloy
Surface (contacts)	Gold plated
RoHS	compliant with exemption

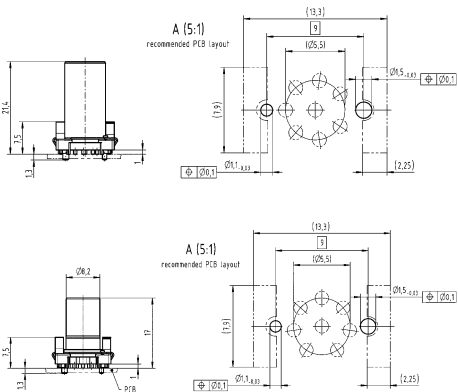
### Specifications and approvals

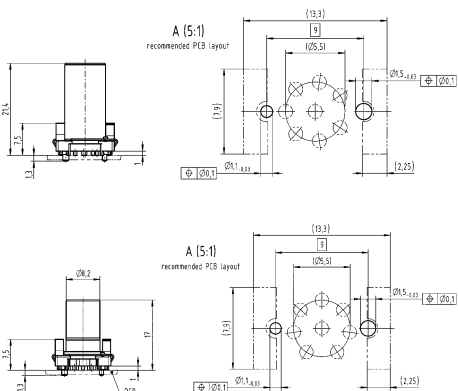
IEC 61076-2-101

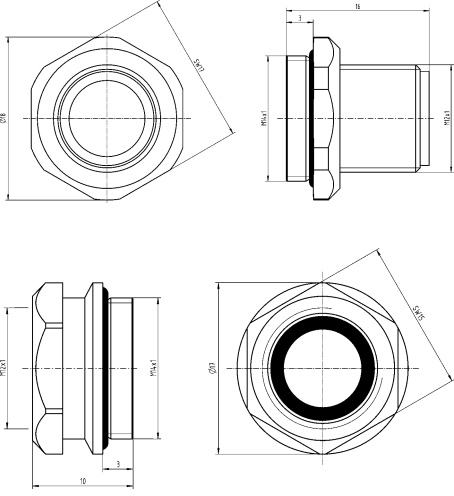
Identification	Part number		Drawing (dimensions in mm)
	Male	Female	
Circular connectors M12, PCB adapter, Straight, Reflow soldering termination (SMT), Shielded    Order housings separately	21 03 321 1802	21 03 321 2802	
Circular connectors M12, PCB adapter, Straight, Reflow soldering termination (SMT), Shielded, Pack contents: 75 pieces on reel    Order housings separately	21 03 321 1803	21 03 321 2803	

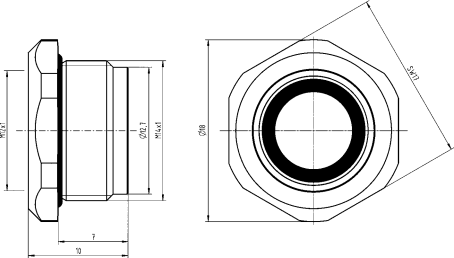
Identification	Part number		Drawing (dimensions in mm)
	Male	Female	
<p>Circular connectors M12, Housing, for front mounting, M14 x 1, 9 mm</p>  <p>If necessary, order lock nut 21 41 000 0011 separately.</p>	21 41 000 0012	21 41 000 0010	
<p>Circular connectors M12, Housing, for front mounting, M14 x 1, 13 mm</p>  <p>If necessary, order lock nut 21 41 000 0011 separately.</p>		21 41 000 0013	

M12

Number of contacts

**5**

Reflow soldering termination (THR)  
Shielded

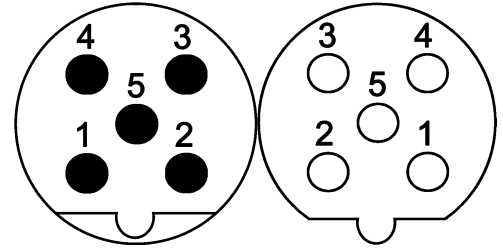

**Technical characteristics**

Number of contacts	5
Rated current	4 A
Rated voltage	50 V
Rated impulse voltage	1.5 kV
Pollution degree	3
Insulation resistance	>10 <sup>8</sup> Ω
Contact resistance	≤10 mΩ
Mating cycles	≥100
Locking type	Screw locking, PushPull
Degree of protection acc. to IEC 60529	IP65 / IP67, when mated
Tightening torque	2 Nm Lock nut



**Technical characteristics**

Material (insert)	Liquid crystal polymer (LCP)
Material (contacts)	Copper alloy
Surface (contacts)	Gold plated
RoHS	compliant with exemption, compliant

**Specifications and approvals**

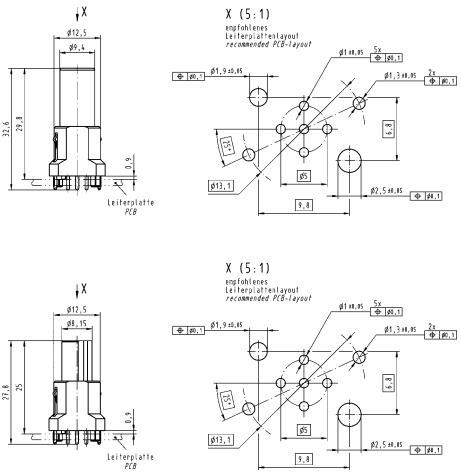
IEC 61076-2-101  
UL 1977 ECBT2.E102079  
CSA-C22.2 No. 182.3 ECBT8.E102079

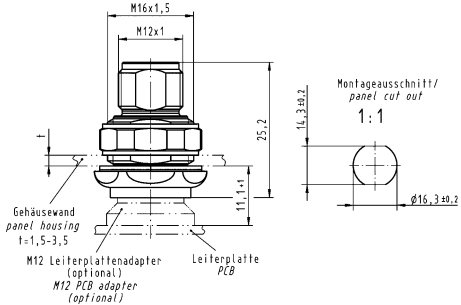
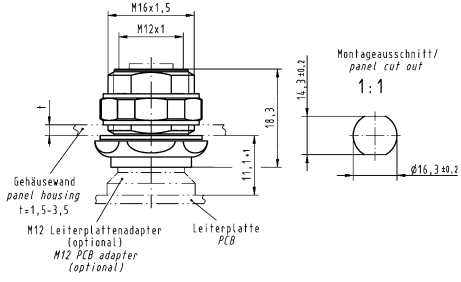
Identification	Part number		Drawing (dimensions in mm)
	Male	Female	
Circular connectors M12, PCB adapter, Straight, Reflow soldering termination (THR), Shielded, Pack contents: 60 pieces in a tray    Order housings separately	21 03 341 1518	21 03 341 2518	

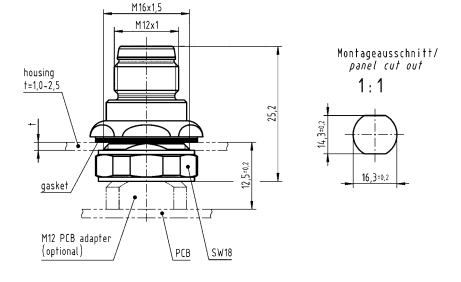
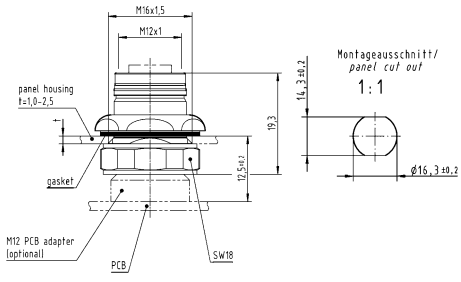
Identification	Part number		Drawing (dimensions in mm)
	Male	Female	
<p>Circular connectors M12, Housing, for rear mounting, Pack contents: 10 pieces</p> 	21 03 301 1000	21 03 301 2000	 
<p>Circular connectors M12, PushPull, Housing, for front mounting, Pack contents: 10 pieces</p> 	21 03 301 1003	21 03 301 2003	 

M12

D03  
12  
-  
29

Number of contacts

**5**

Reflow soldering termination (THR)  
Shielded

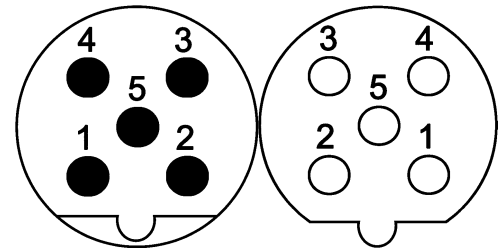

### Technical characteristics





Number of contacts	5
Rated current	4 A
Rated voltage	50 V
Rated impulse voltage	1.5 kV
Pollution degree	3
Insulation resistance	>10 <sup>8</sup> Ω
Contact resistance	≤10 mΩ
Mating cycles	≥100
Locking type	Screw locking
Degree of protection acc. to IEC 60529	IP65 / IP67, when mated
Tightening torque	2 Nm Lock nut

### Technical characteristics

Material (insert)	Liquid crystal polymer (LCP)
Material (hood/housing)	Zinc die-cast
Material (contacts)	Copper alloy
Surface (contacts)	Gold plated
RoHS	compliant with exemption

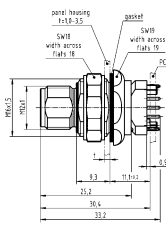
### Specifications and approvals

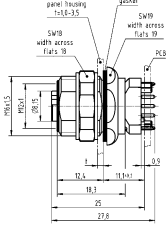
IEC 61076-2-101  
UL 1977 ECBT2.E102079  
CSA-C22.2 No. 182.3 ECBT8.E102079

Identification	Part number		Drawing (dimensions in mm)
	Male	Female	
Circular connectors M12, PCB adapter, Straight, incl. housing, for rear mounting, Reflow soldering termination (THR), Shielded  	21 03 341 1530	21 03 341 2530	  <p>Panel cut out</p>   <p>Panel cut out</p>

D03  
12  
·  
30

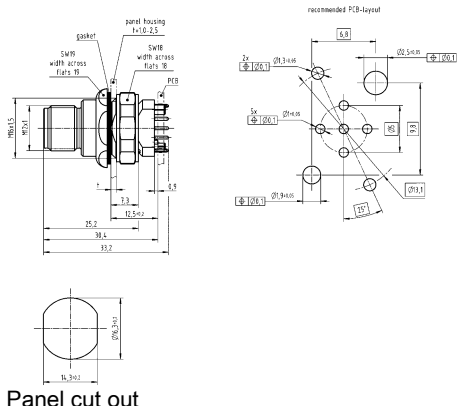
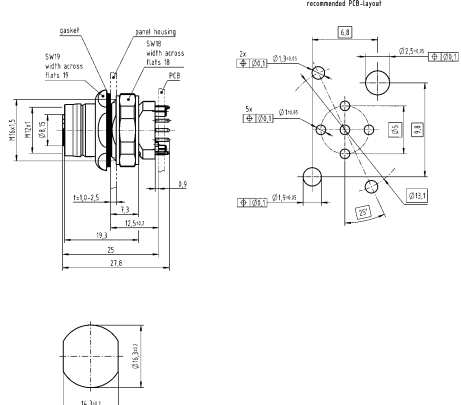
Identification	Part number		Drawing (dimensions in mm)
	Male	Female	
<p>Circular connectors M12, PCB adapter, Straight, incl. housing, for front mounting, Reflow soldering termination (THR), Shielded</p> 	21 03 341 1531	21 03 341 2531	 <p>Panel cut out</p>  <p>Panel cut out</p>

M12

Number of contacts

5

Reflow soldering termination (THR)  
Shielded

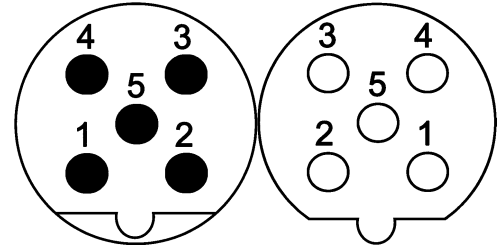

### Technical characteristics

Number of contacts	5
Rated current	4 A
Rated voltage	50 V
Rated impulse voltage	1.5 kV
Pollution degree	3
Insulation resistance	>10 <sup>8</sup> Ω
Contact resistance	≤10 mΩ
Mating cycles	≥100
Locking type	Screw locking
Degree of protection acc. to IEC 60529	IP67, when mated

### Technical characteristics

Tightening torque	2 Nm Lock nut
Material (insert)	Polyamide (PA)
Material (hood/housing)	Zinc die-cast
Material (contacts)	Copper alloy
Surface (contacts)	Gold plated
RoHS	compliant with exemption

### Specifications and approvals

IEC 61076-2-101

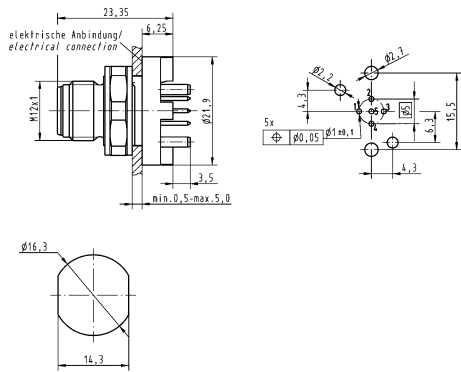
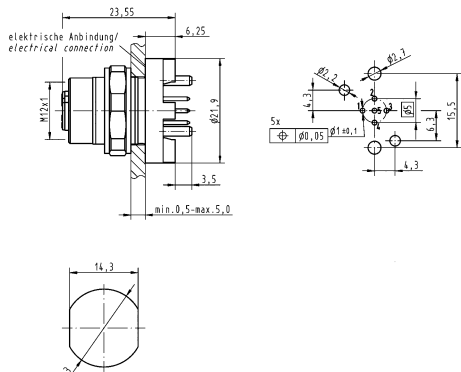
Identification	Part number		Drawing (dimensions in mm)
	Male	Female	
<p>Circular connectors M12, PCB adapter, Straight, Reflow soldering termination (THR), Shielded, IP67</p> 	21 03 341 1505	21 03 341 2505	 <p>Panel cut out</p>  <p>Panel cut out</p>

Number of contacts

4

Reflow soldering termination (THR)  
Shielded

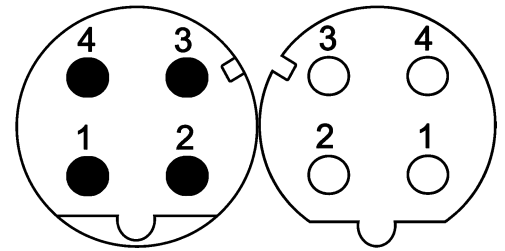

M12

Technical characteristics

Number of contacts	4
Rated current	4 A
Rated voltage	50 V
Rated impulse voltage	2.5 kV
Pollution degree	3
Insulation resistance	>10 <sup>8</sup> Ω
Contact resistance	≤10 mΩ
Mating cycles	≥100
Locking type	Screw locking, PushPull
Degree of protection acc. to IEC 60529	IP65 / IP67, when mated
Transmission characteristics	Cat. 5, Class D up to 100 MHz
Tightening torque	2 Nm Lock nut
Material (insert)	Liquid crystal polymer (LCP)

Technical characteristics

Material (contacts)	Copper alloy
Surface (contacts)	Gold plated
RoHS	compliant with exemption, compliant



Specifications and approvals

IEC 61076-2-101  
UL 1977 ECBT2.E102079  
CSA-C22.2 No. 182.3 ECBT8.E102079

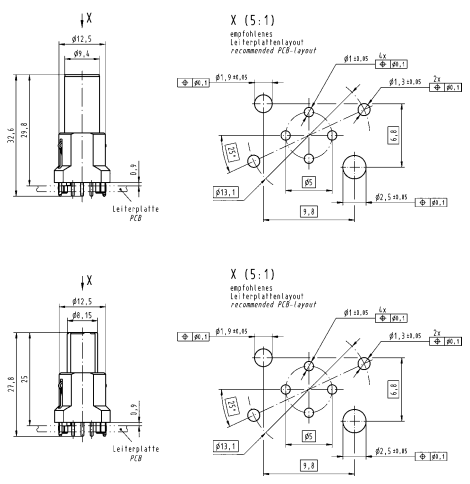

Identification	Part number		Drawing (dimensions in mm)
	Male	Female	
Circular connectors M12, PCB adapter, Straight, Reflow soldering termination (THR), Shielded, Pack contents: 60 pieces in a tray    Order housings separately	21 03 381 1418	21 03 381 2418	

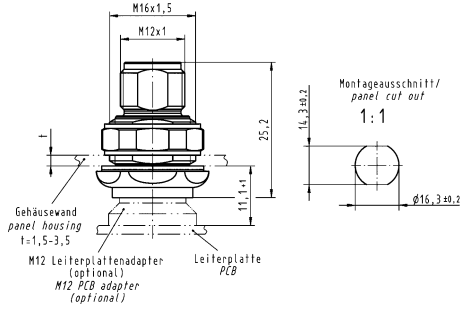
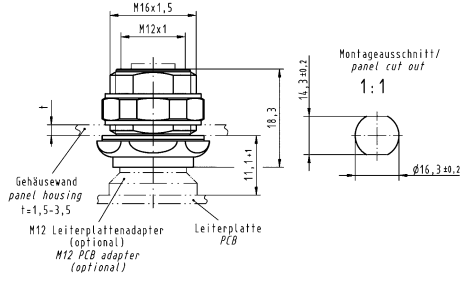
M12

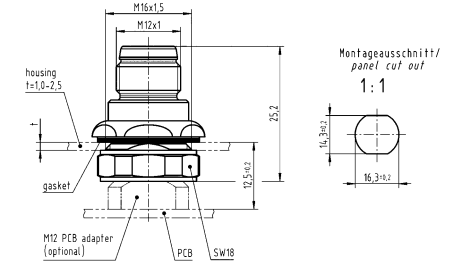
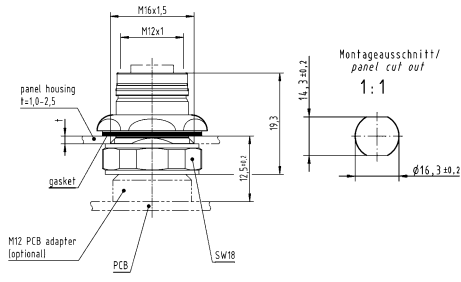
Identification	Part number		Drawing (dimensions in mm)
	Male	Female	
<p>Circular connectors M12, Housing, for rear mounting, Pack contents: 10 pieces</p> 	21 03 301 1000	21 03 301 2000	 
<p>Circular connectors M12, PushPull, Housing, for front mounting, Pack contents: 10 pieces</p> 	21 03 301 1003	21 03 301 2003	 

Number of contacts

4

Reflow soldering termination (THR)  
Shielded

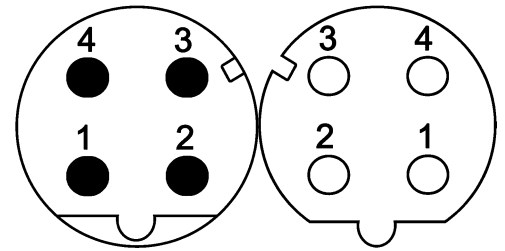

M12

Technical characteristics

Number of contacts	4
Rated current	4 A
Rated voltage	50 V
Rated impulse voltage	2.5 kV
Pollution degree	3
Insulation resistance	>10 <sup>8</sup> Ω
Contact resistance	≤10 mΩ
Mating cycles	≥100
Locking type	Screw locking, PushPull
Degree of protection acc. to IEC 60529	IP65 / IP67, when mated
Transmission characteristics	Cat. 5, Class D up to 100 MHz
Tightening torque	2 Nm Lock nut

Technical characteristics

Material (insert)	Liquid crystal polymer (LCP)
Material (hood/housing)	Zinc die-cast
Material (contacts)	Copper alloy
Surface (contacts)	Gold plated
RoHS	compliant with exemption

Specifications and approvals

IEC 61076-2-101  
UL 1977 ECBT2.E102079  
CSA-C22.2 No. 182.3 ECBT8.E102079

Identification	Part number		Drawing (dimensions in mm)
	Male	Female	
Circular connectors M12, PCB adapter, Straight, incl. housing, for rear mounting, Reflow soldering termination (THR), Shielded	21 03 381 1430	21 03 381 2430	<p>Panel cut out</p> <p>Panel cut out</p>



M12

Identification	Part number		Drawing (dimensions in mm)
	Male	Female	

Circular connectors M12, PushPull, PCB adapter, Straight, incl. housing, for front mounting, Reflow soldering termination (THR), Shielded



21 03 381 1431

21 03 381 2431

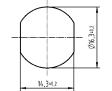
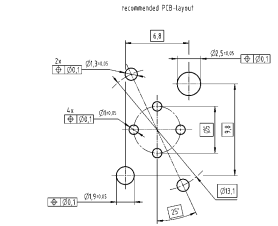
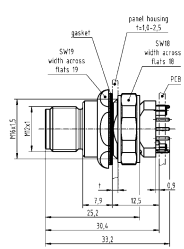

Panel cut out

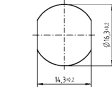
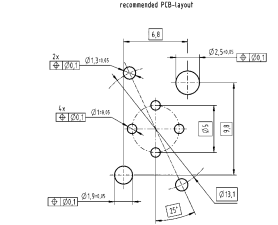
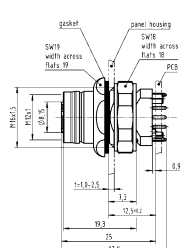

Panel cut out

Number of contacts

4

Reflow soldering termination (THR)  
Shielded

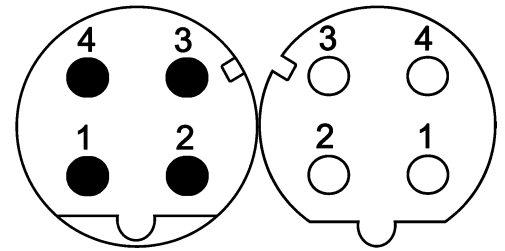

M12

Technical characteristics

Number of contacts	4
Rated current	4 A
Rated voltage	50 V
Rated impulse voltage	2.5 kV
Pollution degree	3
Insulation resistance	>10 <sup>8</sup> Ω
Contact resistance	≤10 mΩ
Mating cycles	≥100
Locking type	Screw locking
Degree of protection acc. to IEC 60529	IP67, when mated, IP20
Transmission characteristics	Cat. 5, Class D up to 100 MHz
Tightening torque	2 Nm Lock nut
Material (insert)	Polyamide (PA)

Technical characteristics

Material (hood/housing)	Zinc die-cast
Material (contacts)	Copper alloy
Surface (contacts)	Gold plated
RoHS	compliant with exemption



Specifications and approvals

IEC 61076-2-101  
UL 1977 ECBT2.E235076  
CSA-C22.2 No. 182.3 ECBT8.E235076

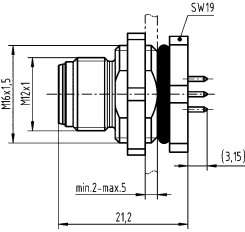
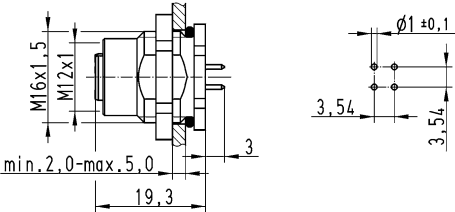
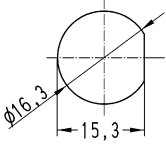
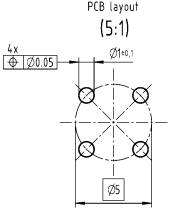

Identification	Part number		Drawing (dimensions in mm)
	Male	Female	
Circular connectors M12, PCB adapter, Straight, for rear mounting, Reflow soldering termination (THR), Shielded, IP67  	21 03 371 1400	21 03 371 2415	 <p>Panel cut out</p>  <p>Panel cut out</p>  <p>Panel cut out</p>  <p>PCB layout (5:1)</p>

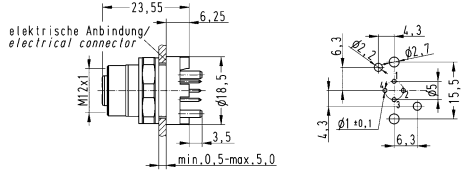
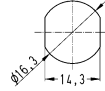
M12

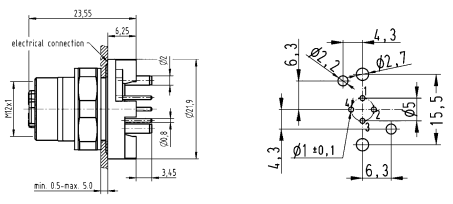
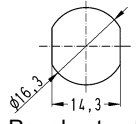
Identification	Part number		Drawing (dimensions in mm)
	Male	Female	
<p>Circular connectors M12, With fixing hole, PCB adapter, Straight, for rear mounting, Reflow soldering termination (THR), Shielded, IP20</p> 		21 03 381 6410	 <p>elektrische Anbindung/ electrical connector</p>  <p>Panel cut out</p>
<p>Circular connectors M12, With fixing hole, PCB adapter, Straight, for rear mounting, Reflow soldering termination (THR), Shielded, IP67</p> 		21 03 381 6420	 <p>electrical connection</p>  <p>Panel cut out</p>

Number of contacts

4

Reflow soldering termination (THR)  
Shielded

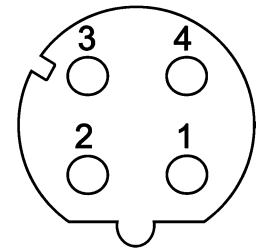

M12

Technical characteristics

Number of contacts	4
Rated current	4 A
Rated voltage	50 V
Rated impulse voltage	1.5 kV
Pollution degree	3
Insulation resistance	>10 <sup>8</sup> Ω
Contact resistance	≤10 mΩ
Mating cycles	≥100
Locking type	Screw locking
Degree of protection acc. to IEC 60529	IP20, IP67, when mated
Transmission characteristics	Cat. 5, Class D up to 100 MHz
Tightening torque	2 Nm Lock nut
Material (insert)	Liquid crystal polymer (LCP)

Technical characteristics

Material (hood/housing)	Zinc die-cast
Material (contacts)	Copper alloy
Surface (contacts)	Gold plated
RoHS	compliant with exemption

Specifications and approvals

IEC 61076-2-101  
UL 1977 ECBT2.E235076  
CSA-C22.2 No. 182.3 ECBT8.E235076



Identification

Part number  
Female

Drawing  
(dimensions in mm)

Circular connectors M12,  
PCB adapter,  
Angled,  
for rear mounting,  
Reflow soldering termination (THR),  
Shielded,  
IP20



Coding bottom left = Cable entry direction on the angled connector: to the right

21 03 381 4410

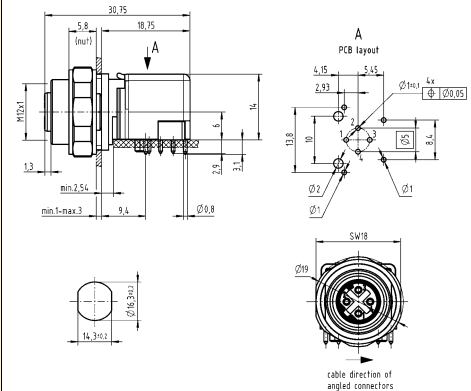

Panel cut out

Circular connectors M12,  
PCB adapter,  
Angled,  
for rear mounting,  
Reflow soldering termination (THR),  
Shielded,  
IP20





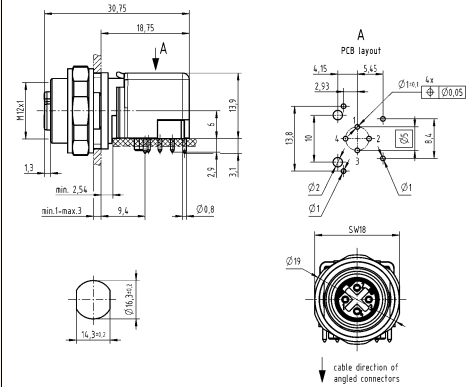

Coding top left = Cable entry direction on the angled connector: downwards

21 03 381 4411

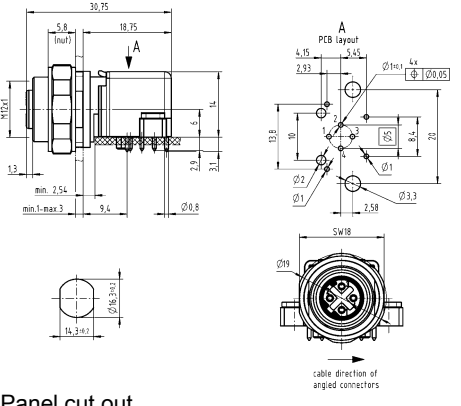

Panel cut out

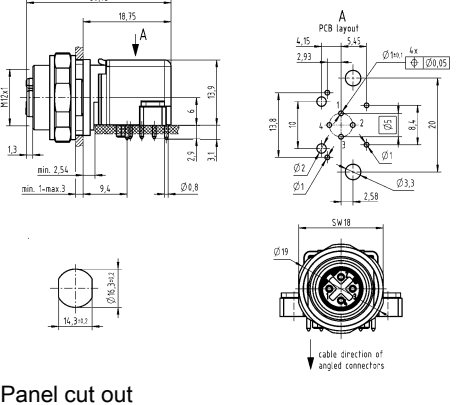
M12

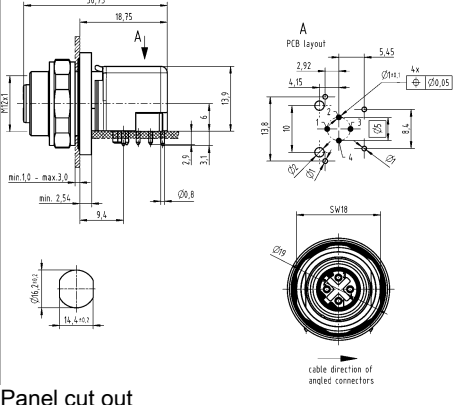
Identification	Part number Female	Drawing (dimensions in mm)
<p>Circular connectors M12, With fixing hole, PCB adapter, Angled, for rear mounting, Reflow soldering termination (THR), Shielded, IP20</p>  <p>Coding bottom left = Cable entry direction on the angled connector: to the right</p>	<p>21 03 381 4412</p>	 <p>Panel cut out</p>
<p>Circular connectors M12, With fixing hole, PCB adapter, Angled, for rear mounting, Reflow soldering termination (THR), Shielded, IP20</p>  <p>Coding top left = Cable entry direction on the angled connector: downwards</p>	<p>21 03 381 4413</p>	 <p>Panel cut out</p>
<p>Circular connectors M12, PCB adapter, Angled, for rear mounting, Reflow soldering termination (THR), Shielded, IP67</p>  <p>Coding bottom left = Cable entry direction on the angled connector: to the right</p>	<p>21 03 381 4430</p>	 <p>Panel cut out</p>

D03  
12  
·  
40

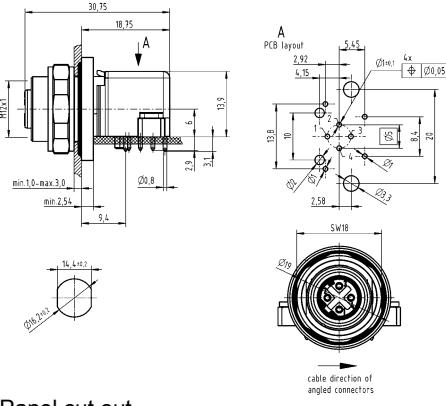
Identification	Part number Female	Drawing (dimensions in mm)
<p>Circular connectors M12, With fixing hole, PCB adapter, Angled, for rear mounting, Reflow soldering termination (THR), Shielded, IP67</p>  <p>Coding bottom left = Cable entry direction on the angled connector: to the right</p>	<p>21 03 381 4432</p>	 <p>Panel cut out</p>

M12

D03  
12  
·  
41

Number of contacts

**4**

Reflow soldering termination (THR)  
Shielded

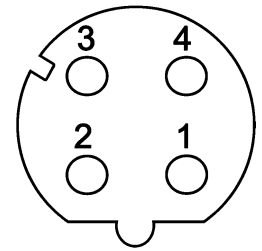

### Technical characteristics

Number of contacts	4
Rated current	4 A
Rated voltage	250 V
Rated impulse voltage	1.5 kV
Pollution degree	3
Insulation resistance	>10 <sup>8</sup> Ω
Contact resistance	≤10 mΩ
Mating cycles	≥100
Locking type	Screw locking, PushPull
Degree of protection acc. to IEC 60529	IP20, IP67, when mated
Transmission characteristics	Cat. 5, Class D up to 100 MHz
Tightening torque	2 Nm Lock nut

### Technical characteristics

Material (insert)	Liquid crystal polymer (LCP)
Material (hood/housing)	Zinc die-cast
Material (contacts)	Copper alloy
Surface (contacts)	Gold plated
RoHS	compliant with exemption

### Specifications and approvals

IEC 61076-2-101



Identification

Circular connectors M12,  
PushPull,  
PCB adapter,  
Angled,  
for rear mounting,  
Reflow soldering termination (THR),  
Shielded,  
IP20



Part number  
Female

21 03 381 4434

Drawing  
(dimensions in mm)

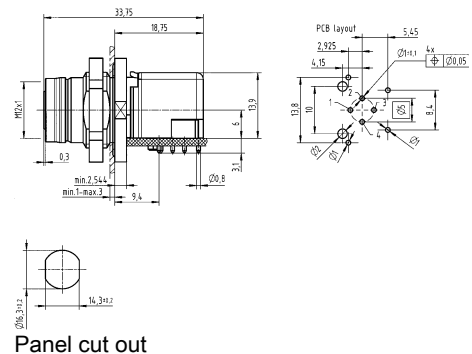



Circular connectors M12,  
PushPull,  
With fixing hole,  
PCB adapter,  
Angled,  
for rear mounting,  
Reflow soldering termination (THR),  
Shielded,  
IP20

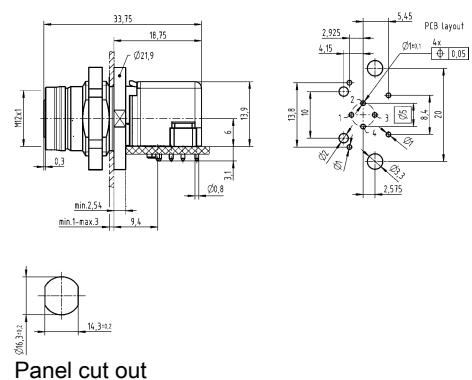

21 03 381 4435

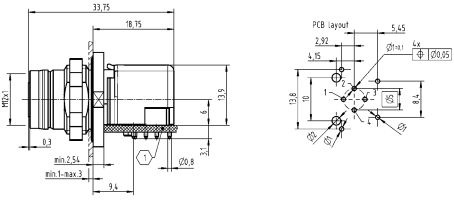

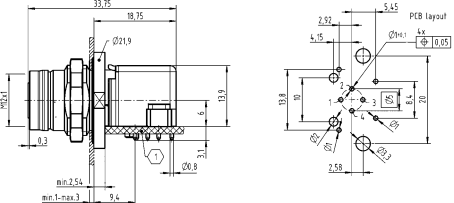
Identification	Part number Female	Drawing (dimensions in mm)
<p>Circular connectors M12, PushPull, PCB adapter, Angled, for rear mounting, Reflow soldering termination (THR), Shielded, IP67</p> 	<p>21 03 381 4436</p>	 <p>Panel cut out</p>
<p>Circular connectors M12, PushPull, With fixing hole, PCB adapter, Angled, for rear mounting, Reflow soldering termination (THR), Shielded, IP67</p> 	<p>21 03 381 4437</p>	 <p>Panel cut out</p>

M12

Number of contacts

**4**

Reflow soldering termination (SMT)  
Shielded

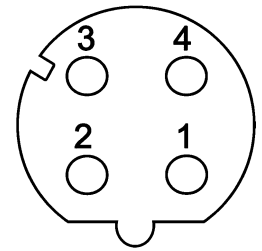

### Technical characteristics

Number of contacts	4
Rated current	4 A
Rated voltage	250 V
Pollution degree	3
Insulation resistance	>10 <sup>8</sup> Ω
Mating cycles	≥100
Locking type	Screw locking
Degree of protection acc. to IEC 60529	IP67, when mated
Transmission characteristics	Cat. 5, Class D up to 100 MHz

### Technical characteristics

Tightening torque	1 Nm Lock nut
Material (insert)	Liquid crystal polymer (LCP)
Material (contacts)	Copper alloy
Surface (contacts)	Gold plated
RoHS	compliant with exemption

### Specifications and approvals

IEC 61076-2-101

#### Identification

Circular connectors M12,  
PCB adapter,  
Straight,  
Reflow soldering termination (SMT),  
Shielded



Order housings separately

Circular connectors M12,  
PCB adapter,  
Straight,  
Reflow soldering termination (SMT),  
Shielded,

Pack contents:  
75 pieces on reel



Order housings separately

Circular connectors M12,  
Housing,  
for front mounting,  
M14 x 1,  
9 mm



If necessary, order lock nut 21 41 000 0011 separately.

#### Part number Female

21 03 381 2404

21 03 381 2405

21 41 000 0010

#### Drawing (dimensions in mm)

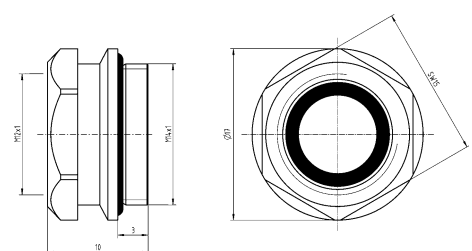
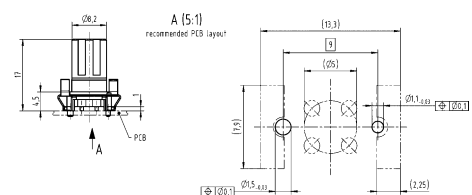
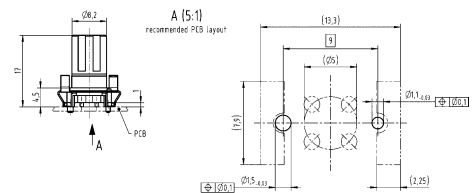

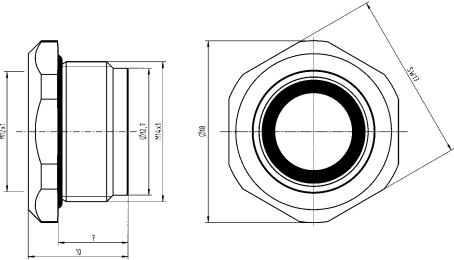
Identification	Part number Female	Drawing (dimensions in mm)
<p>Circular connectors M12, Housing, for front mounting, M14 x 1, 13 mm</p>  <p>If necessary, order lock nut 21 41 000 0011 separately.</p>	<p>21 41 000 0013</p>	

M12

Number of contacts

**4**

Wave soldering termination  
Shielded

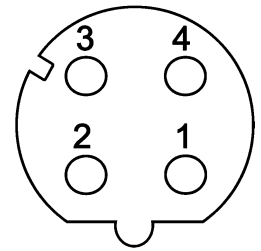

**Technical characteristics**

Number of contacts	4
Rated current	4 A
Rated voltage	250 V
Pollution degree	3
Insulation resistance	>10 <sup>8</sup> Ω
Mating cycles	≥100
Locking type	Screw locking
Degree of protection acc. to IEC 60529	IP67, when mated
Transmission characteristics	Cat. 5, Class D up to 100 MHz
Tightening torque	1 Nm Lock nut

**Technical characteristics**

Material (insert)	Polyamide (PA)
Material (hood/housing)	Copper-zinc alloy
Material (contacts)	Copper alloy
Surface (contacts)	Gold plated
RoHS	compliant with exemption

**Specifications and approvals**

IEC 61076-2-101

Identification

Circular connectors M12,  
PCB adapter,  
Angled,  
for rear mounting,  
Wave soldering termination,  
Shielded



Part number  
Female

21 03 381 4440

Drawing  
(dimensions in mm)

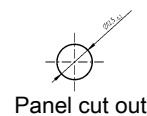
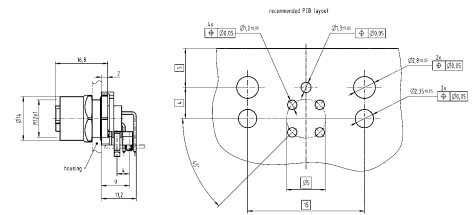

Panel cut out

Number of contacts

8

Reflow soldering termination (THR)  
Shielded

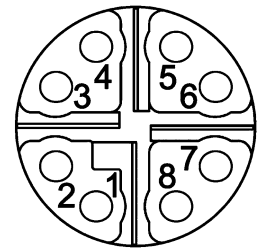

M12

Technical characteristics

Number of contacts	8
Rated current	0.5 A
Rated voltage	50 V
Rated impulse voltage	0.8 kV
Pollution degree	3
Insulation resistance	>10 <sup>8</sup> Ω
Contact resistance	≤10 mΩ
Mating cycles	≥100
Locking type	Screw locking, PushPull
Degree of protection acc. to IEC 60529	IP65 / IP67, when mated
Transmission characteristics	Cat. 6 <sub>A</sub> , Class E <sub>A</sub> up to 500 MHz, Cat. 5, Class D up to 100 MHz
Tightening torque	2 Nm Lock nut
Material (insert)	Liquid crystal polymer (LCP)

Technical characteristics

Material (contacts)	Copper alloy
Surface (contacts)	Gold plated
RoHS	compliant with exemption, compliant

Specifications and approvals

IEC 61076-2-109  
UL 1977 ECBT2.E102079  
CSA-C22.2 No. 182.3 ECBT8.E102079



Identification		Part number Female	Drawing (dimensions in mm)
<p>Circular connectors M12, PCB adapter, Straight, Reflow soldering termination (THR), Shielded, Pack contents: 60 pieces in a tray</p> <p>Order housings separately</p>	<p>Cat. 5 Cat. 6<sub>A</sub></p>	<p>21 03 381 2807 21 03 381 2806</p>	
<p>Circular connectors M12, PCB adapter, Angled, Reflow soldering termination (THR), Shielded, Pack contents: 30 pieces in a tray</p> <p>Order housings separately</p>	<p>Cat. 6<sub>A</sub></p>	<p>21 03 381 4806</p>	

M12

Identification

Part number  
Female

Drawing  
(dimensions in mm)

Circular connectors M12,  
Housing,  
for rear mounting,  
Pack contents:  
10 pieces



21 03 301 2000

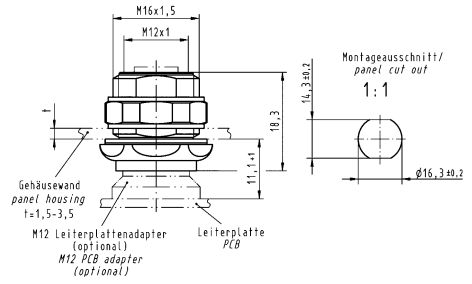

Circular connectors M12,  
PushPull,  
Housing,  
for front mounting,  
Pack contents:  
10 pieces



21 03 301 2003

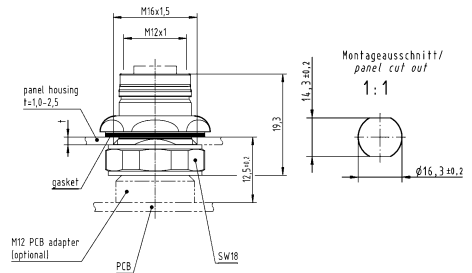

Number of contacts

8

Reflow soldering termination (THR)  
Shielded

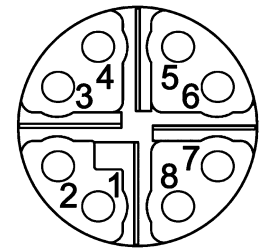

M12

### Technical characteristics

Number of contacts	8
Rated current	0.5 A
Rated voltage	50 V
Rated impulse voltage	0.8 kV
Pollution degree	3
Insulation resistance	>10 <sup>8</sup> Ω
Contact resistance	≤10 mΩ
Mating cycles	≥100
Locking type	Screw locking, PushPull
Degree of protection acc. to IEC 60529	IP65 / IP67, when mated
Transmission characteristics	Cat. 6A, Class EA up to 500 MHz, Cat. 5, Class D up to 100 MHz
Tightening torque	2 Nm Lock nut
Material (insert)	Liquid crystal polymer (LCP)

### Technical characteristics

Material (hood/housing)	Zinc die-cast
Material (contacts)	Copper alloy
Surface (contacts)	Gold plated
RoHS	compliant with exemption

### Specifications and approvals

IEC 61076-2-109  
UL 1977 ECBT2.E102079  
CSA-C22.2 No. 182.3 ECBT8.E102079



Identification	Part number	Drawing
	Female	(dimensions in mm)
<p>Circular connectors M12, PushPull, PCB adapter, Straight, incl. housing, for front mounting, Reflow soldering termination (THR), Shielded, Pack contents: 60 pieces in a tray</p>	<p>Cat. 5 Cat. 6A</p> <p>21 03 381 2803 21 03 381 2802</p>	<p>Panel cut out</p> <p>Panel cut out</p>

M12

Identification

Circular connectors M12, PushPull, PCB adapter, Straight, incl. housing, for front mounting, Reflow soldering termination (THR), Shielded



Cat. 5  
Cat. 6A

Part number  
Female

21 03 381 2814  
21 03 381 2813

Drawing  
(dimensions in mm)

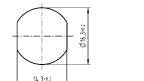
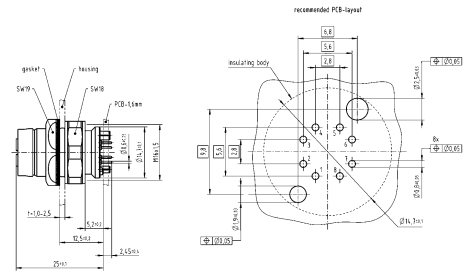

Panel cut out

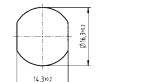
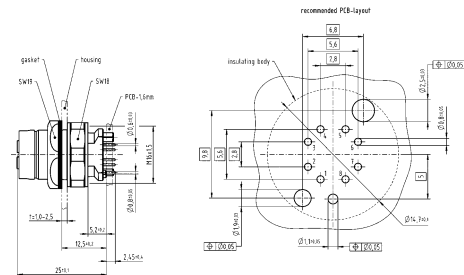

Panel cut out

Circular connectors M12, PCB adapter, Straight, incl. housing, for rear mounting, Reflow soldering termination (THR), Shielded,



Pack contents:  
60 pieces in a tray

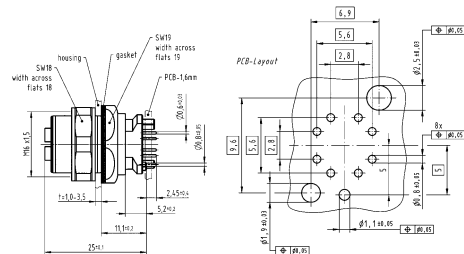
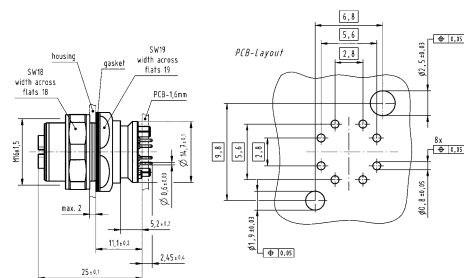

Cat. 5  
Cat. 6A

21 03 381 2809  
21 03 381 2810

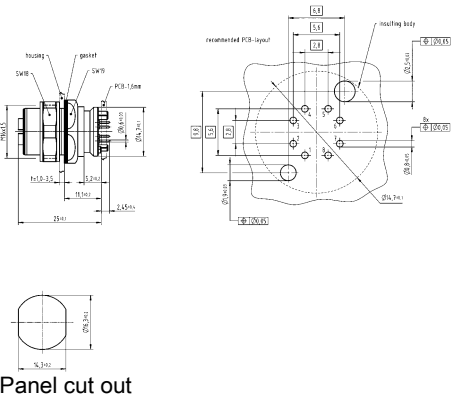
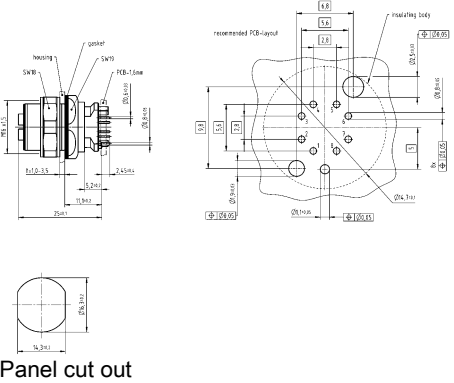

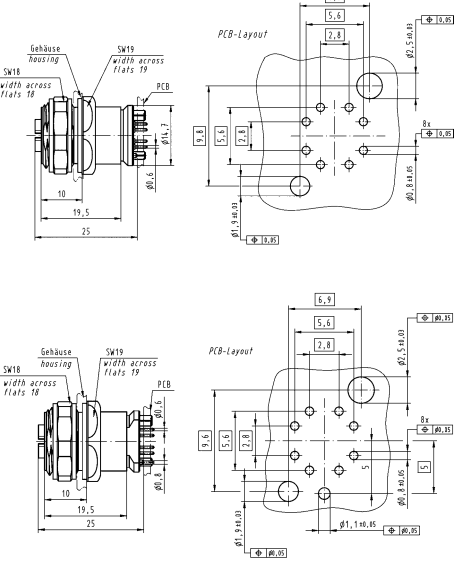
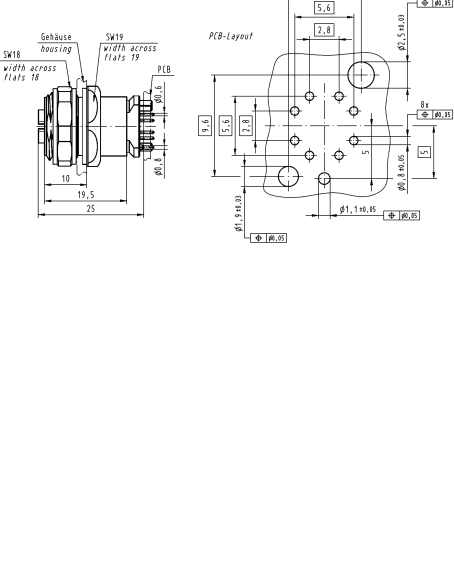
Identification		Part number Female	Drawing (dimensions in mm)
<p>Circular connectors M12, PCB adapter, Straight, incl. housing, for rear mounting, Reflow soldering termination (THR), Shielded</p> 	<p>Cat. 5 Cat. 6A</p>	<p>21 03 381 2812 21 03 381 2811</p>	 <p>Panel cut out</p>  <p>Panel cut out</p>
<p>Circular connectors M12, Long version, PCB adapter, Straight, incl. housing, for rear mounting, Reflow soldering termination (THR), Shielded, Pack contents: 60 pieces in a tray</p> 	<p>Cat. 5 Cat. 6A</p>	<p>21 03 381 2805 21 03 381 2804</p>	 <p>PCB-Layout</p>  <p>PCB-Layout</p>

M12

D03  
12  
-  
51

Number of contacts

8

Reflow soldering termination (THR)  
Shielded

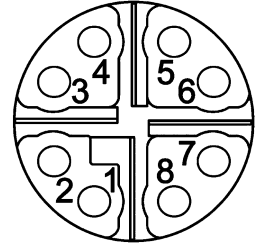

Technical characteristics

Number of contacts	8
Rated current	0.5 A
Rated voltage	50 V
Rated impulse voltage	0.8 kV
Pollution degree	3
Insulation resistance	>10 <sup>8</sup> Ω
Contact resistance	≤10 mΩ
Mating cycles	≥100
Locking type	Screw locking, PushPull
Degree of protection acc. to IEC 60529	IP65 / IP67, when mated
Transmission characteristics	Cat. 6A, Class E <sub>A</sub> up to 500 MHz
Tightening torque	2 Nm Lock nut
Material (insert)	Liquid crystal polymer (LCP)

Technical characteristics

Material (hood/housing)	Zinc die-cast
Material (contacts)	Copper alloy
Surface (contacts)	Gold plated
RoHS	compliant with exemption

Specifications and approvals

IEC 61076-2-109  
UL 1977 ECBT2.E102079  
CSA-C22.2 No. 182.3 ECBT8.E102079



Identification

Circular connectors M12,  
PushPull,  
PCB adapter,  
Angled,  
incl. housing,  
for front mounting,  
Reflow soldering termination (THR),  
Shielded,  
Pack contents:  
30 pieces in a tray







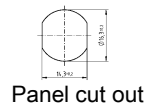
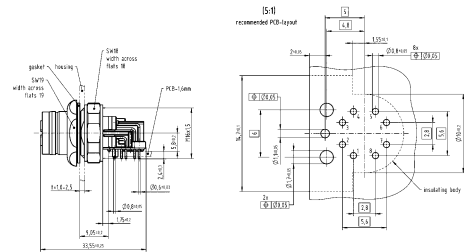

Part number  
Female

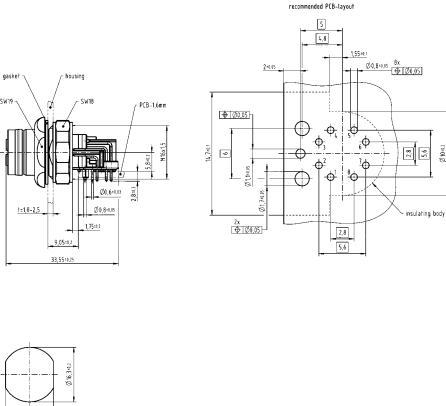
21 03 381 4802

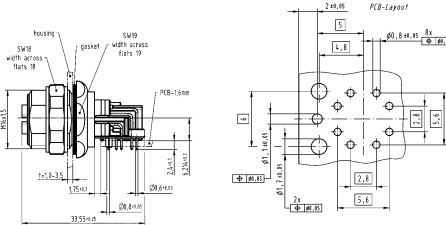
Drawing  
(dimensions in mm)

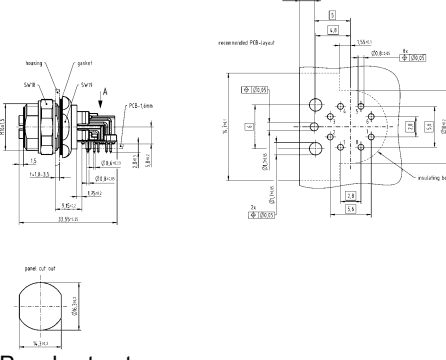

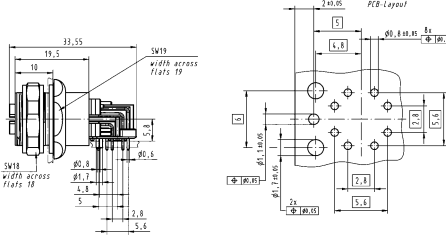
Identification	Part number Female	Drawing (dimensions in mm)
<p>Circular connectors M12, PushPull, PCB adapter, Angled, incl. housing, for front mounting, Reflow soldering termination (THR), Shielded</p> 	<p>21 03 381 4810</p>	 <p>Panel cut out</p>
<p>Circular connectors M12, PCB adapter, Angled, incl. housing, for rear mounting, Reflow soldering termination (THR), Shielded, Pack contents: 30 pieces in a tray</p> 	<p>21 03 381 4807</p>	
<p>Circular connectors M12, PCB adapter, Angled, incl. housing, for rear mounting, Reflow soldering termination (THR), Shielded</p> 	<p>21 03 381 4809</p>	 <p>Panel cut out</p>
<p>Circular connectors M12, Long version, PCB adapter, Angled, incl. housing, for rear mounting, Reflow soldering termination (THR), Shielded, Pack contents: 30 pieces in a tray</p> 	<p>21 03 381 4804</p>	

M12

D03  
12  
-  
53

Number of contacts

8

Reflow soldering termination (SMT)  
Shielded

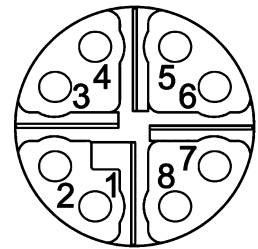

Technical characteristics

Number of contacts	8
Rated current	0.5 A
Rated voltage	48 V
Pollution degree	3
Insulation resistance	>10 <sup>8</sup> Ω
Mating cycles	≥100
Locking type	Screw locking
Degree of protection acc. to IEC 60529	IP67, when mated
Transmission characteristics	Cat. 6A, Class E <sub>A</sub> up to 500 MHz

Technical characteristics

Tightening torque	1 Nm Lock nut
Material (insert)	Liquid crystal polymer (LCP)
Material (contacts)	Copper alloy
Surface (contacts)	Gold plated
RoHS	compliant with exemption

Specifications and approvals

IEC 61076-2-109

Identification

Part number  
Female

Drawing  
(dimensions in mm)

Circular connectors M12,  
PCB adapter,  
Straight,  
Reflow soldering termination (SMT),  
Shielded

21 03 381 2820

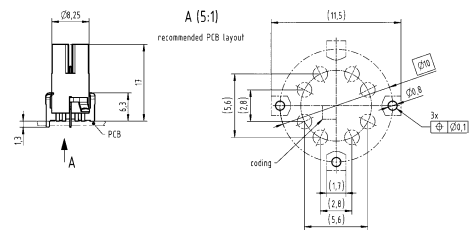

Order housings separately

Circular connectors M12,  
PCB adapter,  
Straight,  
Reflow soldering termination (SMT),  
Shielded,

21 03 381 2821

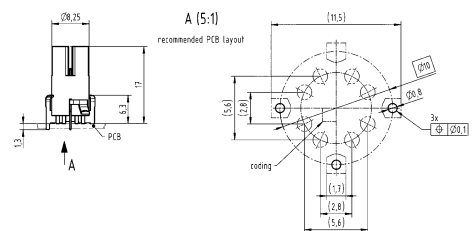

Pack contents:  
75 pieces on reel

Order housings separately

Circular connectors M12,  
Housing,  
for front mounting,  
M14 x 1,  
9 mm

21 41 000 0010

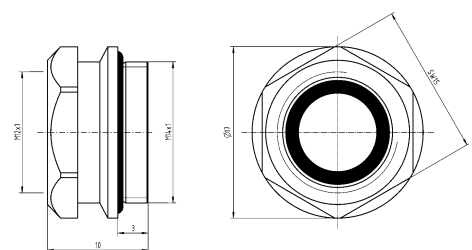

If necessary, order lock nut 21 41 000 0011 separately.

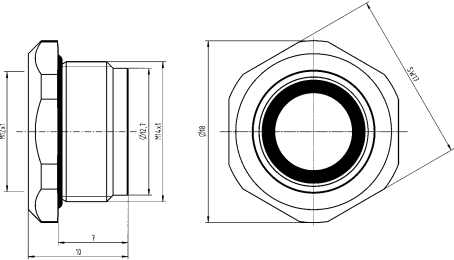
Identification	Part number Female	Drawing (dimensions in mm)
<p>Circular connectors M12, Housing, for front mounting, M14 x 1, 13 mm</p>  <p>If necessary, order lock nut 21 41 000 0011 separately.</p>	<p>21 41 000 0013</p>	

M12

Number of contacts

**4+**

Reflow soldering termination (THR)  
Shielded

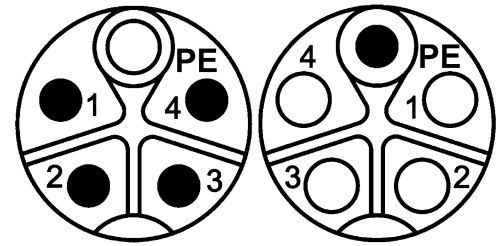

### Technical characteristics



Number of contacts	4
Rated current	12 A
Rated voltage	630 V
Rated impulse voltage	6 kV
Pollution degree	3
Insulation resistance	>10 <sup>8</sup> Ω
Contact resistance	≤10 mΩ
Mating cycles	≥100
Locking type	Screw locking, PushPull
Degree of protection acc. to IEC 60529	IP65 / IP67, when mated

### Technical characteristics

Tightening torque	2 Nm Lock nut
Material (insert)	Liquid crystal polymer (LCP)
Material (contacts)	Copper alloy
Surface (contacts)	Gold plated

### Specifications and approvals

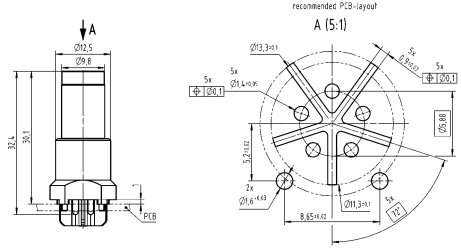
IEC 61076-2-111

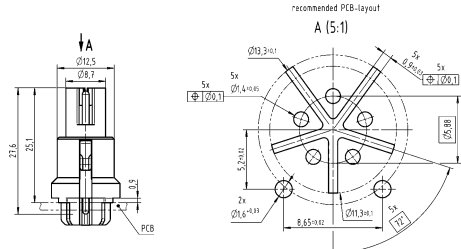
Identification	Part number		Drawing (dimensions in mm)
	Male	Female	
Circular connectors M12, Power, PushPull, PCB adapter, Straight, Reflow soldering termination (THR), Shielded, Pack contents: 30 pieces in a carton box  Order housings separately	21 03 309 1505 407	21 03 309 2505 407	
Circular connectors M12, Power, PushPull, PCB adapter, Straight, Reflow soldering termination (THR), Shielded, Pack contents: 60 pieces in a tray  Order housings separately	21 03 309 1505	21 03 309 2505	



Identification	Part number		Drawing (dimensions in mm)
	Male	Female	
Circular connectors M12, Housing, for rear mounting, Pack contents: 30 pieces	21 03 302 1000 407	21 03 302 2000 407	
Circular connectors M12, Housing, for front mounting, Pack contents: 30 pieces	21 03 302 1001 407	21 03 302 2001 407	



M12

Number of contacts

**4+**

Reflow soldering termination (THR)  
Shielded

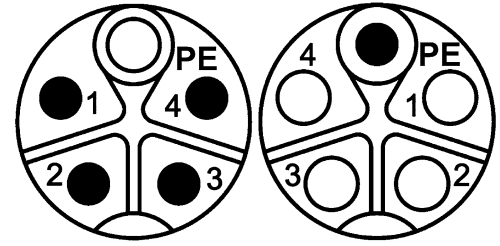

### Technical characteristics

Number of contacts	4
Rated current	12 A
Rated voltage	630 V
Rated impulse voltage	6 kV
Pollution degree	3
Insulation resistance	>10 <sup>8</sup> Ω
Contact resistance	≤10 mΩ
Mating cycles	≥100
Locking type	Screw locking, PushPull
Degree of protection acc. to IEC 60529	IP65 / IP67, when mated

### Technical characteristics

Tightening torque	2 Nm Lock nut
Material (insert)	Liquid crystal polymer (LCP)
Material (contacts)	Copper alloy
Surface (contacts)	Gold plated

### Specifications and approvals

IEC 61076-2-111

Identification	Part number		Drawing (dimensions in mm)
	Male	Female	
Circular connectors M12, Power, PCB adapter, Straight, incl. housing, for rear mounting, Reflow soldering termination (THR), Shielded	21 03 309 1530	21 03 309 2530	<p>Panel cut out</p> <p>Panel cut out</p>

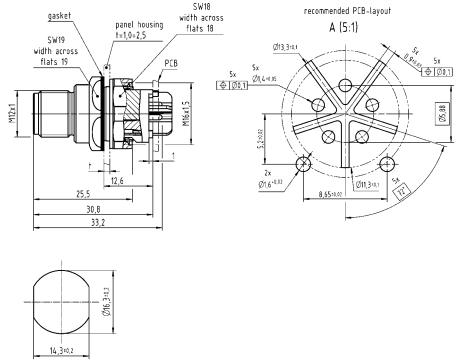
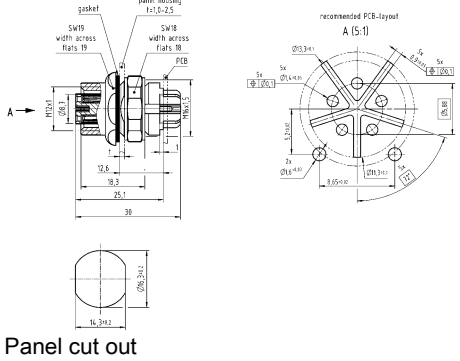

Identification	Part number		Drawing (dimensions in mm)
	Male	Female	
<p>Circular connectors M12, Power, PushPull, PCB adapter, Straight, incl. housing, for front mounting, Reflow soldering termination (THR), Shielded</p> 	21 03 309 1531	21 03 309 2531	 <p>Panel cut out</p>  <p>Panel cut out</p>

M12

D03  
12  
-  
59

Number of contacts

**4**

Reflow soldering termination (THR)  
Shielded

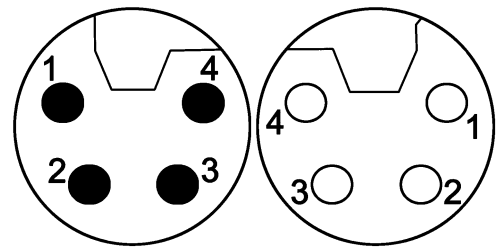

### Technical characteristics

Number of contacts	4
Rated current	16 A
Rated voltage	63 V
Rated impulse voltage	1.5 kV
Pollution degree	3
Insulation resistance	$>10^8 \Omega$
Contact resistance	$\leq 10 \text{ m}\Omega$
Mating cycles	$\geq 100$
Locking type	Screw locking
Degree of protection acc. to IEC 60529	IP65 / IP67, when mated
Tightening torque	2 Nm Lock nut
Material (insert)	Polyamide (PA)

### Technical characteristics



Colour (insert)	Black
Material (contacts)	Copper alloy
Surface (contacts)	Gold plated
RoHS	compliant, compliant with exemption

### Specifications and approvals

IEC 61076-2-111

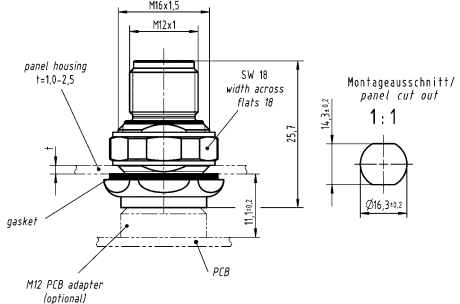
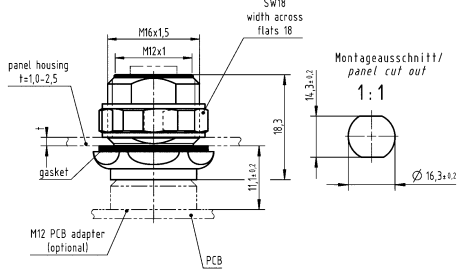

Identification	Part number		Drawing (dimensions in mm)
	Male	Female	
<p>Circular connectors M12, Power, PCB adapter, Straight, Reflow soldering termination (THR), Shielded, Pack contents: 60 pieces in a tray</p> <p>Order housings separately</p>	21 03 396 1506	21 03 396 2506	<p><b>A (5:1)</b> recommended PCB-layout</p> <p><b>A (5:1)</b> recommended PCB-layout</p>

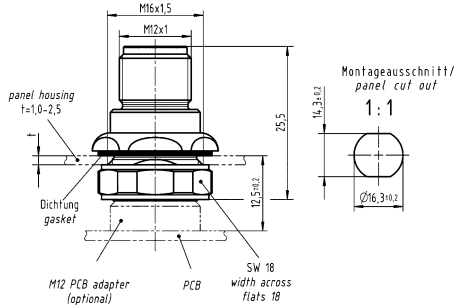
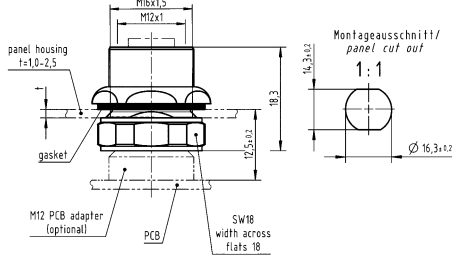
Identification	Part number		Drawing (dimensions in mm)
	Male	Female	
<p>Circular connectors M12, Housing, for rear mounting, Pack contents: 60 pieces</p> 	21 03 302 1000	21 03 302 2000	 
<p>Circular connectors M12, Housing, for front mounting, Pack contents: 60 pieces</p> 	21 03 302 1001	21 03 302 2001	 

M12

D03  
12  
·  
61

Number of contacts

**4**

Reflow soldering termination (THR)  
Shielded

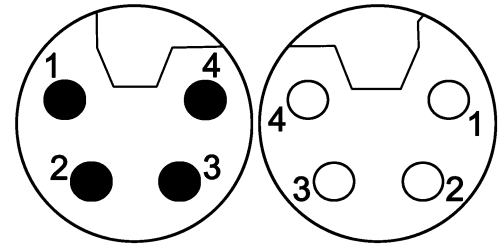

### Technical characteristics

Number of contacts	4
Rated current	16 A
Rated voltage	63 V
Rated impulse voltage	1.5 kV
Pollution degree	3
Insulation resistance	>10 <sup>8</sup> Ω
Contact resistance	≤10 mΩ
Mating cycles	≥100
Locking type	Screw locking
Degree of protection acc. to IEC 60529	IP65 / IP67, when mated
Tightening torque	2 Nm Lock nut
Material (insert)	Polyamide (PA)

### Technical characteristics

Colour (insert)	Black
Material (hood/housing)	Zinc die-cast
Material (contacts)	Copper alloy
Surface (contacts)	Gold plated
RoHS	compliant

### Specifications and approvals

IEC 61076-2-111



Identification	Part number		Drawing (dimensions in mm)
	Male	Female	
Circular connectors M12, Power, PCB adapter, Straight, incl. housing, for front mounting, Reflow soldering termination (THR), Shielded	21 03 396 1532	21 03 396 2532	<p>Panel cut out</p> <p>Panel cut out</p>

D03  
12  
·  
62

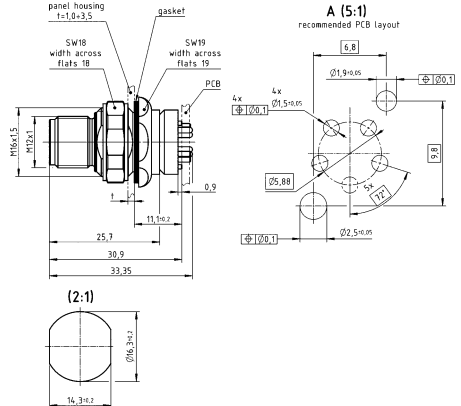
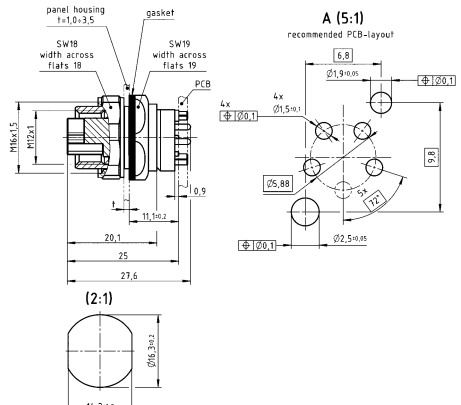
Identification	Part number		Drawing (dimensions in mm)
	Male	Female	
<p>Circular connectors M12, Power, PCB adapter, Straight, incl. housing, for rear mounting, Reflow soldering termination (THR), Shielded</p> 	21 03 396 1533	21 03 396 2533	 <p>Panel cut out</p>  <p>Panel cut out</p>

M12

Number of contacts

**4+**

Reflow soldering termination (THR)  
Shielded

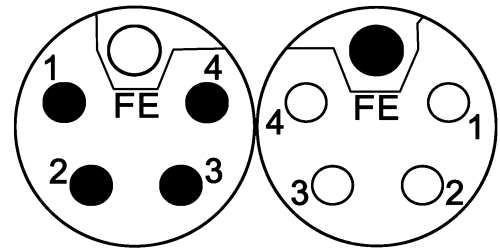

### Technical characteristics

Number of contacts	4
Rated current	16 A
Rated voltage	63 V
Rated impulse voltage	1.5 kV
Pollution degree	3
Insulation resistance	>10 <sup>8</sup> Ω
Contact resistance	≤10 mΩ
Mating cycles	≥100
Locking type	Screw locking
Degree of protection acc. to IEC 60529	IP65 / IP67, when mated
Tightening torque	2 Nm Lock nut
Material (insert)	Polyamide (PA)

### Technical characteristics



Colour (insert)	Grey
Material (contacts)	Copper alloy
Surface (contacts)	Gold plated
RoHS	compliant with exemption

### Specifications and approvals

IEC 61076-2-111

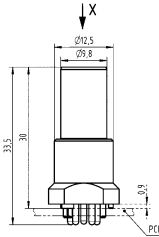
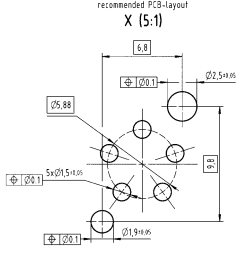
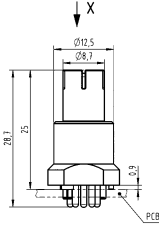
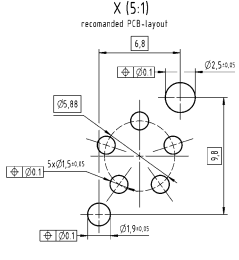

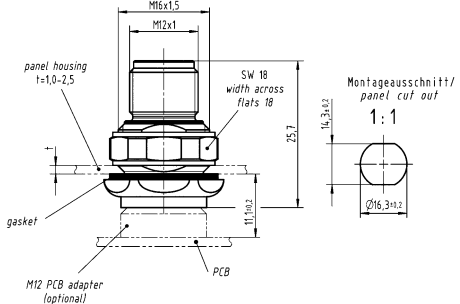
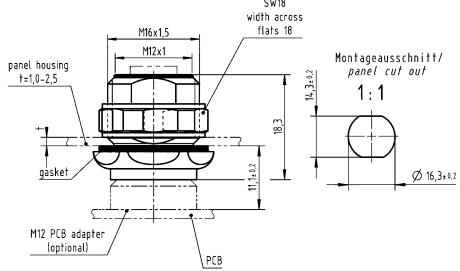
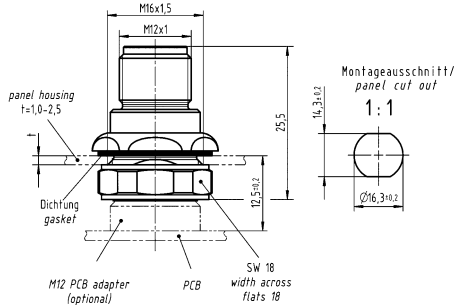
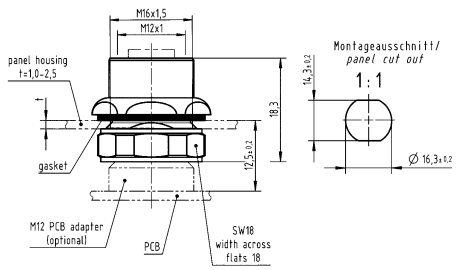
Identification	Part number		Drawing (dimensions in mm)
	Male	Female	
Circular connectors M12, Power, PCB adapter, Straight, Reflow soldering termination (THR), Shielded, Pack contents: 60 pieces in a tray  Order housings separately	21 03 396 1505	21 03 396 2505	   

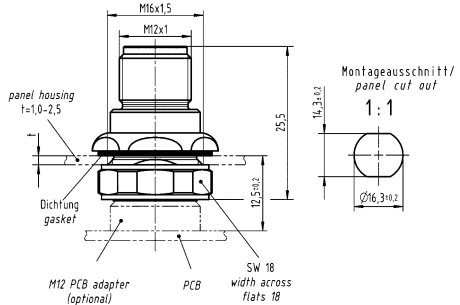
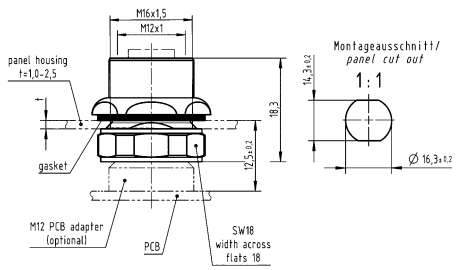
Identification	Part number		Drawing (dimensions in mm)
	Male	Female	
<p>Circular connectors M12, Housing, for rear mounting, Pack contents: 60 pieces</p> 	21 03 302 1000	21 03 302 2000	   
<p>Circular connectors M12, Housing, for front mounting, Pack contents: 60 pieces</p> 	21 03 302 1001	21 03 302 2001	 

M12

D03  
12  
-  
65

Number of contacts

**4+**

Reflow soldering termination (THR)  
Shielded

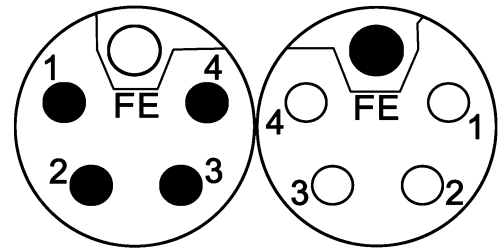

**Technical characteristics**

Number of contacts	4
Rated current	16 A
Rated voltage	63 V
Rated impulse voltage	1.5 kV
Pollution degree	3
Insulation resistance	>10 <sup>8</sup> Ω
Contact resistance	≤10 mΩ
Mating cycles	≥100
Locking type	Screw locking
Degree of protection acc. to IEC 60529	IP65 / IP67, when mated
Tightening torque	2 Nm Lock nut
Material (insert)	Polyamide (PA)

**Technical characteristics**

Colour (insert)	Grey
Material (hood/housing)	Zinc die-cast
Material (contacts)	Copper alloy
Surface (contacts)	Gold plated
RoHS	compliant with exemption

**Specifications and approvals**

IEC 61076-2-111



Identification	Part number		Drawing (dimensions in mm)
	Male	Female	
Circular connectors M12, Power, PCB adapter, Straight, incl. housing, for rear mounting, Reflow soldering termination (THR), Shielded	21 03 396 1530	21 03 396 2530	

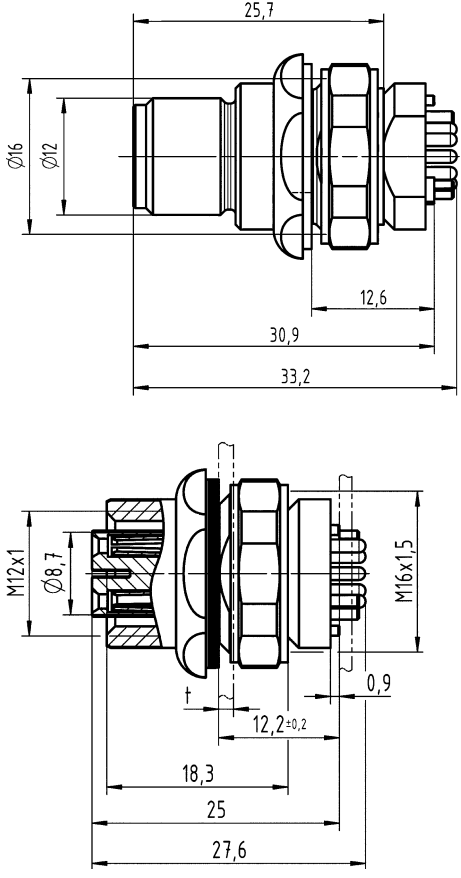

Identification	Part number		Drawing (dimensions in mm)
	Male	Female	
<p>Circular connectors M12, Power, PCB adapter, Straight, incl. housing, for front mounting, Reflow soldering termination (THR), Shielded</p> 	21 03 396 1531	21 03 396 2531	

M12

D03  
12  
·  
67

Number of contacts

3+

Reflow soldering termination (THR)  
Shielded

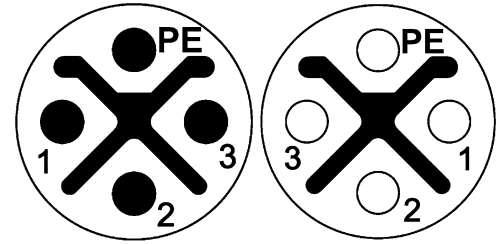

Technical characteristics

Number of contacts	3
Rated current	12 A
Rated voltage	630 V
Rated impulse voltage	6 kV
Pollution degree	3
Insulation resistance	>10 <sup>8</sup> Ω
Contact resistance	≤10 mΩ
Mating cycles	≥100
Locking type	Screw locking, PushPull
Degree of protection acc. to IEC 60529	IP65 / IP67, when mated

Technical characteristics

Tightening torque	2 Nm Lock nut
Material (insert)	Liquid crystal polymer (LCP)
Material (contacts)	Copper alloy
Surface (contacts)	Gold plated

Specifications and approvals

IEC 61076-2-111

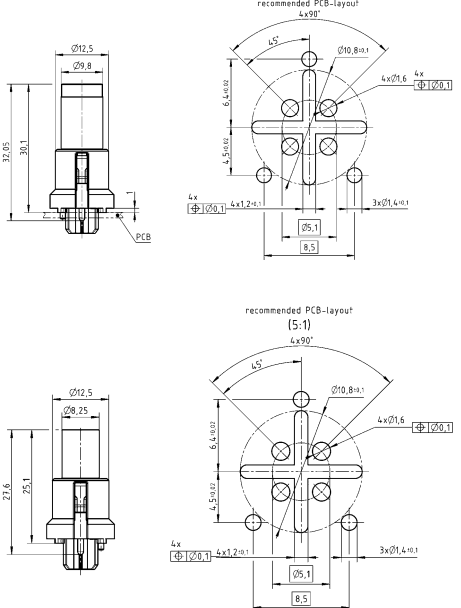
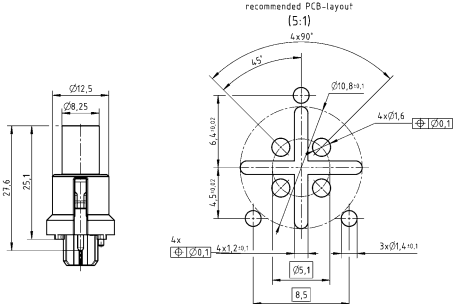
Identification	Part number		Drawing (dimensions in mm)
	Male	Female	
Circular connectors M12, Power, PushPull, PCB adapter, Straight, Reflow soldering termination (THR), Shielded, Pack contents: 30 pieces in a carton box   Order housings separately	21 03 399 1430	21 03 399 2430	
Circular connectors M12, Power, PushPull, PCB adapter, Straight, Reflow soldering termination (THR), Shielded, Pack contents: 60 pieces in a tray Order housings separately	21 03 399 1460	21 03 399 2460	
Circular connectors M12, Housing, for rear mounting, Pack contents: 30 pieces	21 03 302 1000 407	21 03 302 2000 407	



Identification	Part number		Drawing (dimensions in mm)
	Male	Female	
Circular connectors M12, Housing, for front mounting, Pack contents: 30 pieces	21 03 302 1001 407	21 03 302 2001 407	



M12

Number of contacts

**3+**

Reflow soldering termination (THR)  
Shielded

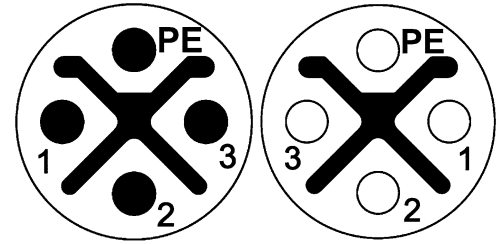

**Technical characteristics**

Number of contacts	3
Rated current	12 A
Rated voltage	630 V
Rated impulse voltage	6 kV
Pollution degree	3
Insulation resistance	>10 <sup>8</sup> Ω
Contact resistance	≤10 mΩ
Mating cycles	≥100
Locking type	Screw locking
Degree of protection acc. to IEC 60529	IP65 / IP67, when mated

**Technical characteristics**

Tightening torque	2 Nm Lock nut
Material (insert)	Liquid crystal polymer (LCP)
Material (contacts)	Copper alloy
Surface (contacts)	Gold plated

**Specifications and approvals**

IEC 61076-2-111

Identification	Part number		Drawing (dimensions in mm)
	Male	Female	
Circular connectors M12, Power, PCB adapter, Straight, Reflow soldering termination (THR), Shielded, Pack contents: incl. housing	21 03 399 1403	21 03 399 2403	<p>Panel cut out</p> <p>Panel cut out</p>



Number of contacts

4

Reflow soldering termination (SMT)  
Shielded

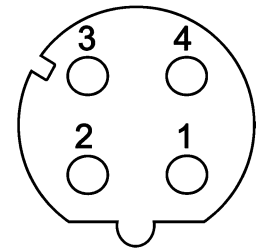

M12

Technical characteristics



Number of contacts	4
Rated current	3 A
Rated voltage	57 V
Rated impulse voltage	1.5 kV
Pollution degree	3
Insulation resistance	>10 <sup>8</sup> Ω
Contact resistance	≤10 mΩ
Mating cycles	≥100
Locking type	Screw locking, PushPull
Degree of protection acc. to IEC 60529	IP65 / IP67, when mated
Transmission characteristics	Cat. 5, Class D up to 100 MHz

Technical characteristics

Data rate	100 Mbit/s
Tightening torque	2 Nm Lock nut
Material (insert)	Liquid crystal polymer (LCP)
Material (contacts)	Brass
Surface (contacts)	Gold plated
Material (accessories)	Brass, nickel plated
RoHS	compliant with exemption

Specifications and approvals

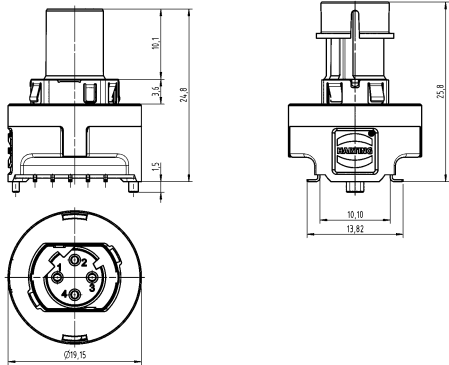
IEC 61076-2-101

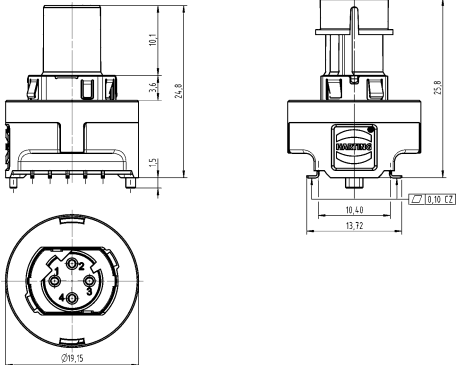
Identification	Part number Female	Drawing (dimensions in mm)
<p>Circular connectors M12, Magnetics, PCB adapter, with integrated transformer, Straight, Reflow soldering termination (SMT), Shielded,</p> <p>Pack contents: 60 pieces in a tray</p>  <p>Order housings separately</p>	21 03 381 2410	
<p>Circular connectors M12, Magnetics, PCB adapter, with integrated transformer, Straight, Power over Ethernet (PoE+), Reflow soldering termination (SMT), Shielded,</p> <p>Pack contents: 60 pieces in a tray</p>  <p>Order housings separately</p>	21 03 381 2411	





Number of contacts

**4**

Reflow soldering termination (SMT)  
Shielded

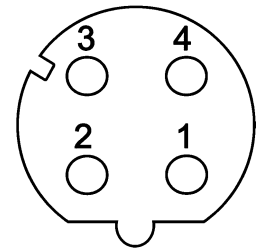

### Technical characteristics



Number of contacts	4
Rated current	3 A
Rated voltage	57 V
Rated impulse voltage	1.5 kV
Pollution degree	3
Insulation resistance	>10 <sup>8</sup> Ω
Contact resistance	≤10 mΩ
Mating cycles	≥100
Locking type	Screw locking, PushPull
Degree of protection acc. to IEC 60529	IP65 / IP67, when mated
Transmission characteristics	Cat. 5, Class D up to 100 MHz

### Technical characteristics

Data rate	100 Mbit/s
Tightening torque	2 Nm Lock nut
Material (insert)	Liquid crystal polymer (LCP)
Material (contacts)	Brass
Surface (contacts)	Gold plated
RoHS	compliant with exemption

### Specifications and approvals

IEC 61076-2-101

Identification	Part number Female	Drawing (dimensions in mm)
<p>Circular connectors M12, Magnetics, PushPull, PCB adapter, with integrated transformer, Straight, incl. housing, Power over Ethernet (PoE+), for front mounting, Reflow soldering termination (SMT), Shielded</p> 	21 03 381 2421	
<p>Circular connectors M12, Magnetics, PushPull, PCB adapter, with integrated transformer, Angled, incl. housing, Power over Ethernet (PoE+), for front mounting, Reflow soldering termination (SMT), Shielded</p> 	21 03 381 4422	

Number of contacts

8

Reflow soldering termination (SMT)  
Shielded

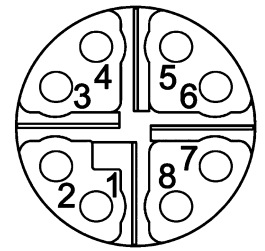

M12

Technical characteristics



Number of contacts	8
Rated current	0.8 A
Rated voltage	57 V
Rated impulse voltage	1.5 kV
Pollution degree	3
Insulation resistance	>10 <sup>8</sup> Ω
Contact resistance	≤10 mΩ
Mating cycles	≥100
Locking type	Screw locking, PushPull
Degree of protection acc. to IEC 60529	IP65 / IP67, when mated
Transmission characteristics	Cat. 6A, Class E <sub>A</sub> up to 500 MHz

Technical characteristics

Data rate	1 Gbit/s
Tightening torque	2 Nm Lock nut
Material (insert)	Liquid crystal polymer (LCP)
Material (contacts)	Brass
Surface (contacts)	Gold plated
Material (accessories)	Brass, nickel plated
RoHS	compliant with exemption





Specifications and approvals

IEC 61076-2-109

Identification	Part number Female	Drawing (dimensions in mm)
<p>Circular connectors M12, Magnetics, PCB adapter, with integrated transformer, Straight, Reflow soldering termination (SMT), Shielded,</p> <p>Pack contents: 60 pieces in a tray</p>  <p>Order housings separately</p>	21 03 381 2815	
<p>Circular connectors M12, Magnetics, PCB adapter, with integrated transformer, Straight, Power over Ethernet (PoE+), Reflow soldering termination (SMT), Shielded,</p> <p>Pack contents: 60 pieces in a tray</p>  <p>Order housings separately</p>	21 03 381 2817	

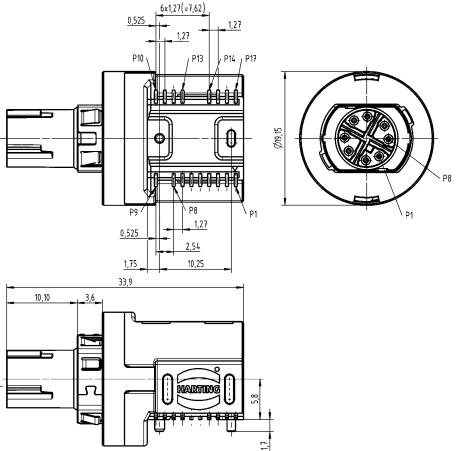
D03  
12  
-  
75

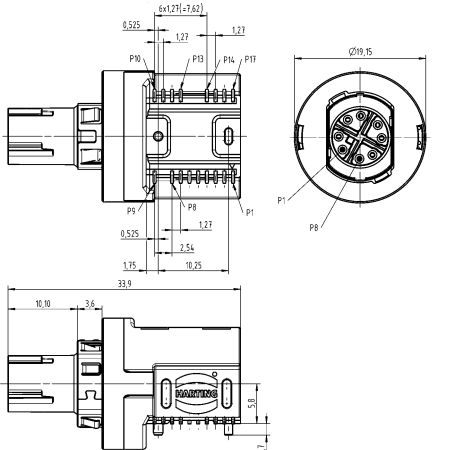
M12

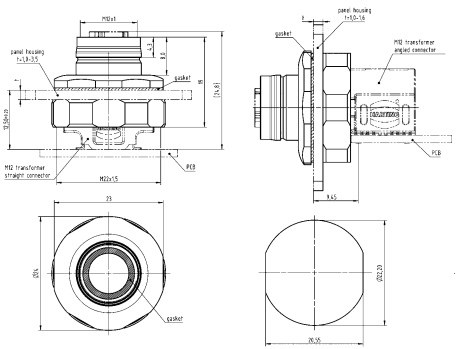
Identification	Part number Female	Drawing (dimensions in mm)
<p>Circular connectors M12, Magnetics, PCB adapter, with integrated transformer, Angled, Reflow soldering termination (SMT), Shielded,</p> <p>Pack contents: 30 pieces in a tray</p>  <p>Order housings separately</p>	<p>21 03 381 4820</p>	
<p>Circular connectors M12, Magnetics, PCB adapter, with integrated transformer, Angled, Power over Ethernet (PoE+), Reflow soldering termination (SMT), Shielded,</p> <p>Pack contents: 30 pieces in a tray</p>  <p>Order housings separately</p>	<p>21 03 381 4822</p>	
<p>Circular connectors M12, PushPull, Housing, for front mounting,</p> <p>Pack contents: 30 pieces</p> 	<p>21 03 301 2006</p>	 <p>Panel cut out</p>

Identification	Part number Female	Drawing (dimensions in mm)
----------------	-----------------------	-------------------------------

Circular connectors M12,  
Housing,  
for rear mounting,  
Pack contents:  
30 pieces



21 03 301 2007

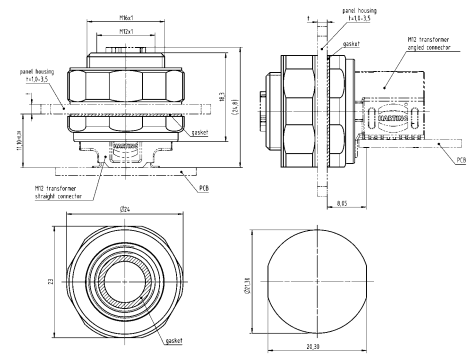

Panel cut out

M12

Number of contacts

8

Reflow soldering termination (SMT)  
Shielded

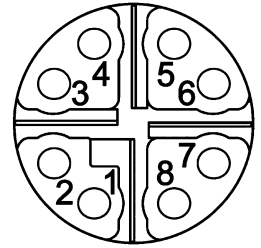

### Technical characteristics



Number of contacts	8
Rated current	0.8 A
Rated voltage	57 V
Rated impulse voltage	1.5 kV
Pollution degree	3
Insulation resistance	>10 <sup>8</sup> Ω
Contact resistance	≤10 mΩ
Mating cycles	≥100
Locking type	Screw locking, PushPull
Degree of protection acc. to IEC 60529	IP65 / IP67, when mated
Transmission characteristics	Cat. 6A, Class E <sub>A</sub> up to 500 MHz

### Technical characteristics

Data rate	1 Gbit/s
Tightening torque	2 Nm Lock nut
Material (insert)	Liquid crystal polymer (LCP)
Material (contacts)	Brass
Surface (contacts)	Gold plated
RoHS	compliant with exemption

### Specifications and approvals

IEC 61076-2-109

Identification	Part number Female	Drawing (dimensions in mm)
<p>Circular connectors M12, Magnetics, PushPull, PCB adapter, with integrated transformer, Straight, incl. housing, Power over Ethernet (PoE+), for front mounting, Reflow soldering termination (SMT), Shielded</p> 	21 03 381 2824	
<p>Circular connectors M12, Magnetics, PushPull, PCB adapter, with integrated transformer, Angled, incl. housing, Power over Ethernet (PoE+), for front mounting, Reflow soldering termination (SMT), Shielded</p> 	21 03 381 4826	

Number of contacts

# 8

Reflow soldering termination (SMT)  
Shielded

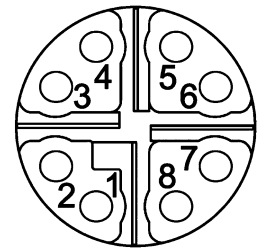

M12

## Technical characteristics



Number of contacts	8
Rated current	0.8 A
Rated voltage	57 V
Rated impulse voltage	1.5 kV
Pollution degree	3
Insulation resistance	>10 <sup>8</sup> Ω
Contact resistance	≤10 mΩ
Mating cycles	≥100
Locking type	Screw locking, PushPull
Degree of protection acc. to IEC 60529	IP65 / IP67, when mated
Transmission characteristics	Cat. 6A, Class E <sub>A</sub> up to 500 MHz

## Technical characteristics





Data rate	10 Gbit/s
Tightening torque	2 Nm Lock nut
Material (insert)	Liquid crystal polymer (LCP)
Material (contacts)	Brass
Surface (contacts)	Gold plated
Material (accessories)	Brass, nickel plated
RoHS	compliant with exemption

## Specifications and approvals

IEC 61076-2-109

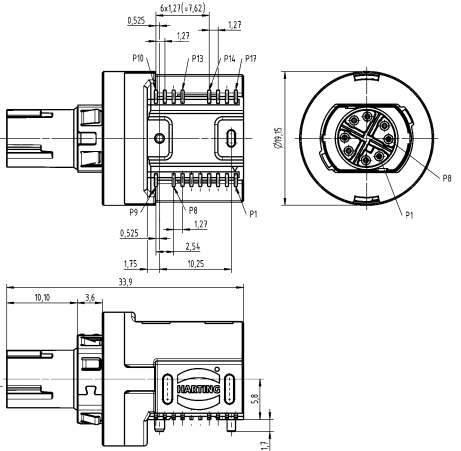
Identification	Part number Female	Drawing (dimensions in mm)
<p>Circular connectors M12, Magnetics, PCB adapter, with integrated transformer, Straight, Reflow soldering termination (SMT), Shielded,</p> <p>Pack contents: 60 pieces in a tray</p>  <p>Order housings separately</p>	21 03 381 2818	
<p>Circular connectors M12, Magnetics, PCB adapter, with integrated transformer, Straight, Power over Ethernet (PoE+), Reflow soldering termination (SMT), Shielded,</p> <p>Pack contents: 60 pieces in a tray</p>  <p>Order housings separately</p>	21 03 381 2823	

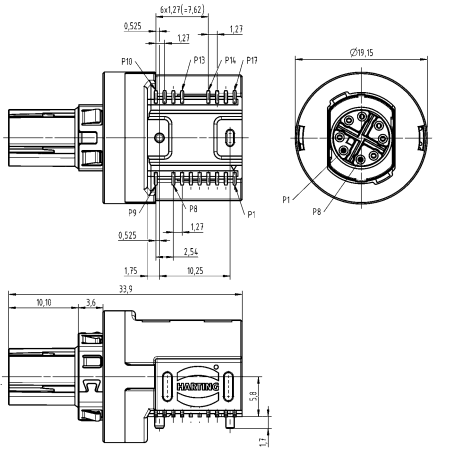
M12

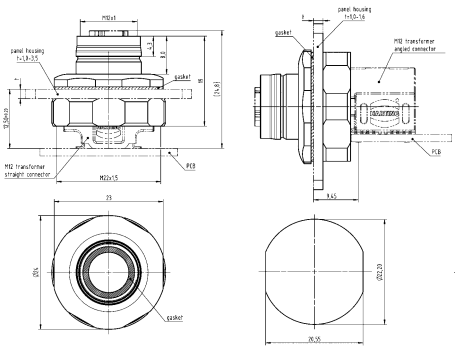
Identification	Part number Female	Drawing (dimensions in mm)
<p>Circular connectors M12, Magnetics, PCB adapter, with integrated transformer, Angled, Reflow soldering termination (SMT), Shielded,</p> <p>Pack contents: 30 pieces in a tray</p>  <p>Order housings separately</p>	<p>21 03 381 4823</p>	
<p>Circular connectors M12, Magnetics, PCB adapter, with integrated transformer, Angled, Power over Ethernet (PoE+), Reflow soldering termination (SMT), Shielded,</p> <p>Pack contents: 30 pieces in a tray</p>  <p>Order housings separately</p>	<p>21 03 381 4825</p>	
<p>Circular connectors M12, PushPull, Housing, for front mounting,</p> <p>Pack contents: 30 pieces</p> 	<p>21 03 301 2006</p>	 <p>Panel cut out</p>

D03  
12  
-  
80

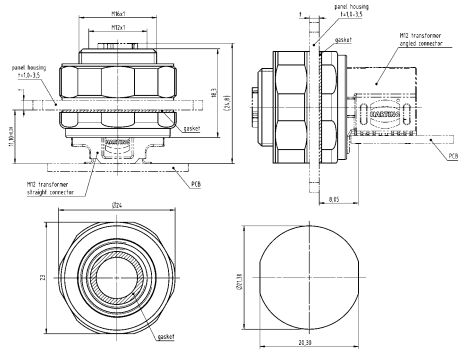
Identification	Part number Female	Drawing (dimensions in mm)
<p>Circular connectors M12, Housing, for rear mounting, Pack contents: 30 pieces</p> 	<p>21 03 301 2007</p>	 <p>Panel cut out</p>

M12

D03  
12  
·  
81

Number of contacts

8

Reflow soldering termination (SMT)  
Shielded

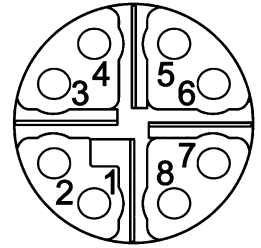

### Technical characteristics



Number of contacts	8
Rated current	0.8 A
Rated voltage	57 V
Rated impulse voltage	1.5 kV
Pollution degree	3
Insulation resistance	>10 <sup>8</sup> Ω
Contact resistance	≤10 mΩ
Mating cycles	≥100
Locking type	Screw locking, PushPull
Degree of protection acc. to IEC 60529	IP65 / IP67, when mated
Transmission characteristics	Cat. 6A, Class E <sub>A</sub> up to 500 MHz

### Technical characteristics

Data rate	10 Gbit/s
Tightening torque	2 Nm Lock nut
Material (insert)	Liquid crystal polymer (LCP)
Material (contacts)	Brass
Surface (contacts)	Gold plated
RoHS	compliant with exemption

### Specifications and approvals

IEC 61076-2-109

Identification	Part number Female	Drawing (dimensions in mm)
<p>Circular connectors M12, Magnetics, PushPull, PCB adapter, with integrated transformer, Straight, incl. housing, Power over Ethernet (PoE+), for front mounting, Reflow soldering termination (SMT), Shielded</p> 	21 03 381 2825	
<p>Circular connectors M12, Magnetics, PushPull, PCB adapter, with integrated transformer, Angled, incl. housing, Power over Ethernet (PoE+), for front mounting, Reflow soldering termination (SMT), Shielded</p> 	21 03 381 4827	

D03  
12  
-  
82

Number of contacts

# 3

Unshielded

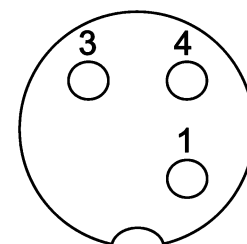

M12

## Technical characteristics

Number of contacts	3
Rated current	4 A
Rated voltage	250 V
Rated impulse voltage	1.5 kV
Pollution degree	3
Insulation resistance	>10 <sup>8</sup> Ω
Contact resistance	≤10 mΩ
Mating cycles	≥100
Locking type	Screw locking
Conductor length	50 cm
Degree of protection acc. to IEC 60529	IP67, when mated
Conductor cross-section	0.25 mm <sup>2</sup>
Conductor cross-section	AWG 24

## Technical characteristics

Tightening torque	2 Nm Lock nut
Material (insert)	Polyamide (PA)
Material (hood/housing)	Zinc die-cast
Material (contacts)	Brass
Surface (contacts)	Gold plated
RoHS	compliant with exemption

## Specifications and approvals

IEC 61076-2-101

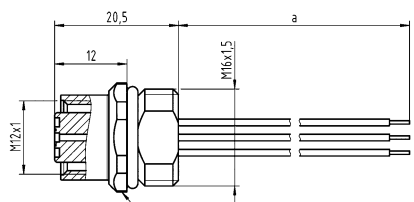

Identification	Conductor cross-section (mm <sup>2</sup> )	Part number Female	Drawing (dimensions in mm)
<p>Circular connectors M12, Panel feed through, With conductors, for front mounting, Unshielded</p>  <p>without lock nut</p>	0.25	21 03 317 6305	 <p>M12 A-coded 3-poles, female straight PFT connector</p>

Number of contacts

# 4

Unshielded

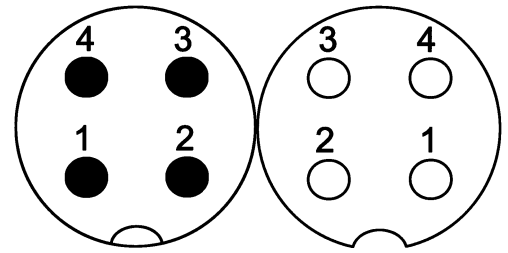

## Technical characteristics

Number of contacts	4
Rated current	4 A
Rated voltage	250 V
Rated impulse voltage	1.5 kV
Pollution degree	3
Insulation resistance	>10 <sup>8</sup> Ω
Contact resistance	≤10 mΩ
Mating cycles	≥100
Locking type	Screw locking
Conductor length	50 cm, 100 cm
Degree of protection acc. to IEC 60529	IP67, when mated
Conductor cross-section	0.5 mm <sup>2</sup> , 0.25 mm <sup>2</sup>
Conductor cross-section	AWG 20, AWG 24
Tightening torque	2 Nm Lock nut

## Technical characteristics

Material (insert)	Polyamide (PA)
Material (hood/housing)	Zinc die-cast
Material (contacts)	Brass
Surface (contacts)	Gold plated
RoHS	compliant with exemption

## Specifications and approvals

IEC 61076-2-101  
 UL 1977 ECBT2.E102079  
 CSA-C22.2 No. 182.3 ECBT8.E102079

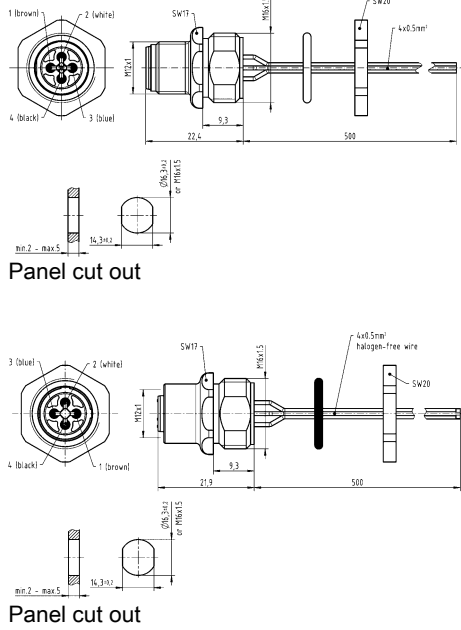

Identification	Conductor cross-section (mm <sup>2</sup> )	Part number		Drawing (dimensions in mm)
		Male	Female	
Circular connectors M12, Panel feed through, With conductors, for front mounting, Unshielded, Pack contents: incl. lock nut 	0.5	21 03 311 1402	21 03 311 2400	 <p>Panel cut out</p> <p>Panel cut out</p>

D03  
12  
·  
84

Identification	Conductor cross-section (mm <sup>2</sup> )	Part number		Drawing (dimensions in mm)
		Male	Female	
Circular connectors M12, Panel feed through, With conductors, for front mounting, Unshielded without lock nut	0.25		21 03 317 6405 21 03 317 6410	<p>M12 A-coded 4-pole, female straight PFT connector</p> <p>21 03 317 6405: a = 50 cm 21 03 317 6410: a = 100 cm</p>

M12

D03  
12  
·  
85

Number of contacts

# 5

Unshielded

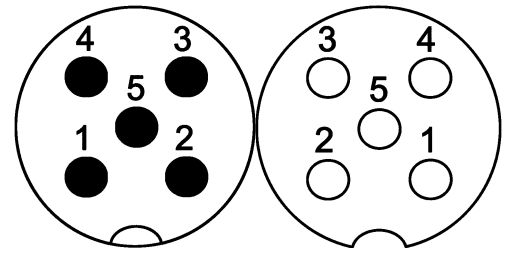

## Technical characteristics

Number of contacts	5
Rated current	4 A
Rated voltage	60 V
Rated impulse voltage	1.5 kV
Pollution degree	3
Insulation resistance	>10 <sup>8</sup> Ω
Contact resistance	≤10 mΩ
Mating cycles	≥100
Locking type	Screw locking
Conductor length	50 cm, 100 cm
Degree of protection acc. to IEC 60529	IP67, when mated
Conductor cross-section	0.5 mm <sup>2</sup> , 0.25 mm <sup>2</sup>
Conductor cross-section	AWG 20, AWG 24
Tightening torque	2 Nm Lock nut

## Technical characteristics

Material (insert)	Polyamide (PA)
Material (hood/housing)	Zinc die-cast
Material (contacts)	Brass
Surface (contacts)	Gold plated
RoHS	compliant with exemption

## Specifications and approvals

IEC 61076-2-101  
 UL 1977 ECBT2.E102079  
 CSA-C22.2 No. 182.3 ECBT8.E102079

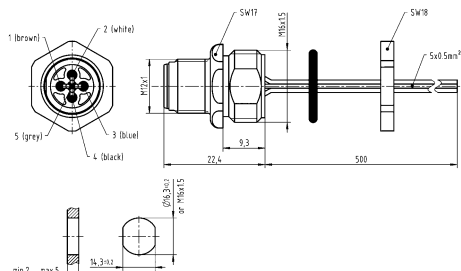
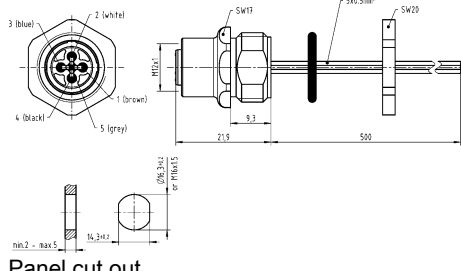
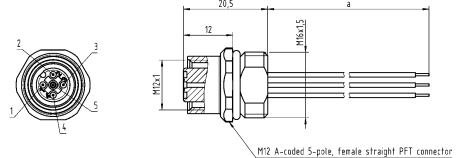

Identification	Conductor cross-section (mm <sup>2</sup> )	Part number		Drawing (dimensions in mm)
		Male	Female	
Circular connectors M12, Panel feed through, With conductors, for front mounting, Unshielded, Pack contents: incl. lock nut 	0.5	21 03 311 1501	21 03 311 2501	 <p>Panel cut out</p>  <p>Panel cut out</p>
Circular connectors M12, Panel feed through, With conductors, for front mounting, Unshielded without lock nut	0.25		21 03 317 6505 21 03 317 6510	 <p>M12 A-coded 5-pole, female straight PFT connector</p> <p>21 03 317 6505: a = 50 cm                      21 03 317 6510: a = 100 cm</p>

D03  
12  
-  
86

Number of contacts

# 8

Unshielded

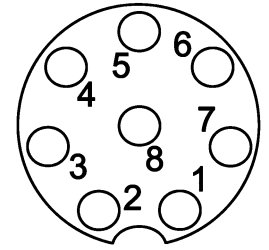

M12

## Technical characteristics

Number of contacts	8
Rated current	2 A
Rated voltage	30 V
Rated impulse voltage	1.5 kV
Pollution degree	3
Insulation resistance	$>10^8 \Omega$
Contact resistance	$\leq 10 \text{ m}\Omega$
Mating cycles	$\geq 100$
Locking type	Screw locking
Conductor length	50 cm, 100 cm
Degree of protection acc. to IEC 60529	IP67, when mated
Conductor cross-section	0.25 mm <sup>2</sup>
Conductor cross-section	AWG 24

## Technical characteristics

Tightening torque	2 Nm Lock nut
Material (insert)	Polyamide (PA)
Material (hood/housing)	Zinc die-cast
Material (contacts)	Brass
Surface (contacts)	Gold plated
RoHS	compliant with exemption

## Specifications and approvals

IEC 61076-2-101

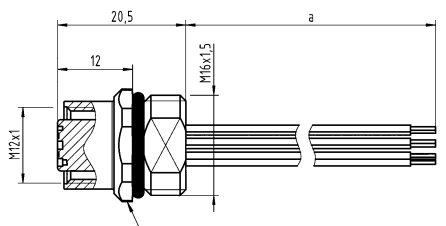

Identification	Conductor cross-section (mm <sup>2</sup> )	Part number Female	Drawing (dimensions in mm)
Circular connectors M12, Panel feed through, With conductors, for front mounting, Unshielded    without lock nut	0.25 0.25	21 03 317 6805 21 03 317 6810	 M12 A-coded 8-poles, female straight PFT connector 21 03 317 6805: a = 50 cm 21 03 317 6810: a = 100 cm

Number of contacts

**12**

Unshielded

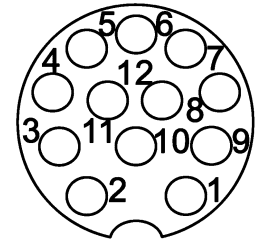

### Technical characteristics

Number of contacts	12
Rated impulse voltage	1.5 kV
Pollution degree	3
Insulation resistance	$>10^8 \Omega$
Contact resistance	$\leq 10 \text{ m}\Omega$
Mating cycles	$\geq 100$
Locking type	Screw locking
Conductor length	50 cm
Degree of protection acc. to IEC 60529	IP67, when mated
Conductor cross-section	0.13 mm <sup>2</sup>
Conductor cross-section	AWG 26
Tightening torque	2 Nm Lock nut

### Technical characteristics

Material (insert)	Polyamide (PA)
Material (hood/housing)	Zinc die-cast
Material (contacts)	Brass
Surface (contacts)	Gold plated
RoHS	compliant with exemption

### Specifications and approvals

IEC 61076-2-101

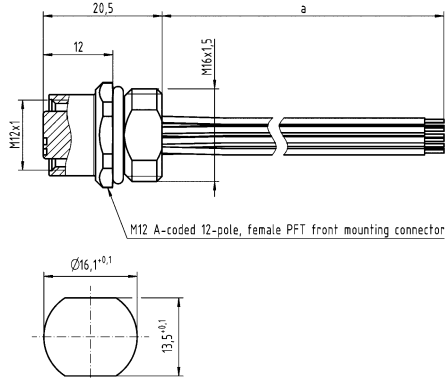

Identification	Conductor cross-section (mm <sup>2</sup> )	Part number Female	Drawing (dimensions in mm)
<p>Circular connectors M12, Panel feed through, With conductors, for front mounting, Unshielded</p>  <p>without lock nut</p>	0.13	21 03 353 2C00	 <p>M12 A-coded 12-pole, female PFT front mounting connector</p> <p>Panel cut out</p>

Number of contacts

# 4

Unshielded

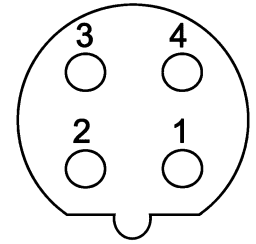

M12

## Technical characteristics

Number of contacts	4
Rated current	4 A
Rated voltage	60 V
Rated impulse voltage	1.5 kV
Pollution degree	3
Insulation resistance	$>10^8 \Omega$
Contact resistance	$\leq 10 \text{ m}\Omega$
Mating cycles	$\geq 100$
Locking type	Screw locking
Conductor length	50 cm
Degree of protection acc. to IEC 60529	IP67, when mated
Conductor cross-section	0.34 mm <sup>2</sup>

## Technical characteristics

Conductor cross-section	AWG 22
Tightening torque	2 Nm Lock nut
Material (insert)	Polyamide (PA)
Material (hood/housing)	Zinc die-cast
Material (contacts)	Brass
Surface (contacts)	Gold plated
RoHS	compliant with exemption

## Specifications and approvals

IEC 61076-2-101

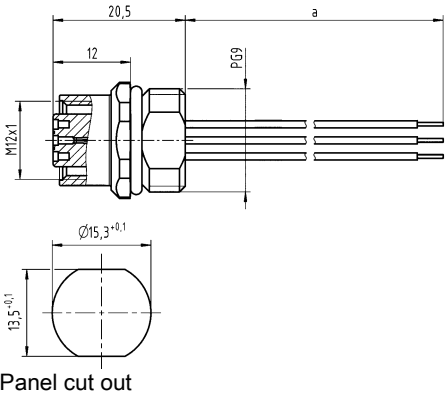
Identification	Conductor cross-section (mm <sup>2</sup> )	Part number Female	Drawing (dimensions in mm)
<p>Circular connectors M12, Panel feed through, With conductors, for front mounting, Unshielded</p>  <p>without lock nut</p>	0.34	21 03 338 6405	 <p>Panel cut out</p>

Number of contacts

# 5

Unshielded

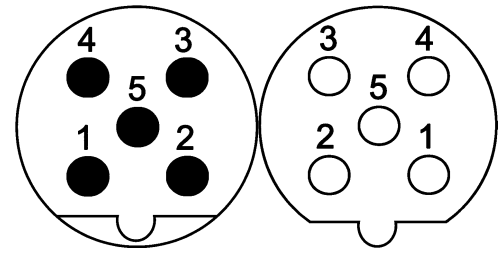

## Technical characteristics

Number of contacts	5
Rated current	4 A
Rated voltage	60 V
Rated impulse voltage	1.5 kV
Pollution degree	3
Insulation resistance	>10 <sup>8</sup> Ω
Contact resistance	≤10 mΩ
Mating cycles	≥100
Locking type	Screw locking
Conductor length	20 cm
Degree of protection acc. to IEC 60529	IP67, when mated
Conductor cross-section	0.34 mm <sup>2</sup>
Conductor cross-section	AWG 22

## Technical characteristics

Tightening torque	2 Nm Lock nut
Material (insert)	Polyamide (PA)
Material (hood/housing)	Zinc die-cast
Material (contacts)	Brass
Surface (contacts)	Gold plated
RoHS	compliant, compliant with exemption

## Specifications and approvals

IEC 61076-2-101  
 UL 1977 ECBT2.E102079  
 CSA-C22.2 No. 182.3 ECBT8.E102079

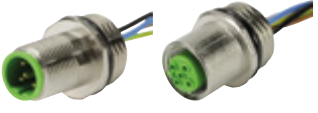
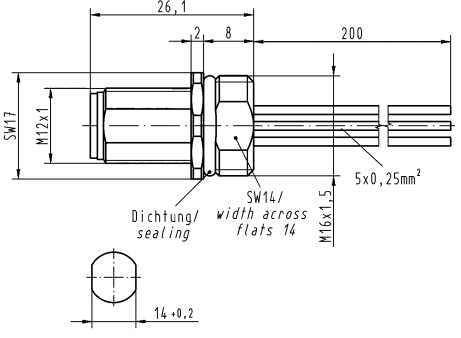
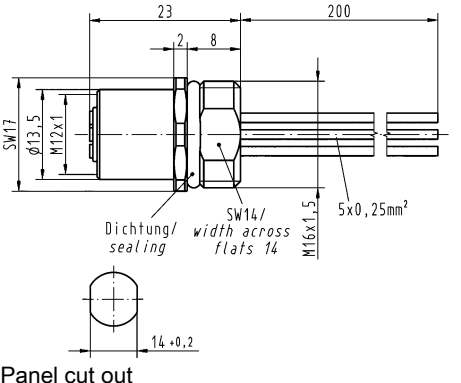
Identification	Conductor cross-section (mm <sup>2</sup> )	Part number		Drawing (dimensions in mm)
		Male	Female	
Circular connectors M12, Panel feed through, With conductors, for front mounting, Unshielded 	0.34	21 03 339 1301	21 03 339 2301	 <p>Panel cut out</p>  <p>Panel cut out</p>

D03  
12  
·  
90

Number of contacts

# 4

Unshielded

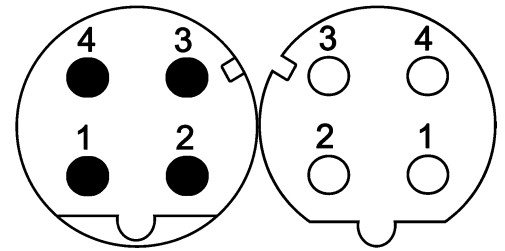

M12

## Technical characteristics

Number of contacts	4
Rated current	4 A
Rated voltage	250 V
Rated impulse voltage	1.5 kV
Pollution degree	3
Insulation resistance	>10 <sup>8</sup> Ω
Contact resistance	≤10 mΩ
Mating cycles	≥100
Locking type	Screw locking
Conductor length	50 cm
Degree of protection acc. to IEC 60529	IP67, when mated
Conductor cross-section	0.34 mm <sup>2</sup> , 0.5 mm <sup>2</sup>
Conductor cross-section	AWG 22, AWG 20
Transmission characteristics	Cat. 5, Class D up to 100 MHz
Tightening torque	2 Nm Lock nut

## Technical characteristics

Material (insert)	Polyamide (PA)
Material (hood/housing)	Zinc die-cast
Material (contacts)	Brass
Surface (contacts)	Gold plated
RoHS	compliant with exemption

## Specifications and approvals

IEC 61076-2-101  
 UL 1977 ECBT2.E102079  
 CSA-C22.2 No. 182.3 ECBT8.E102079

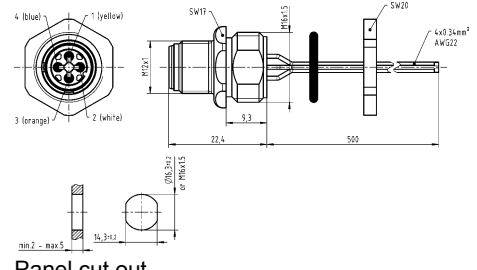
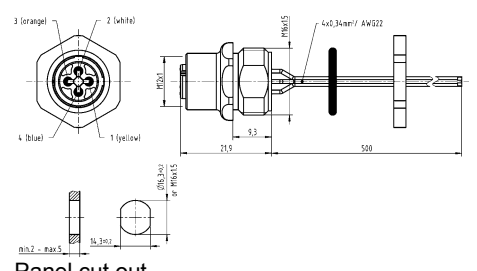
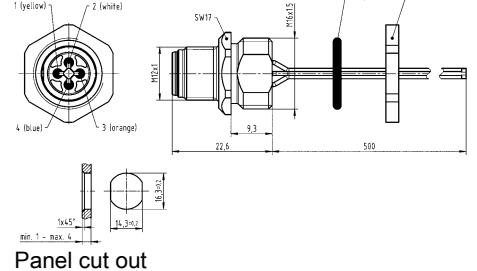

Identification	Conductor cross-section (mm <sup>2</sup> )	Part number		Drawing (dimensions in mm)
		Male	Female	
Circular connectors M12, Panel feed through, With conductors, for front mounting, Unshielded 	0.34 0.5	21 03 371 1403 21 03 371 1405	21 03 371 2403	 <p>Panel cut out</p>  <p>Panel cut out</p>  <p>Panel cut out</p>

D03  
12  
·  
91

M12

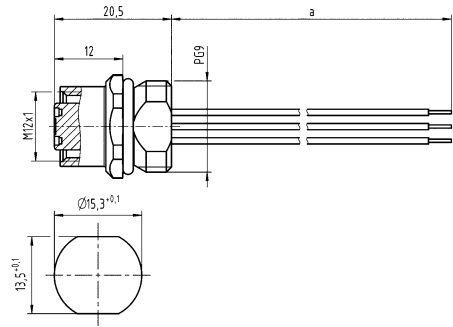
Identification	Conductor cross-section (mm <sup>2</sup> )	Part number		Drawing (dimensions in mm)
		Male	Female	
<p>Circular connectors M12, Panel feed through, With conductors, for front mounting, Unshielded</p>  <p>without lock nut</p>	0.34		21 03 375 2400	 <p>Panel cut out</p>

Number of contacts

# 8

4x 2x AWG 24/7  
Shielded

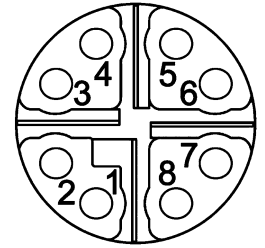

M12

## Technical characteristics

Number of contacts	8
Core structure	4x 2x AWG 24/7, 4x 2x AWG 26/7
Rated current	0.5 A
Rated voltage	50 V
Rated impulse voltage	1.5 kV
Pollution degree	3
Insulation resistance	>10 <sup>8</sup> Ω
Contact resistance	≤10 mΩ
Mating cycles	≥100
Locking type	Screw locking, PushPull
Degree of protection acc. to IEC 60529	IP65 / IP67, when mated
Transmission characteristics	Cat. 6A, Class E <sub>A</sub> up to 500 MHz
Tightening torque	2 Nm Lock nut

## Technical characteristics

Material (insert)	Liquid crystal polymer (LCP)
Material (hood/housing)	Zinc die-cast
Material (contacts)	Brass
Surface (contacts)	Gold plated
RoHS	compliant with exemption

## Specifications and approvals

IEC 61076-2-109

## Details

Other cable lengths on request!

Identification	Cable length	Part number Female	Drawing (dimensions in mm)
Circular connectors M12, Panel feed through, Pre-assembled on one side, EtherRail cable (4x 2x AWG 24/7), for rear mounting, Shielded	0.3 m	21 33 070 0853 003	
	0.5 m	21 33 070 0853 005	
	1 m	21 33 070 0853 010	
	1.5 m	21 33 070 0853 015	
	Circular connectors M12, Panel feed through, Pre-assembled on one side, Industrial Ethernet cable (4x 2x AWG 26/7), for rear mounting, Shielded	0.3 m	
0.5 m		21 33 080 0850 005	
1 m		21 33 080 0850 010	
1.5 m		21 33 080 0850 015	

Number of contacts

**4+**

Shielded

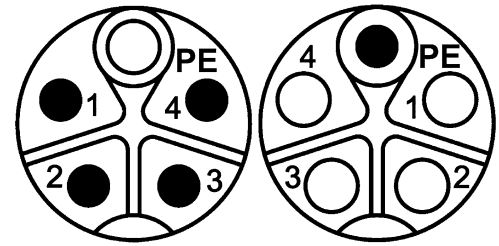

## Technical characteristics

Number of contacts	4
Rated current	12 A
Rated voltage	630 V
Rated impulse voltage	6 kV
Pollution degree	3
Insulation resistance	>10 <sup>8</sup> Ω
Contact resistance	≤10 mΩ
Mating cycles	≥100
Locking type	Screw locking, PushPull
Conductor length	30 cm
Degree of protection acc. to IEC 60529	IP65 / IP67, when mated

## Technical characteristics

Conductor cross-section	2.5 mm <sup>2</sup> , 1.5 mm <sup>2</sup>
Tightening torque	0.6 Nm, 2 Nm Lock nut
Material (insert)	Polyamide (PA)
Material (contacts)	Brass
Surface (contacts)	Gold plated

## Specifications and approvals

IEC 61076-2-111

Identification	Conductor cross-section (mm <sup>2</sup> )	Part number		Drawing (dimensions in mm)
		Male	Female	
Circular connectors M12, Power, Panel feed through, With conductors, for front mounting, Shielded 	1.5 2.5	21 03 309 5503 21 03 309 5501	21 03 309 6503 21 03 309 6501	<p>Panel cut out</p> <p>Panel cut out</p> <p>Panel cut out</p>
Circular connectors M12, Power, Panel feed through, With conductors, for rear mounting, Shielded 	1.5 2.5	21 03 309 5504 21 03 309 5502	21 03 309 6504 21 03 309 6502	<p>Panel cut out</p> <p>Panel cut out</p> <p>Panel cut out</p>

D03  
12  
·  
94

Number of contacts

# 4

Unshielded

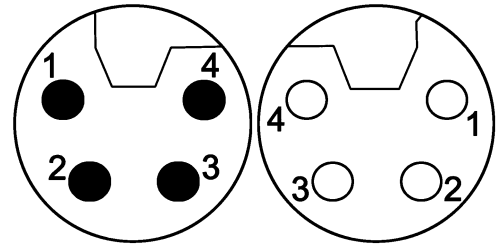

M12

## Technical characteristics

Number of contacts	4
Rated current	16 A
Rated voltage	63 V
Rated impulse voltage	1.5 kV
Pollution degree	3
Insulation resistance	>10 <sup>8</sup> Ω
Contact resistance	≤10 mΩ
Mating cycles	≥100
Locking type	Screw locking
Conductor length	30 cm
Degree of protection acc. to IEC 60529	IP65 / IP67, when mated
Conductor cross-section	1.5 mm <sup>2</sup> , 2.5 mm <sup>2</sup>
Conductor cross-section	AWG 16, AWG 14
Tightening torque	2 Nm Lock nut
Material (insert)	Polyamide (PA)

## Technical characteristics

Colour (insert)	Black
Material (hood/housing)	Zinc die-cast
Material (contacts)	Copper alloy
Surface (contacts)	Gold plated
RoHS	compliant with exemption

## Specifications and approvals

IEC 61076-2-111  
 UL 2238 CYJV2.E302521  
 CSA-C22.2 No. 182.3 CYJV8.E302521

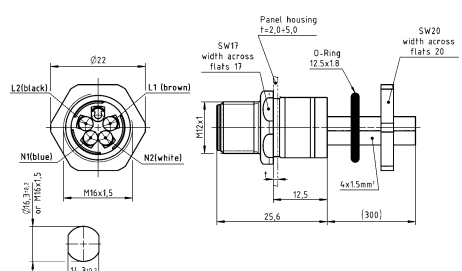
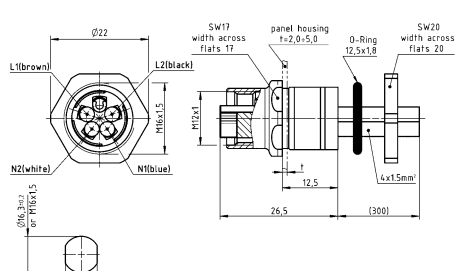

Identification	Conductor cross-section (mm <sup>2</sup> )	Part number		Drawing (dimensions in mm)
		Male	Female	
Circular connectors M12, Power, Panel feed through, With conductors, for front mounting, Unshielded 	1.5 2.5	21 03 596 1506	21 03 596 2506	 <p>Panel cut out</p>  <p>Panel cut out</p>
		21 03 599 1506	21 03 599 2506	

M12

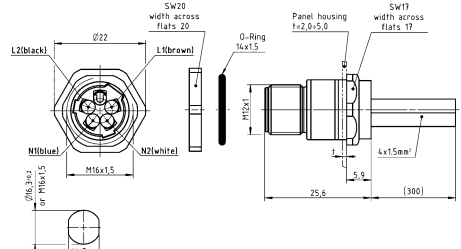
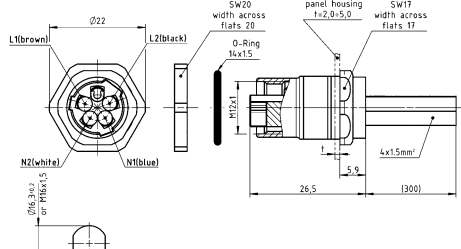
Identification	Conductor cross-section (mm <sup>2</sup> )	Part number		Drawing (dimensions in mm)
		Male	Female	
Circular connectors M12, Power, Panel feed through, With conductors, for rear mounting, Unshielded  	1.5 2.5	21 03 596 1516 21 03 599 1516	21 03 596 2516 21 03 599 2516	 <p>Panel cut out</p>  <p>Panel cut out</p>

Number of contacts

**4+**

Unshielded

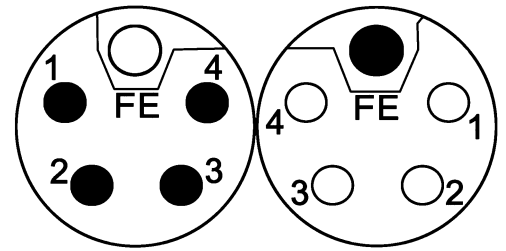

M12

## Technical characteristics

Number of contacts	4
Rated current	16 A
Rated voltage	63 V
Rated impulse voltage	1.5 kV
Pollution degree	3
Insulation resistance	>10 <sup>8</sup> Ω
Contact resistance	≤10 mΩ
Mating cycles	≥100
Locking type	Screw locking
Conductor length	30 cm
Degree of protection acc. to IEC 60529	IP65 / IP67, when mated
Conductor cross-section	1.5 mm <sup>2</sup> , 2.5 mm <sup>2</sup>
Conductor cross-section	AWG 16, AWG 14
Tightening torque	2 Nm Lock nut
Material (insert)	Polyamide (PA)

## Technical characteristics

Colour (insert)	Grey
Material (hood/housing)	Zinc die-cast
Material (contacts)	Copper alloy
Surface (contacts)	Gold plated
RoHS	compliant with exemption

## Specifications and approvals

IEC 61076-2-111  
 UL 2238 CYJV2.E302521  
 CSA-C22.2 No. 182.3 CYJV8.E302521



Identification	Conductor cross-section (mm <sup>2</sup> )	Part number		Drawing (dimensions in mm)
		Male	Female	
Circular connectors M12, Power, Panel feed through, With conductors, for front mounting, Unshielded	1.5	21 03 596 1505	21 03 596 2505	<p>Panel cut out</p> <p>Panel cut out</p>
	2.5	21 03 599 1505	21 03 599 2505	
Circular connectors M12, Power, Panel feed through, With conductors, for rear mounting, Unshielded	1.5	21 03 596 1515	21 03 596 2515	
	2.5	21 03 599 1515	21 03 599 2515	

Number of contacts

# 3+

Unshielded

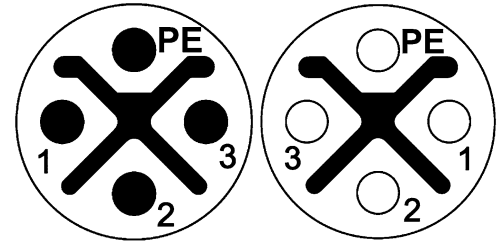

## Technical characteristics

Number of contacts	3
Rated current	12 A
Rated voltage	630 V
Rated impulse voltage	6 kV
Pollution degree	3
Insulation resistance	>10 <sup>8</sup> Ω
Contact resistance	≤10 mΩ
Mating cycles	≥100
Locking type	Screw locking, PushPull
Degree of protection acc. to IEC 60529	IP65 / IP67, when mated

## Technical characteristics

Conductor cross-section	1.5 mm <sup>2</sup> , 2.5 mm <sup>2</sup>
Conductor cross-section	AWG 16, AWG 14
Tightening torque	0.6 Nm, 2 Nm Lock nut
Material (insert)	Polyamide (PA)
Material (contacts)	Brass
Surface (contacts)	Gold plated

## Specifications and approvals

IEC 61076-2-111

Identification	Conductor cross-section (mm <sup>2</sup> )	Part number		Drawing (dimensions in mm)
		Male	Female	
Circular connectors M12, Power, Panel feed through, With conductors, for front mounting, Unshielded  	1.5	21 03 396 1401	21 03 396 2401	<p>Panel cut out</p> <p>Panel cut out</p> <p>Panel cut out</p>
	2.5	21 03 399 1401	21 03 399 2401	

D03  
12  
-  
98

Identification	Conductor cross-section (mm <sup>2</sup> )	Part number		Drawing (dimensions in mm)
		Male	Female	
Circular connectors M12, Power, Panel feed through, With conductors, for rear mounting, Unshielded	1.5	21 03 396 1402	21 03 396 2402	<p>Panel cut out</p> <p>Panel cut out</p> <p>Panel cut out</p>
	2.5	21 03 399 1402	21 03 399 2402	





M12

D03  
12  
-  
99

M12

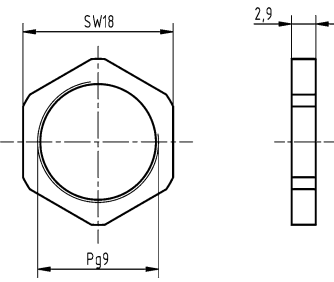
## Technical characteristics

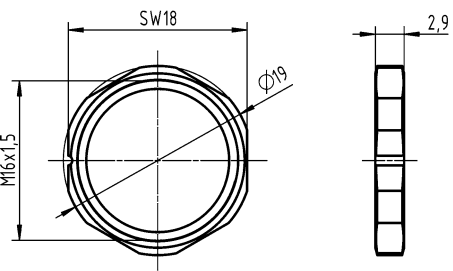
RoHS compliant with exemption, compliant

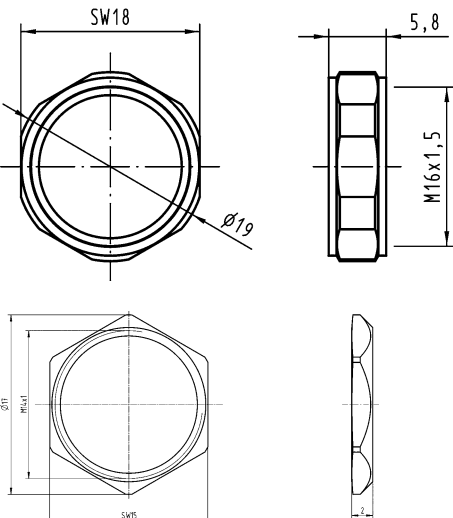
Identification	Part number	Drawing (dimensions in mm)
Lock nut, Pg 9 	21 01 000 0008	
Lock nut, M16x1.5 	21 01 000 0010 21 01 000 0018	
Lock nut, M14 x 1 	21 41 000 0011	





D03  
12  
·  
100

## Technical characteristics

Degree of protection acc. to IEC IP65 / IP67, IP67  
60529

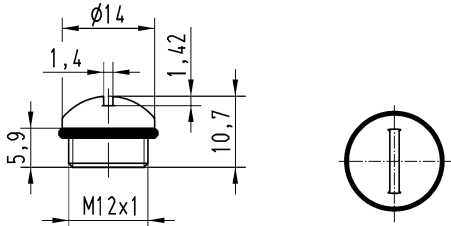
## Technical characteristics

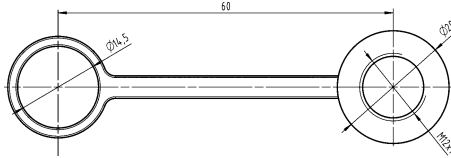
Material (accessories) Thermoplastic  
Colour (accessories) Black  
RoHS compliant

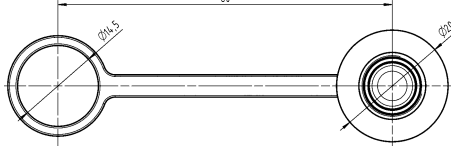
Identification	Part number	Drawing (dimensions in mm)
<p>Circular connectors M12, Cap, IP65 / IP67</p> 	<p>21 01 000 0003</p>	
<p>Circular connectors M12, Cap, for male inserts, with cord, IP67</p> 	<p>21 41 000 0001</p>	
<p>Circular connectors M12, Cap, for female inserts, with cord, IP67</p> 	<p>21 41 000 0002</p>	

M12







## Technical characteristics

Degree of protection acc. to IEC IP65 / IP67  
60529

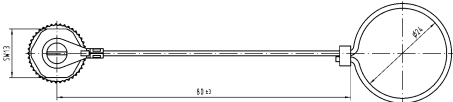
## Technical characteristics

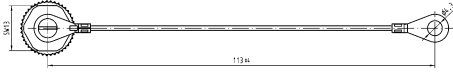
Material (accessories)  
RoHS

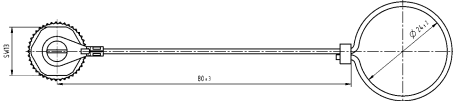
Metal  
compliant with exemption

Identification	Part number	Drawing (dimensions in mm)
Circular connectors M12, Cap, for female inserts, with cord  	21 01 000 0030	
Circular connectors M12, Cap, for female inserts, with cable clip  	21 01 000 0031	
Circular connectors M12, Cap, for male inserts, with cord  	21 01 000 0033	
Circular connectors M12, Cap, for male inserts, with cable clip  	21 01 000 0038	

Contents	Page
M23 Signal inserts .....	<b>D03 23.2</b>
M23 Signal contacts .....	<b>D03 23.22</b>
M23 Signal Hoods/Housings .....	<b>D03 23.23</b>
M23 Power inserts.....	<b>D03 23.28</b>
M23 Power contacts .....	<b>D03 23.33</b>
M23 Power Hoods/Housings .....	<b>D03 23.34</b>

Number of contacts

# 6

Crimp termination

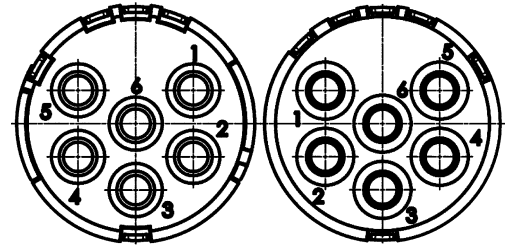

## Technical characteristics

Number of contacts	6
Rated current	20 A
Rated voltage	300 V
Rated impulse voltage	2.5 kV
Pollution degree	3
Insulation resistance	>10 <sup>10</sup> Ω
Limiting temperature	-40 ... +125 °C
Mating cycles	≥500
Conductor cross-section	0.75 ... 2.5 mm <sup>2</sup>
Material (insert)	Polyamide (PA)

## Technical characteristics

Colour (insert)	White
Material flammability class acc. to UL 94	V-0
RoHS	compliant

## Specifications and approvals

UL 1977 ECBT2.E235076

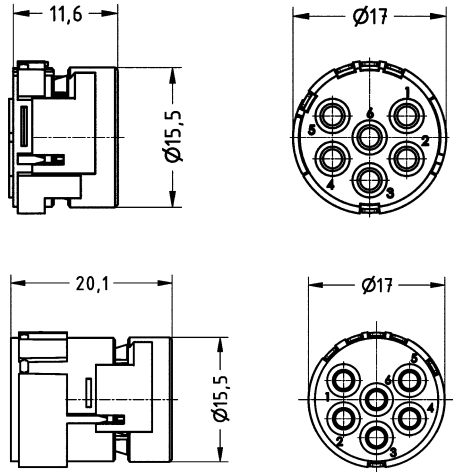
Identification	Conductor cross-section (mm <sup>2</sup> )	Part number		Drawing (dimensions in mm)
		Male	Female	
Circular connectors M23, Signal, Inserts, Crimp termination  Please order crimp contacts separately. 6x 2 mm	0.75 ... 2.5	09 15 106 3001	09 15 106 3101	

Number of contacts

# 6

Solder termination

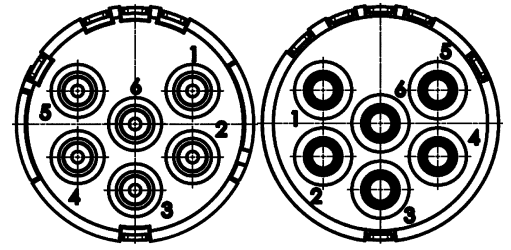

M23

## Technical characteristics

Number of contacts	6
Rated current	20 A
Rated voltage	300 V
Rated impulse voltage	2.5 kV
Pollution degree	3
Insulation resistance	$>10^{10} \Omega$
Limiting temperature	-40 ... +125 °C
Mating cycles	$\geq 500$
Conductor cross-section	2.5 mm <sup>2</sup> max.
Material (insert)	Polyamide (PA)
Colour (insert)	White

## Technical characteristics

Material (contacts)	Copper alloy
Surface (contacts)	Gold plated
Material flammability class acc. to UL 94	V-0
RoHS	compliant with exemption

## Specifications and approvals

UL 1977 ECBT2.E235076

Identification	Conductor cross-section (mm <sup>2</sup> )	Part number		Drawing (dimensions in mm)
		Male	Female	
Circular connectors M23, Signal, Inserts, Solder termination 	2.5 max.	09 15 106 2602	09 15 106 2702	

Number of contacts

# 6

PCB solder termination

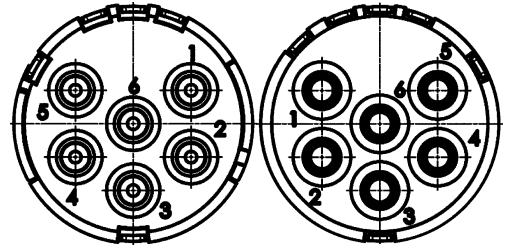

## Technical characteristics

Number of contacts	6
Rated current	20 A
Rated voltage	300 V
Rated impulse voltage	2.5 kV
Pollution degree	3
Insulation resistance	$>10^{10} \Omega$
Limiting temperature	-40 ... +125 °C
Mating cycles	$\geq 500$
Material (insert)	Polyamide (PA)
Colour (insert)	White

## Technical characteristics

Material (contacts)	Copper alloy
Surface (contacts)	Gold plated
Material flammability class acc. to UL 94	V-0
RoHS	compliant with exemption

## Specifications and approvals

UL 1977 ECBT2.E235076

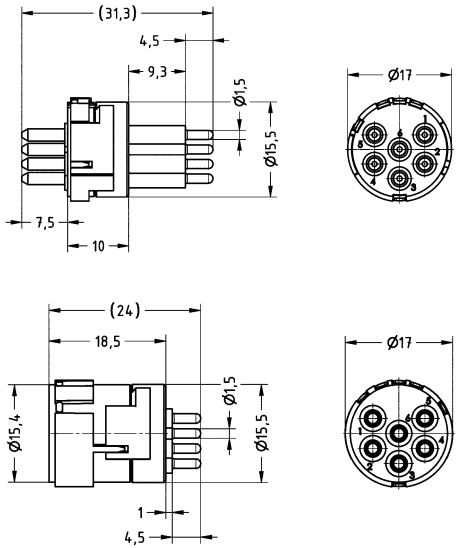
Identification	Part number		Drawing (dimensions in mm)
	Male	Female	
<p>Circular connectors M23, Signal, Inserts, PCB solder termination</p>  <p>Suitable for bulkhead mounted housings 09 15 100 0301, 0302, 0305, 0306 and 0307 only!</p>	09 15 106 2603	09 15 106 2703	

Number of contacts

# 7

Crimp termination

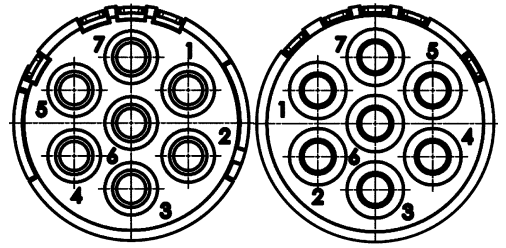

M23

## Technical characteristics

Number of contacts	7
Rated current	20 A
Rated voltage	300 V
Rated impulse voltage	2.5 kV
Pollution degree	3
Insulation resistance	$>10^{10} \Omega$
Limiting temperature	-40 ... +125 °C
Mating cycles	$\geq 500$
Conductor cross-section	0.75 ... 2.5 mm <sup>2</sup>
Material (insert)	Polyamide (PA)

## Technical characteristics

Colour (insert)	White
Material flammability class acc. to UL 94	V-0
RoHS	compliant with exemption

## Specifications and approvals

UL 1977 ECBT2.E235076

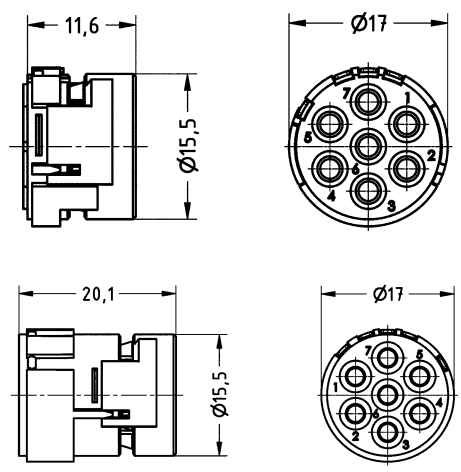
Identification	Conductor cross-section (mm <sup>2</sup> )	Part number		Drawing (dimensions in mm)
		Male	Female	
Circular connectors M23, Signal, Inserts, Crimp termination  Please order crimp contacts separately. 7x 2 mm	0.75 ... 2.5	09 15 107 3001	09 15 107 3101	

Number of contacts

# 7

Solder termination

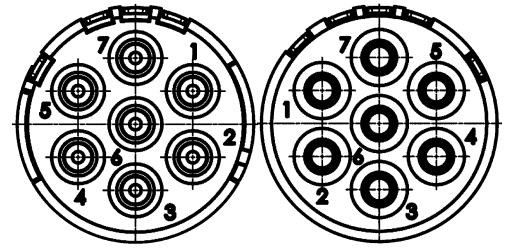

## Technical characteristics

Number of contacts	7
Rated current	20 A
Rated voltage	300 V
Rated impulse voltage	2.5 kV
Pollution degree	3
Insulation resistance	$>10^{10} \Omega$
Limiting temperature	-40 ... +125 °C
Mating cycles	$\geq 500$
Conductor cross-section	2.5 mm <sup>2</sup> max.
Material (insert)	Polyamide (PA)
Colour (insert)	White

## Technical characteristics

Material (contacts)	Copper alloy
Surface (contacts)	Gold plated
Material flammability class acc. to UL 94	V-0
RoHS	compliant with exemption

## Specifications and approvals

UL 1977 ECBT2.E235076

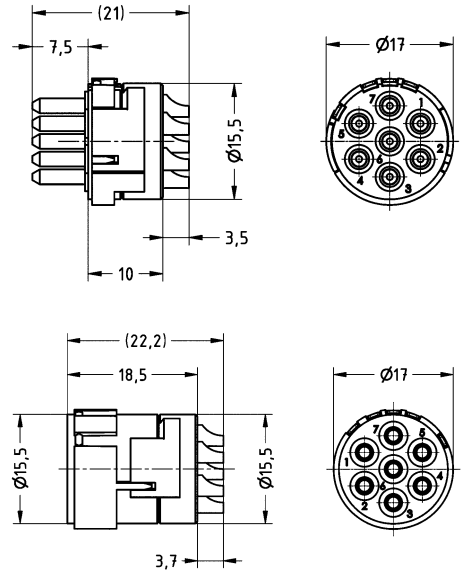
Identification	Conductor cross-section (mm <sup>2</sup> )	Part number		Drawing (dimensions in mm)
		Male	Female	
Circular connectors M23, Signal, Inserts, Solder termination 	2.5 max.	09 15 107 2602	09 15 107 2702	

Number of contacts

# 7

PCB solder termination

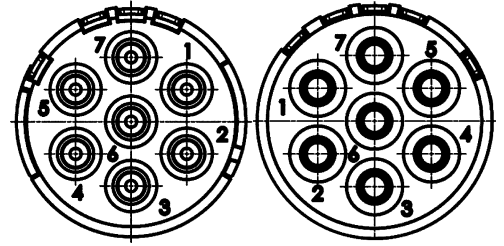

M23

## Technical characteristics

Number of contacts	7
Rated current	20 A
Rated voltage	300 V
Rated impulse voltage	2.5 kV
Pollution degree	3
Insulation resistance	$>10^{10} \Omega$
Limiting temperature	-40 ... +125 °C
Mating cycles	$\geq 500$
Material (insert)	Polyamide (PA)
Colour (insert)	White

## Technical characteristics

Material (contacts)	Copper alloy
Surface (contacts)	Gold plated
Material flammability class acc. to UL 94	V-0
RoHS	compliant with exemption

## Specifications and approvals

UL 1977 ECBT2.E235076

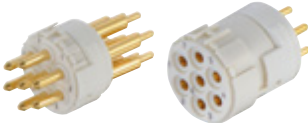
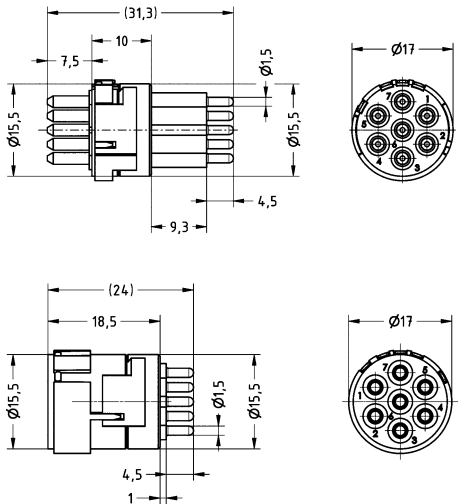
Identification	Part number		Drawing (dimensions in mm)
	Male	Female	
<p>Circular connectors M23, Signal, Inserts, PCB solder termination</p>  <p>Suitable for bulkhead mounted housings 09 15 100 0301, 0302, 0305, 0306 and 0307 only!</p>	09 15 107 2603	09 15 107 2703	

# M23 Signal inserts



Number of contacts

# 8

+ 1 additional special contact  
Crimp termination

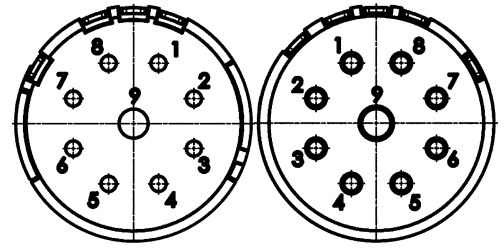

## Technical characteristics

Number of contacts	8
Additional contacts	+ 1 additional special contact
Rated current	8 A
Rated voltage	200 V
Rated impulse voltage	2.5 kV
Pollution degree	3
Rated current (special contact)	20 A
Rated voltage (special contact)	200 V
Rated impulse voltage (special contact)	2.5 kV
Pollution degree (special contact)	3
Insulation resistance	$>10^{10} \Omega$

## Technical characteristics

Limiting temperature	-40 ... +125 °C
Mating cycles	$\geq 500$
Conductor cross-section	0.08 ... 1.5 mm <sup>2</sup>
Material (insert)	Polyamide (PA)
Colour (insert)	White
Material flammability class acc. to UL 94	V-0
RoHS	compliant with exemption

## Specifications and approvals

UL 1977 ECBT2.E235076

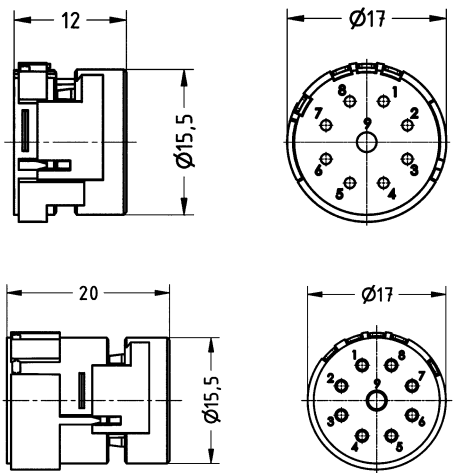
Identification	Conductor cross-section (mm <sup>2</sup> )	Part number		Drawing (dimensions in mm)
		Male	Female	
Circular connectors M23, Signal, Inserts, Crimp termination    Please order crimp contacts separately. 8x 1 mm 1x 2 mm	0.08 ... 1.5	09 15 109 3001	09 15 109 3101	

Number of contacts

# 8

+ 1 additional special contact  
Solder termination

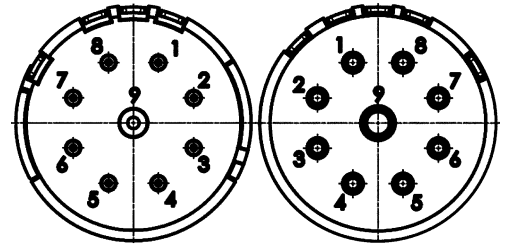

M23

## Technical characteristics

Number of contacts	8
Additional contacts	+ 1 additional special contact
Rated current	8 A
Rated voltage	200 V
Rated impulse voltage	2.5 kV
Pollution degree	3
Rated current (special contact)	20 A
Rated voltage (special contact)	200 V
Rated impulse voltage (special contact)	2.5 kV
Pollution degree (special contact)	3
Insulation resistance	>10 <sup>10</sup> Ω
Limiting temperature	-40 ... +125 °C

## Technical characteristics

Mating cycles	≥500
Conductor cross-section	1 mm <sup>2</sup> max.
Material (insert)	Polyamide (PA)
Colour (insert)	White
Material (contacts)	Copper alloy
Surface (contacts)	Gold plated
Material flammability class acc. to UL 94	V-0
RoHS	compliant with exemption

## Specifications and approvals

UL 1977 ECBT2.E235076

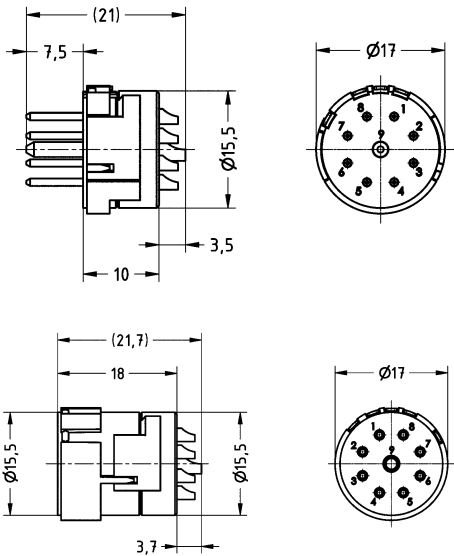
Identification	Conductor cross-section (mm <sup>2</sup> )	Part number		Drawing (dimensions in mm)
		Male	Female	
Circular connectors M23, Signal, Inserts, Solder termination 	1 max.	09 15 109 2602	09 15 109 2702	

# M23 Signal inserts



Number of contacts

# 8

+ 1 additional special contact  
PCB solder termination

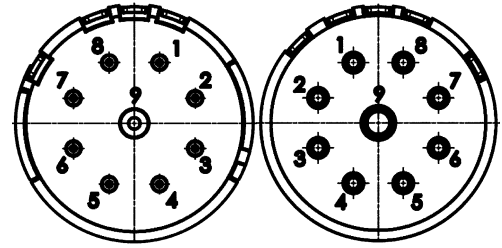

## Technical characteristics

Number of contacts	8
Additional contacts	+ 1 additional special contact
Rated current	8 A
Rated voltage	200 V
Rated impulse voltage	2.5 kV
Pollution degree	3
Rated current (special contact)	20 A
Rated voltage (special contact)	200 V
Rated impulse voltage (special contact)	2.5 kV
Pollution degree (special contact)	3
Insulation resistance	>10 <sup>10</sup> Ω
Limiting temperature	-40 ... +125 °C

## Technical characteristics

Mating cycles	≥500
Material (insert)	Polyamide (PA)
Colour (insert)	White
Material (contacts)	Copper alloy
Surface (contacts)	Gold plated
Material flammability class acc. to UL 94	V-0
RoHS	compliant with exemption

## Specifications and approvals

UL 1977 ECBT2.E235076

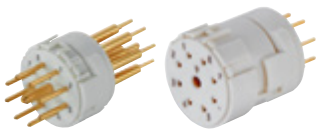
Identification	Part number		Drawing (dimensions in mm)
	Male	Female	
<p>Circular connectors M23, Signal, Inserts, PCB solder termination</p>  <p>Suitable for bulkhead mounted housings 09 15 100 0301, 0302, 0305, 0306 and 0307 only!</p>	09 15 109 2603	09 15 109 2703	

Number of contacts

**11+**

Crimp termination

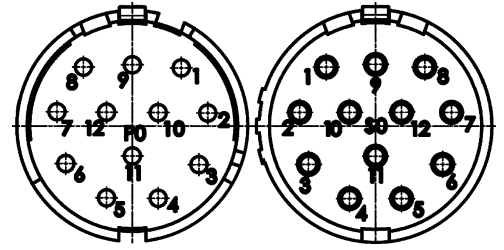

M23

## Technical characteristics

Number of contacts	11
Rated current	8 A
Rated voltage	200 V
Rated impulse voltage	2.5 kV
Pollution degree	3
Insulation resistance	$>10^{10} \Omega$
Limiting temperature	-40 ... +125 °C
Mating cycles	$\geq 500$
Conductor cross-section	0.08 ... 1.5 mm <sup>2</sup>
Material (insert)	Polyamide (PA)

## Technical characteristics

Colour (insert)	Grey
Material flammability class acc. to UL 94	V-0
RoHS	compliant with exemption

## Specifications and approvals

UL 1977 ECBT2.E235076

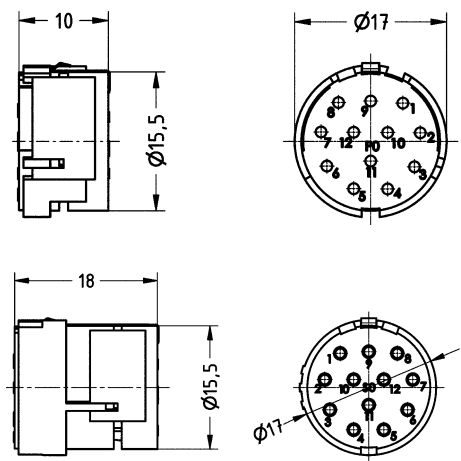
Identification	Conductor cross-section (mm <sup>2</sup> )	Part number		Drawing (dimensions in mm)
		Male	Female	
Circular connectors M23, Signal, Inserts, Crimp termination  Please order crimp contacts separately. 12x 1 mm	0.08 ... 1.5	09 15 112 3021	09 15 112 3121	

Number of contacts

**11+**

Solder termination

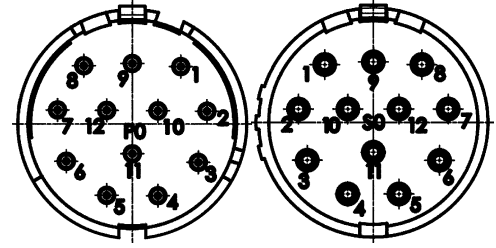

## Technical characteristics

Number of contacts	11
Rated current	8 A
Rated voltage	200 V
Rated impulse voltage	2.5 kV
Pollution degree	3
Insulation resistance	$>10^{10} \Omega$
Limiting temperature	-40 ... +125 °C
Mating cycles	$\geq 500$
Conductor cross-section	1 mm <sup>2</sup> max.
Material (insert)	Polyamide (PA)
Colour (insert)	Grey

## Technical characteristics

Material (contacts)	Copper alloy
Surface (contacts)	Gold plated
Material flammability class acc. to UL 94	V-0
RoHS	compliant with exemption

## Specifications and approvals

UL 1977 ECBT2.E235076

Identification	Conductor cross-section (mm <sup>2</sup> )	Part number		Drawing (dimensions in mm)
		Male	Female	
Circular connectors M23, Signal, Inserts, Solder termination 	1 max.	09 15 112 2622	09 15 112 2722	

Number of contacts

# 12

Crimp termination

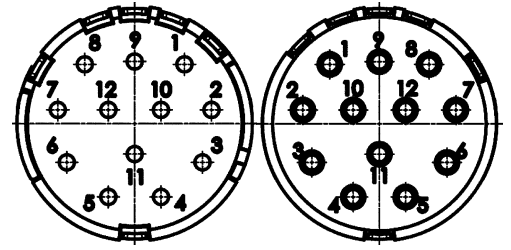

M23

## Technical characteristics

Number of contacts	12
Rated current	8 A
Rated voltage	200 V
Rated impulse voltage	2.5 kV
Pollution degree	3
Insulation resistance	$>10^{10} \Omega$
Limiting temperature	-40 ... +125 °C
Mating cycles	$\geq 500$
Conductor cross-section	0.08 ... 1.5 mm <sup>2</sup>
Material (insert)	Polyamide (PA)

## Technical characteristics

Colour (insert)	White
Material flammability class acc. to UL 94	V-0
RoHS	compliant with exemption, compliant

## Specifications and approvals

UL 1977 ECBT2.E235076

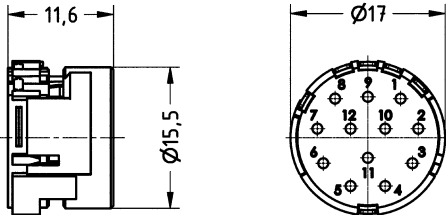
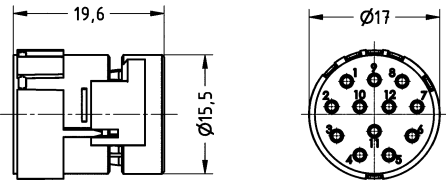
Identification	Conductor cross-section (mm <sup>2</sup> )	Part number		Drawing (dimensions in mm)
		Male	Female	
Circular connectors M23, Signal, Inserts, Crimp termination  Please order crimp contacts separately. 12x 1 mm	0.08 ... 1.5	09 15 112 3001	09 15 112 3101	 
Circular connectors M23, Signal, Inserts, Marking in opposite direction, Crimp termination Please order crimp contacts separately. 12x 1 mm	0.08 ... 1.5	09 15 112 3011	09 15 112 3111	

Number of contacts

# 12

Solder termination

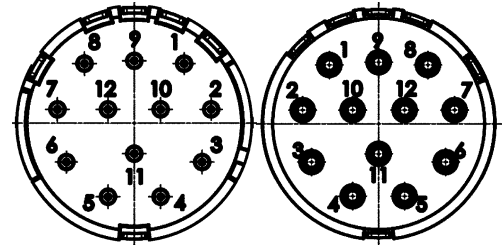

## Technical characteristics

Number of contacts	12
Rated current	8 A
Rated voltage	200 V
Rated impulse voltage	2.5 kV
Pollution degree	3
Insulation resistance	$>10^{10} \Omega$
Limiting temperature	-40 ... +125 °C
Mating cycles	$\geq 500$
Conductor cross-section	1 mm <sup>2</sup> max.
Material (insert)	Polyamide (PA)
Colour (insert)	White

## Technical characteristics

Material (contacts)	Copper alloy
Surface (contacts)	Gold plated
Material flammability class acc. to UL 94	V-0
RoHS	compliant with exemption, compliant

## Specifications and approvals

UL 1977 ECBT2.E235076

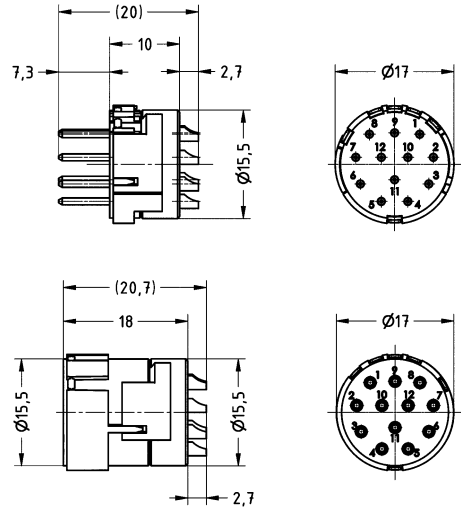
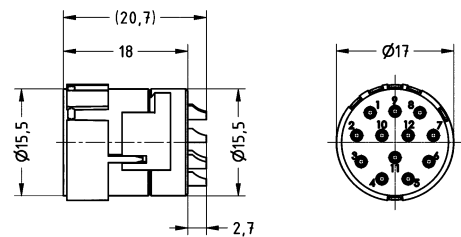
Identification	Conductor cross-section (mm <sup>2</sup> )	Part number		Drawing (dimensions in mm)
		Male	Female	
Circular connectors M23, Signal, Inserts, Solder termination 	1 max.	09 15 112 2602	09 15 112 2702	
Circular connectors M23, Signal, Inserts, Marking in opposite direction, Solder termination	1 max.	09 15 112 2612	09 15 112 2712	

Number of contacts

# 12

PCB solder termination

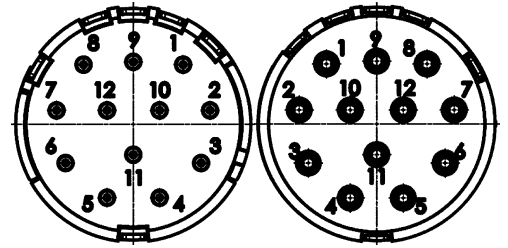

M23

## Technical characteristics

Number of contacts	12
Rated current	8 A
Rated voltage	200 V
Rated impulse voltage	2.5 kV
Pollution degree	3
Insulation resistance	$>10^{10} \Omega$
Limiting temperature	-40 ... +125 °C
Mating cycles	$\geq 500$
Material (insert)	Polyamide (PA)
Colour (insert)	White

## Technical characteristics

Material (contacts)	Copper alloy
Surface (contacts)	Gold plated
Material flammability class acc. to UL 94	V-0
RoHS	compliant with exemption

## Specifications and approvals

UL 1977 ECBT2.E235076

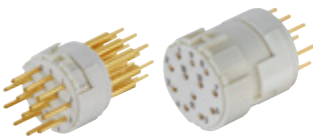
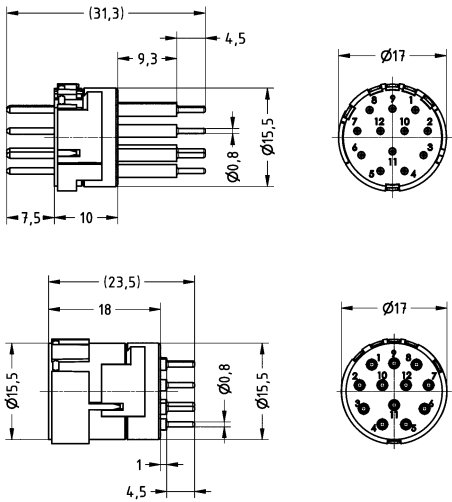
Identification	Part number		Drawing (dimensions in mm)
	Male	Female	
<p>Circular connectors M23, Signal, Inserts, PCB solder termination</p>  <p>Suitable for bulkhead mounted housings 09 15 100 0301, 0302, 0305, 0306 and 0307 only!</p>	09 15 112 2603	09 15 112 2703	

Number of contacts

# 17

Crimp termination

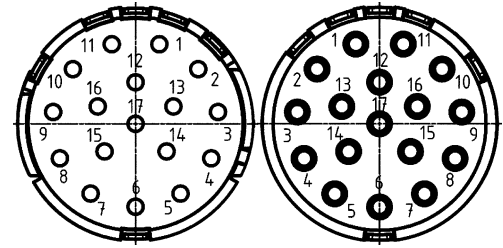

## Technical characteristics

Number of contacts	17
Rated current	8 A
Rated voltage	160 V
Rated impulse voltage	1.5 kV
Pollution degree	3
Insulation resistance	$>10^6 \Omega$
Limiting temperature	-40 ... +125 °C
Mating cycles	$\geq 500$
Conductor cross-section	0.08 ... 1.5 mm <sup>2</sup>
Material (insert)	Polyamide (PA)

## Technical characteristics

Colour (insert)	White
Material flammability class acc. to UL 94	V-0
RoHS	compliant with exemption

## Specifications and approvals

UL 1977 ECBT2.E235076

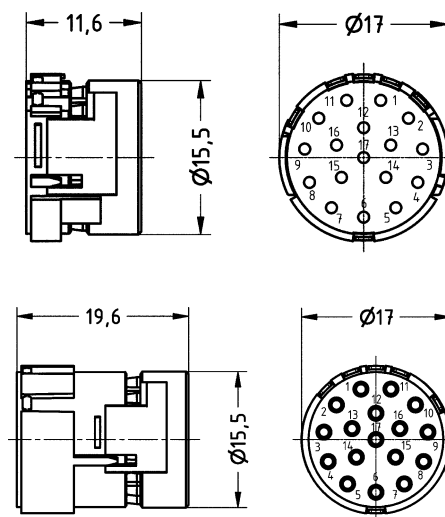
Identification	Conductor cross-section (mm <sup>2</sup> )	Part number		Drawing (dimensions in mm)
		Male	Female	
Circular connectors M23, Signal, Inserts, Crimp termination  Please order crimp contacts separately. 17x 1 mm	0.08 ... 1.5	09 15 117 3001	09 15 117 3101	

Number of contacts

# 17

Solder termination

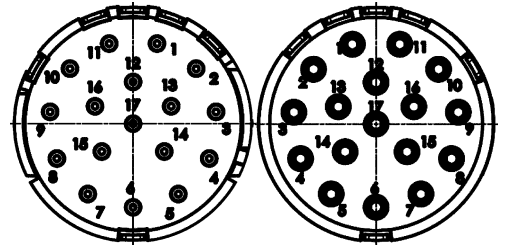

M23

## Technical characteristics

Number of contacts	17
Rated current	8 A
Rated voltage	160 V
Rated impulse voltage	1.5 kV
Pollution degree	3
Insulation resistance	>10 <sup>6</sup> Ω
Limiting temperature	-40 ... +125 °C
Mating cycles	≥500
Conductor cross-section	1 mm <sup>2</sup> max.
Material (insert)	Polyamide (PA)
Colour (insert)	White

## Technical characteristics

Material (contacts)	Copper alloy
Surface (contacts)	Gold plated
Material flammability class acc. to UL 94	V-0
RoHS	compliant with exemption

## Specifications and approvals

UL 1977 ECBT2.E235076

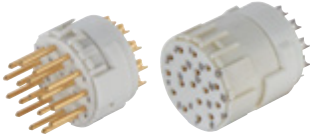
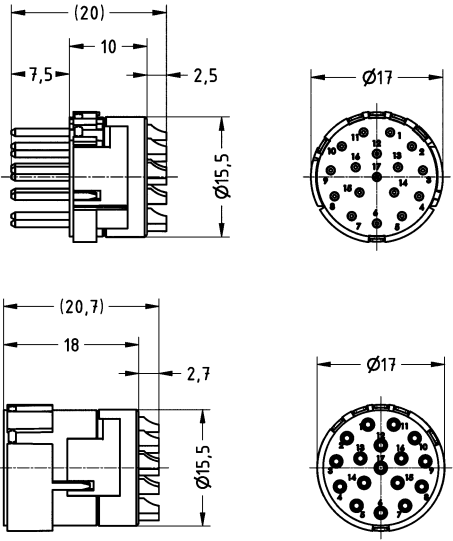
Identification	Conductor cross-section (mm <sup>2</sup> )	Part number		Drawing (dimensions in mm)
		Male	Female	
Circular connectors M23, Signal, Inserts, Solder termination 	1 max.	09 15 117 2602	09 15 117 2702	

Number of contacts

# 17

PCB solder termination

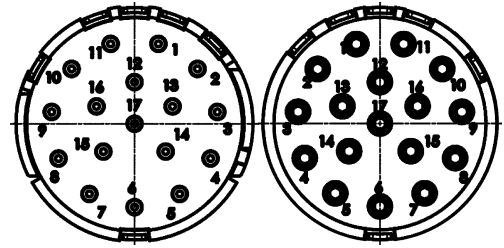

## Technical characteristics

Number of contacts	17
Rated current	8 A
Rated voltage	160 V
Rated impulse voltage	1.5 kV
Pollution degree	3
Insulation resistance	$>10^6 \Omega$
Limiting temperature	-40 ... +125 °C
Mating cycles	$\geq 500$
Material (insert)	Polyamide (PA)
Colour (insert)	White

## Technical characteristics

Material (contacts)	Copper alloy
Surface (contacts)	Gold plated
Material flammability class acc. to UL 94	V-0
RoHS	compliant with exemption

## Specifications and approvals

UL 1977 ECBT2.E235076

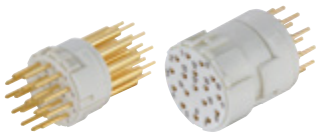
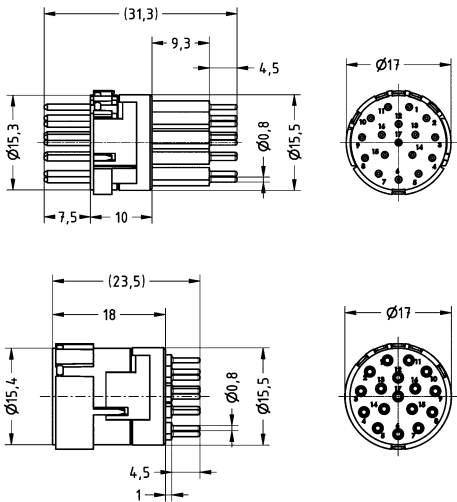
Identification	Part number		Drawing (dimensions in mm)
	Male	Female	
<p>Circular connectors M23, Signal, Inserts, PCB solder termination</p>  <p>Suitable for bulkhead mounted housings 09 15 100 0301, 0302, 0305, 0306 and 0307 only!</p>	09 15 117 2603	09 15 117 2703	

Number of contacts

# 16

+ 3 additional special contacts  
Crimp termination

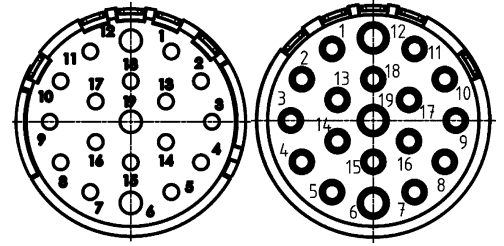

M23

## Technical characteristics

Number of contacts	16
Additional contacts	+ 3 additional special contacts
Rated current	8 A
Rated voltage	100 V
Rated impulse voltage	1.5 kV
Pollution degree	3
Rated current (special contact)	10 A
Rated voltage (special contact)	100 V
Rated impulse voltage (special contact)	1.5 kV
Pollution degree (special contact)	3
Insulation resistance	>10 <sup>6</sup> Ω

## Technical characteristics

Limiting temperature	-40 ... +125 °C
Mating cycles	≥500
Conductor cross-section	0.08 ... 1.5 mm <sup>2</sup>
Material (insert)	Polyamide (PA)
Colour (insert)	White
Material flammability class acc. to UL 94	V-0
RoHS	compliant with exemption

## Specifications and approvals

UL 1977 ECBT2.E235076

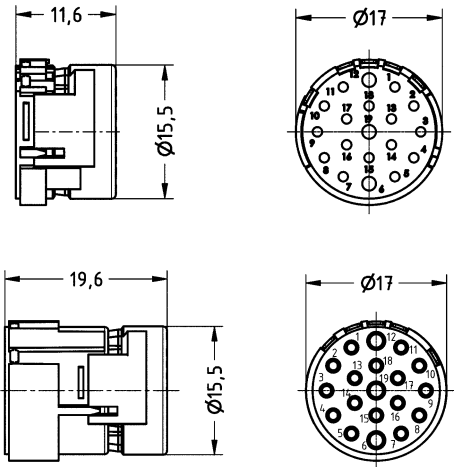
Identification	Conductor cross-section (mm <sup>2</sup> )	Part number		Drawing (dimensions in mm)
		Male	Female	
Circular connectors M23, Signal, Inserts, Crimp termination  Please order crimp contacts separately. 16x 1 mm 3x 1.5 mm	0.08 ... 1.5	09 15 119 3001	09 15 119 3101	

Number of contacts

# 16

+ 3 additional special contacts  
Solder termination

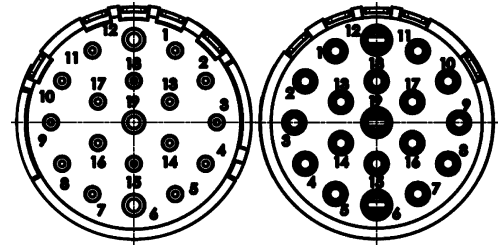

## Technical characteristics

Number of contacts	16
Additional contacts	+ 3 additional special contacts
Rated current	8 A
Rated voltage	100 V
Rated impulse voltage	1.5 kV
Pollution degree	3
Rated current (special contact)	10 A
Rated voltage (special contact)	100 V
Rated impulse voltage (special contact)	1.5 kV
Pollution degree (special contact)	3
Insulation resistance	>10 <sup>6</sup> Ω
Limiting temperature	-40 ... +125 °C

## Technical characteristics

Mating cycles	≥500
Conductor cross-section	1 mm <sup>2</sup> max.
Material (insert)	Polyamide (PA)
Colour (insert)	White
Material (contacts)	Copper alloy
Surface (contacts)	Gold plated
Material flammability class acc. to UL 94	V-0
RoHS	compliant with exemption

## Specifications and approvals

UL 1977 ECBT2.E235076

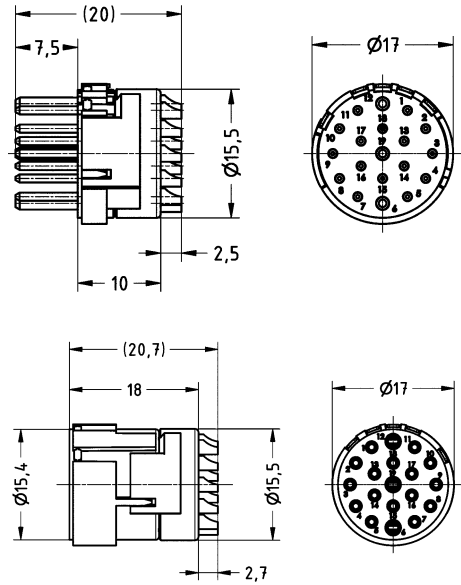
Identification	Conductor cross-section (mm <sup>2</sup> )	Part number		Drawing (dimensions in mm)
		Male	Female	
Circular connectors M23, Signal, Inserts, Solder termination 	1 max.	09 15 119 2602	09 15 119 2702	

Number of contacts

# 16

+ 3 additional special contacts  
PCB solder termination

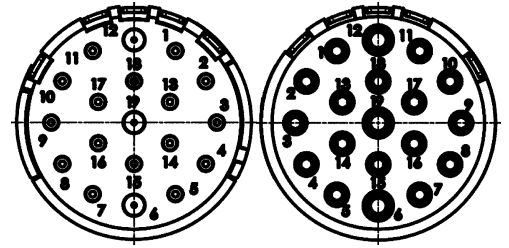

M23

## Technical characteristics

Number of contacts	16
Additional contacts	+ 3 additional special contacts
Rated current	8 A
Rated voltage	100 V
Rated impulse voltage	1.5 kV
Pollution degree	3
Rated current (special contact)	10 A
Rated voltage (special contact)	100 V
Rated impulse voltage (special contact)	1.5 kV
Pollution degree (special contact)	3
Insulation resistance	>10 <sup>6</sup> Ω
Limiting temperature	-40 ... +125 °C

## Technical characteristics

Mating cycles	≥500
Material (insert)	Polyamide (PA)
Colour (insert)	White
Material (contacts)	Copper alloy
Surface (contacts)	Gold plated
Material flammability class acc. to UL 94	V-0
RoHS	compliant with exemption

## Specifications and approvals

UL 1977 ECBT2.E235076

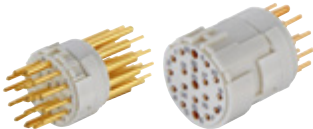
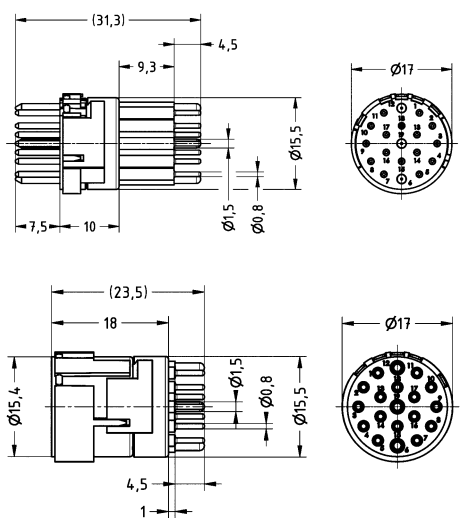
Identification	Part number		Drawing (dimensions in mm)
	Male	Female	
<p>Circular connectors M23, Signal, Inserts, PCB solder termination</p>  <p>Suitable for bulkhead mounted housings 09 15 100 0301, 0302, 0305, 0306 and 0307 only!</p>	09 15 119 2603	09 15 119 2703	

M23

## Technical characteristics





Contact resistance	≤3 mΩ
Conductor cross-section	0.08 ... 0.56 mm <sup>2</sup> , 0.14 ... 1 mm <sup>2</sup> , 0.75 ... 1.5 mm <sup>2</sup> , 0.75 ... 2.5 mm <sup>2</sup> , 0.34 ... 1 mm <sup>2</sup> , 0.14 ... 0.56 mm <sup>2</sup> , 0.56 ... 1 mm <sup>2</sup>
Conductor cross-section	AWG 28 ... AWG 20, AWG 26 ... AWG 17, AWG 19 ... AWG 16, AWG 19 ... AWG 14, AWG 22 ... AWG 17, AWG 26 ... AWG 20, AWG 20 ... AWG 17

## Technical characteristics

Material (contacts)	Copper alloy
Surface (contacts)	Gold plated
RoHS	compliant with exemption

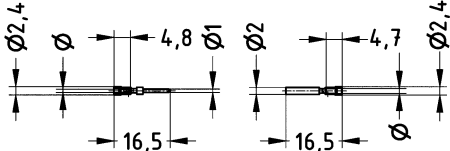
## Specifications and approvals

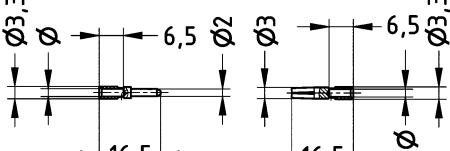
EN 60664-1  
IEC 61984

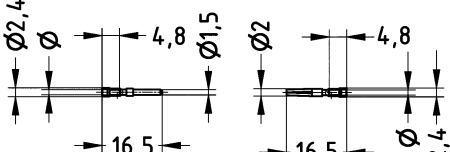
Identification	Conductor cross-section (mm <sup>2</sup> )	Part number		Drawing (dimensions in mm)
		Male	Female	
Circular connectors M23, Signal, Crimp contact, 1 mm, Turned contacts 	0.08 ... 0.56	09 15 100 6101	09 15 100 6201	 <p>Stripping length 4 mm</p>
	0.14 ... 1	09 15 100 6102	09 15 100 6202	
	0.34 ... 1	09 15 100 6103	09 15 100 6203	
	0.75 ... 1.5	09 15 100 6103	09 15 100 6203	
Circular connectors M23, Signal, Crimp contact, 2 mm, Turned contacts 	0.75 ... 2.5	09 15 100 6121	09 15 100 6221	 <p>Stripping length 4 mm</p>
Circular connectors M23, Signal, Crimp contact, 1.5 mm, Turned contacts 	0.14 ... 0.56	09 15 100 6111	09 15 100 6211	 <p>Stripping length 4 mm</p>
	0.14 ... 1 0.56 ... 1		09 15 100 6212	

D03  
23  
·  
22

## Technical characteristics



Limiting temperature	-40 ... +125 °C
Locking type	Screw locking, ComLock rapid locking
Degree of protection acc. to IEC 60529	IP67, in locked position, IP69 / IPX9K acc. to ISO 20653
Material (hood/housing)	Copper-zinc alloy
Surface (hood/housing)	Nickel plated
Material (seal)	NBR

## Technical characteristics

Colour (seal)	Black
RoHS	compliant with exemption, compliant

## Specifications and approvals

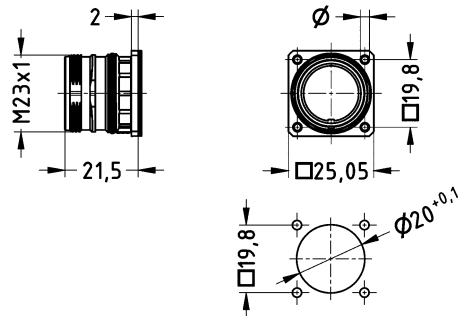





UL 1977 ECBT2.E235076



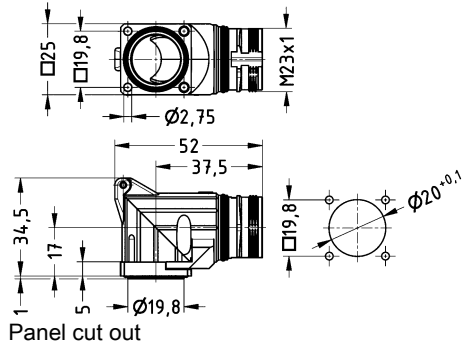

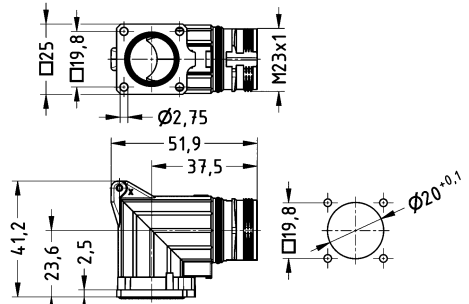

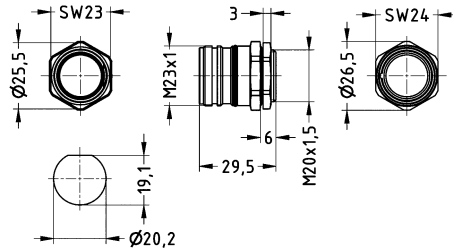
Identification	Clamping range (mm)	Part number	Drawing (dimensions in mm)
<p>Circular connectors M23, Signal, Bulkhead mounted housing, Front mounting, Fixing hole 4 x 2.7 mm</p> 		09 15 100 0301	 <p>Panel cut out</p>
<p>Circular connectors M23, Signal, Bulkhead mounted housing, Front mounting, Fixing hole 4 x 3.2 mm</p> 		09 15 100 0302	

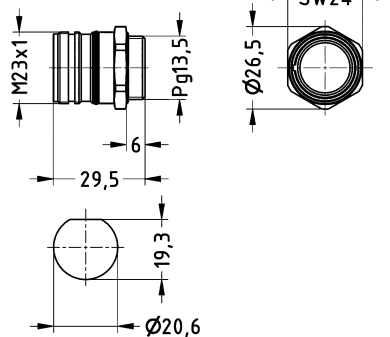
# M23 Signal Hoods/Housings

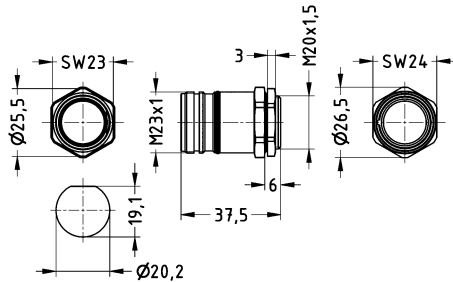

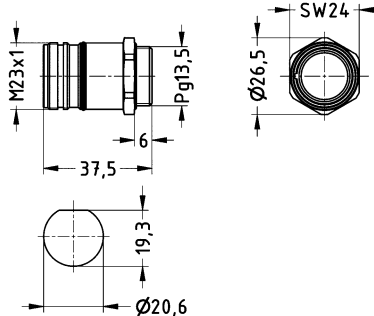
M23

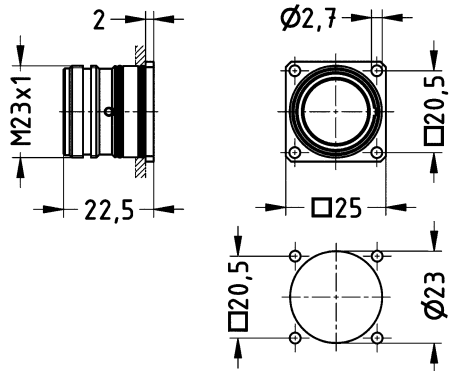

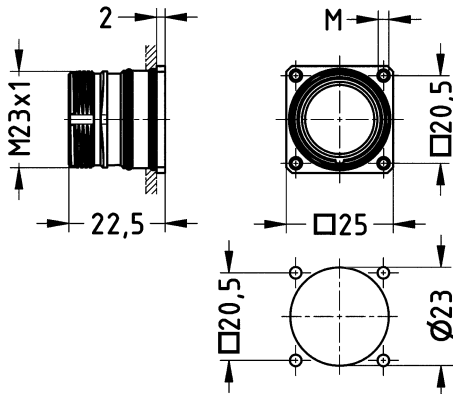
Identification	Clamping range (mm)	Part number	Drawing (dimensions in mm)
<p>Circular connectors M23, Signal, Bulkhead mounted housing, Front mounting, Angled, Fixing hole 4 x 2.7 mm</p> 		09 15 100 0901	 <p>Panel cut out</p>
<p>Circular connectors M23, Signal, Bulkhead mounted housing, Front mounting, Angled, Rotatable, Fixing hole 4 x 2.7 mm</p> 		09 15 100 0902	 <p>Panel cut out</p>
<p>Circular connectors M23, Signal, Bulkhead mounted housing, Front mounting, Thread M20 x 1.5</p>  <p>for male inserts Not compatible to ComLock</p>		09 15 100 0363	 <p>Panel cut out</p>
<p>Circular connectors M23, Signal, Bulkhead mounted housing, Front mounting, Thread Pg 13.5</p>  <p>for male inserts Not compatible to ComLock</p>		09 15 100 0364	 <p>Panel cut out</p>

Identification	Clamping range (mm)	Part number	Drawing (dimensions in mm)
<p>Circular connectors M23, Signal, Bulkhead mounted housing, Front mounting, Thread M20 x 1.5</p>  <p>for female inserts Not compatible to ComLock</p>		09 15 100 0373	 <p>Panel cut out</p>
<p>Circular connectors M23, Signal, Bulkhead mounted housing, Front mounting, Thread Pg 13.5</p>  <p>for female inserts Not compatible to ComLock</p>		09 15 100 0374	 <p>Panel cut out</p>
<p>Circular connectors M23, Signal, Bulkhead mounted housing, Rear mounting, Fixing hole 4 x 2.7 mm</p> 		09 15 100 0307	 <p>Panel cut out</p>
<p>Circular connectors M23, Signal, Bulkhead mounted housing, Rear mounting, Thread 4 x M2.5</p> 		09 15 100 0305	 <p>Panel cut out</p>

M23

D03  
23  
-  
25

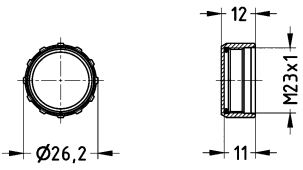

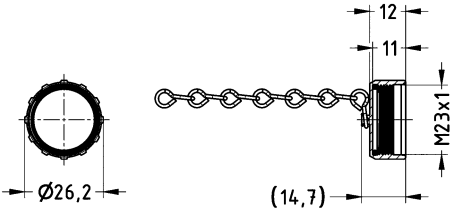
Identification	Clamping range (mm)	Part number	Drawing (dimensions in mm)
<p>Circular connectors M23, Signal, Cover, for bulkhead mounted housings, for cable to cable housing</p> 		09 15 100 9101	
<p>Circular connectors M23, Signal, Cover, for bulkhead mounted housings, for cable to cable housing, With chain (70 mm)</p> 		09 15 100 9102	

M23

Number of contacts

**5+**

Crimp termination

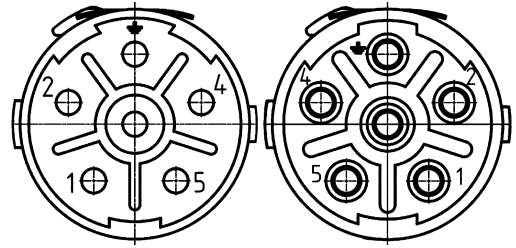

## Technical characteristics

Number of contacts	5
Rated current	28 A
Rated voltage	600 V
Rated impulse voltage	4 kV
Pollution degree	3
Insulation resistance	$>10^{13} \Omega$
Limiting temperature	-40 ... +125 °C
Mating cycles	$\geq 500$
Conductor cross-section	0.14 ... 4 mm <sup>2</sup>
Material (insert)	Polyamide (PA)

## Technical characteristics

Colour (insert)	Blue
Material flammability class acc. to UL 94	V-0
RoHS	compliant

## Specifications and approvals

UL 1977 ECBT2.E235076

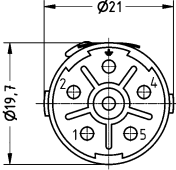
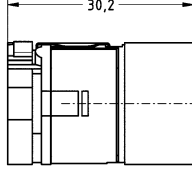
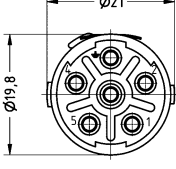
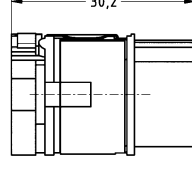
Identification	Conductor cross-section (mm <sup>2</sup> )	Part number		Drawing (dimensions in mm)	
		Male	Female		
Circular connectors M23, Power, Inserts, Crimp termination  Please order crimp contacts separately. 6x 2 mm	0.14 ... 4	09 15 606 3001	09 15 606 3101		
					

Number of contacts

**3+**

+ 4 additional signal contacts  
Crimp termination

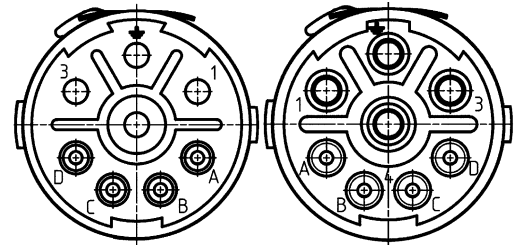

M23

## Technical characteristics

Number of contacts	3
Additional contacts	+ 4 additional signal contacts
Rated current	28 A
Rated voltage	600 V
Rated impulse voltage	4 kV
Pollution degree	3
Rated current (signal)	8 A
Rated voltage (signal)	300 V
Rated impulse voltage (signal)	2.5 kV
Pollution degree (signal)	3
Insulation resistance	>10 <sup>13</sup> Ω
Limiting temperature	-40 ... +125 °C

## Technical characteristics

Mating cycles	≥500
Conductor cross-section	0.14 ... 4 mm <sup>2</sup>
Material (insert)	Polyamide (PA)
Colour (insert)	Blue
Material flammability class acc. to UL 94	V-0
RoHS	compliant

## Specifications and approvals

UL 1977 ECBT2.E235076

Identification	Conductor cross-section (mm <sup>2</sup> )	Part number		Drawing (dimensions in mm)
		Male	Female	
<p>Circular connectors M23, Power, Inserts, Crimp termination</p> <p>Please order crimp contacts separately. 4x 2 mm 4x 1 mm</p>	0.14 ... 4	09 15 608 3001	09 15 608 3101	

Number of contacts

**3+**

+ 5 additional signal contacts  
Crimp termination

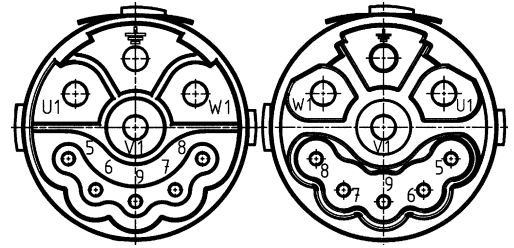

## Technical characteristics

Number of contacts	3
Additional contacts	+ 5 additional signal contacts
Rated current	28 A
Rated voltage	630 V
Rated impulse voltage	4 kV
Pollution degree	3
Rated current (signal)	10 A
Rated voltage (signal)	250 V
Rated impulse voltage (signal)	2.5 kV
Pollution degree (signal)	3
Insulation resistance	>10 <sup>13</sup> Ω
Limiting temperature	-40 ... +125 °C

## Technical characteristics

Mating cycles	≥500
Conductor cross-section	0.14 ... 4 mm <sup>2</sup>
Material (insert)	Polyamide (PA)
Colour (insert)	Blue
Material flammability class acc. to UL 94	V-0
RoHS	compliant

## Specifications and approvals

UL 1977 ECBT2.E235076

Identification	Conductor cross-section (mm <sup>2</sup> )	Part number		Drawing (dimensions in mm)
		Male	Female	
<p>Circular connectors M23, Power, Inserts, Mating face (A), Crimp termination</p> <p>Please order crimp contacts separately. 4x 2 mm 5x 1 mm</p>	0.14 ... 4	09 15 609 3001	09 15 609 3101	

Number of contacts

**3+**

+ 5 additional signal contacts  
Crimp termination

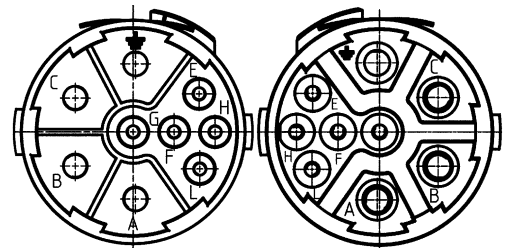

M23

## Technical characteristics

Number of contacts	3
Additional contacts	+ 5 additional signal contacts
Rated current	28 A
Rated voltage	630 V
Rated impulse voltage	4 kV
Pollution degree	3
Rated current (signal)	10 A
Rated voltage (signal)	250 V
Rated impulse voltage (signal)	2.5 kV
Pollution degree (signal)	3
Insulation resistance	>10 <sup>13</sup> Ω
Limiting temperature	-40 ... +125 °C

## Technical characteristics

Mating cycles	≥500
Conductor cross-section	0.14 ... 4 mm <sup>2</sup>
Material (insert)	Polyamide (PA)
Colour (insert)	Blue
Material flammability class acc. to UL 94	V-0
RoHS	compliant

## Specifications and approvals

UL 1977 ECBT2.E235076

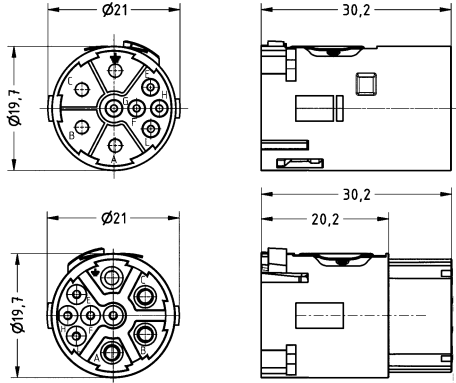
Identification	Conductor cross-section (mm <sup>2</sup> )	Part number		Drawing (dimensions in mm)
		Male	Female	
Circular connectors M23, Power, Inserts, Mating face (B), Crimp termination   Please order crimp contacts separately. 4x 2 mm 5x 1 mm	0.14 ... 4	09 15 609 3011	09 15 609 3111	

Number of contacts

**3+**

+ 4 additional signal contacts + 4 Data  
Crimp termination

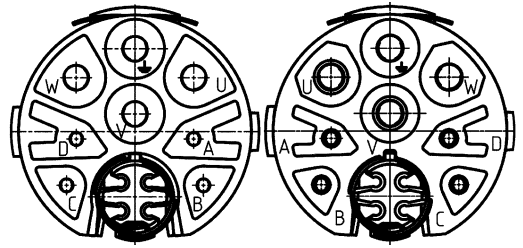

## Technical characteristics

Number of contacts	3
Additional contacts	+ 4 additional signal contacts, + 4 Data
Rated current	28 A
Rated voltage	630 V
Rated impulse voltage	4 kV
Pollution degree	3
Rated current (signal)	8 A
Rated voltage (signal)	300 V
Rated impulse voltage (signal)	2.5 kV
Pollution degree (signal)	3
Rated current (data)	2 A
Rated voltage (data)	60 V
Rated impulse voltage (data)	0.5 kV

## Technical characteristics

Pollution degree (data)	3
Limiting temperature	-40 ... +125 °C
Mating cycles	≥500
Conductor cross-section	0.08 ... 4 mm <sup>2</sup>
Material (insert)	Polyamide (PA)
Colour (insert)	Blue
Material flammability class acc. to UL 94	V-0
RoHS	compliant

## Specifications and approvals

UL 1977 ECBT2.E235076

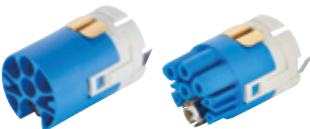
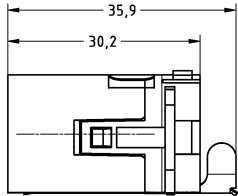
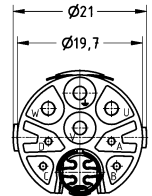
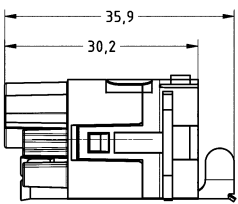
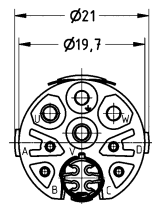



Identification	Conductor cross-section (mm <sup>2</sup> )	Part number		Drawing (dimensions in mm)	
		Male	Female		
Circular connectors M23, Hybrid, Inserts, Crimp termination   Please order crimp contacts separately. 4x 2 mm 4x 1 mm 4x 0.6 mm	0.08 ... 4	09 15 612 3001	09 15 612 3101		
					

## Technical characteristics

Contact resistance	≤3 mΩ
Conductor cross-section	0.08 ... 0.34 mm <sup>2</sup> , 0.14 ... 1 mm <sup>2</sup> , 0.75 ... 2.5 mm <sup>2</sup> , 2.5 ... 4 mm <sup>2</sup>
Material (contacts)	Copper alloy
Surface (contacts)	Gold plated
RoHS	compliant, compliant with exemption

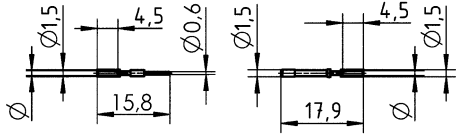
## Specifications and approvals

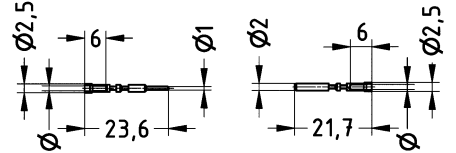
EN 60664-1  
IEC 61984

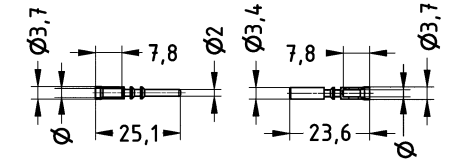
Identification	Conductor cross-section (mm <sup>2</sup> )	Part number		Drawing (dimensions in mm)
		Male	Female	
Circular connectors M23, Power, Crimp contact, 0.6 mm, Turned contacts 	0.08 ... 0.34	09 15 600 6191	09 15 600 6291	 Stripping length 4 mm
Circular connectors M23, Power, Crimp contact, 1 mm, Turned contacts 	0.14 ... 1	09 15 600 6101	09 15 600 6201	 Stripping length 4 mm
Circular connectors M23, Power, Crimp contact, 2 mm, Turned contacts 	0.75 ... 2.5 2.5 ... 4	09 15 600 6121 09 15 600 6122	09 15 600 6221 09 15 600 6222	 Stripping length 7 mm

M23

## Technical characteristics



Limiting temperature	-40 ... +125 °C
Locking type	Screw locking, ComLock rapid locking
Degree of protection acc. to IEC 60529	IP67 / IP69 / IPX9K acc. to ISO 20653, in locked position
Material (hood/housing)	Copper-zinc alloy
Surface (hood/housing)	Nickel plated
Material (seal)	NBR



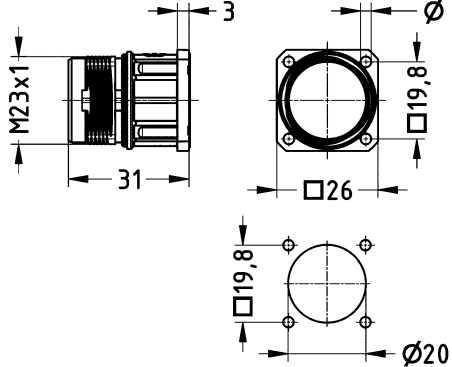

## Technical characteristics

Colour (seal)	Black
RoHS	compliant, compliant with exemption

## Specifications and approvals

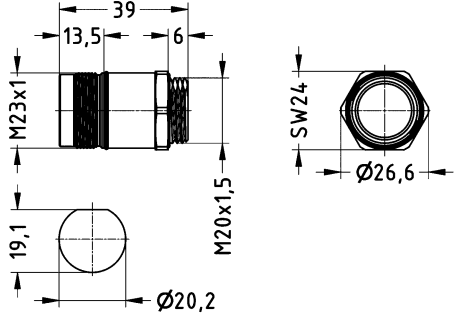
UL 1977 ECBT2.E235076

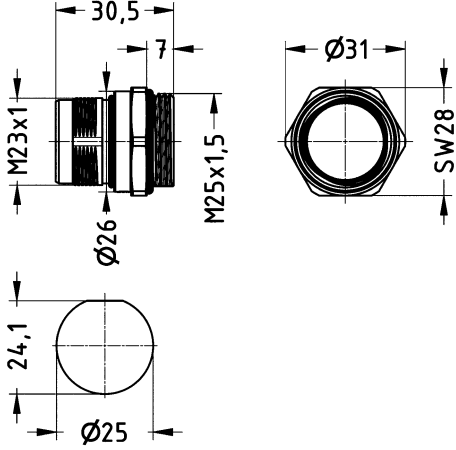
Identification	Clamping range (mm)	Part number	Drawing (dimensions in mm)
<p>Circular connectors M23, Power, Bulkhead mounted housing, Straight, Front mounting, Fixing hole 4 x 2.7 mm</p> 		09 15 600 0301	 <p>Panel cut out</p>
<p>Circular connectors M23, Power, Bulkhead mounted housing, Straight, Front mounting, Fixing hole 4 x 3.2 mm</p> 		09 15 600 0302	

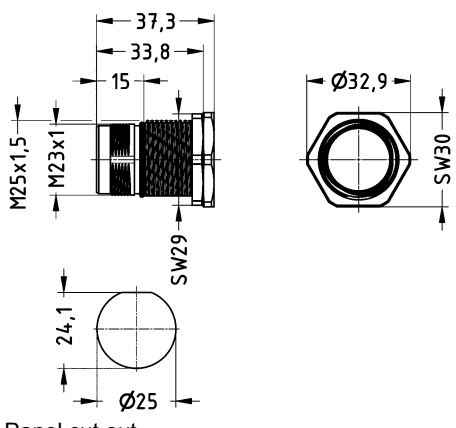





Identification	Clamping range (mm)	Part number	Drawing (dimensions in mm)
<p>Circular connectors M23, Power, Bulkhead mounted housing, Straight, Front mounting, Thread M20 x 1.5</p>  <p>Not compatible to ComLock</p>		09 15 600 0303	 <p>Panel cut out</p>
<p>Circular connectors M23, Power, Bulkhead mounted housing, Straight, Front mounting, Thread M25 x 1.5</p> 		09 15 600 0313	 <p>Panel cut out</p>
<p>Circular connectors M23, Power, Bulkhead mounted housing, Straight, Rear mounting, Thread M25 x 1.5</p> 		09 15 600 0308	 <p>Panel cut out</p>

M23

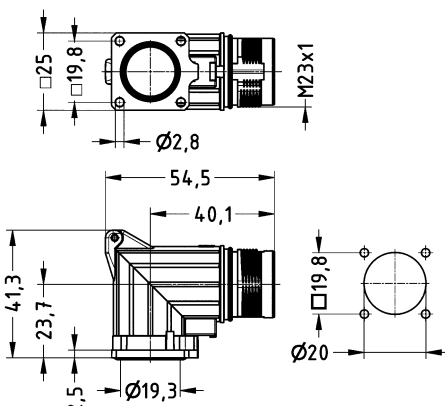
# M23 Power Hoods/Housings

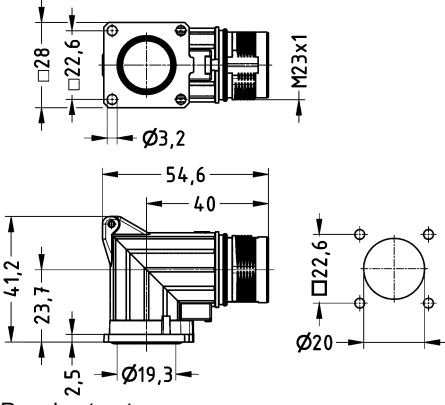

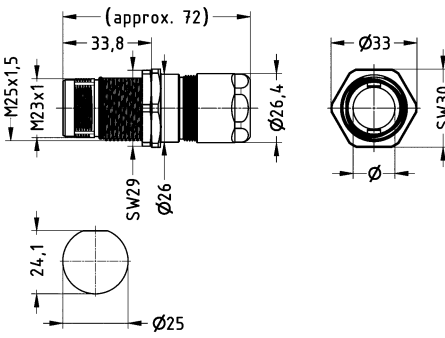
M23

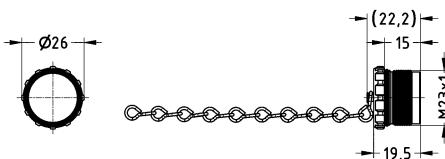
Identification	Clamping range (mm)	Part number	Drawing (dimensions in mm)
<p>Circular connectors M23, Power, Bulkhead mounted housing, Angled, Rotatable, Fixing hole 4 x 2.7 mm</p> 		09 15 600 0902	 <p>Panel cut out</p>
<p>Circular connectors M23, Power, Bulkhead mounted housing, Angled, Rotatable, Fixing hole 4 x 3.2 mm</p> 		09 15 600 0912	 <p>Panel cut out</p>
<p>Circular connectors M23, Power, Panel feed through housing, Rear mounting, EMC version</p> 	7 ... 12 11 ... 17	09 15 600 0310 09 15 600 0311	 <p>Panel cut out</p>
<p>Circular connectors M23, Power, Cover, for hoods, With chain (100 mm)</p>  <p>Not compatible to ComLock</p>		09 15 600 9103	

D03  
23  
·  
36

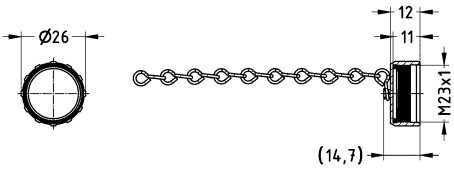
Identification	Clamping range (mm)	Part number	Drawing (dimensions in mm)
<p>Circular connectors M23, Power, Cover, for bulkhead mounted housings, for cable to cable housing, With chain (70 mm)</p> 		09 15 600 9102	

M23



Contents

Page

Panel feed through .....

**D03 35.2**

7/8



Number of contacts

# 4

Unshielded

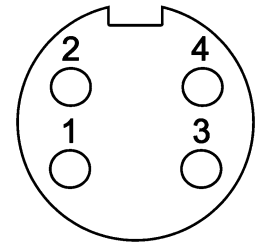

7/8

## Technical characteristics

Number of contacts	4
Rated current	10 A
Rated voltage conductor-earth	230 V
Rated voltage conductor-conductor	400 V
Rated impulse voltage	4.8 kV
Pollution degree	3
Insulation resistance	$>10^8 \Omega$
Contact resistance	$\leq 10 \text{ m}\Omega$
Mating cycles	$\geq 100$
Locking type	Screw locking
Conductor length	50 cm
Degree of protection acc. to IEC 60529	IP67

## Technical characteristics

Conductor cross-section	1 mm <sup>2</sup>
Conductor cross-section	AWG 18
Material (insert)	Thermoplastic polyurethane (TPU)
Material (hood/housing)	Copper-zinc alloy
Material (contacts)	Brass
Surface (contacts)	Gold plated
RoHS	compliant with exemption

## Specifications and approvals

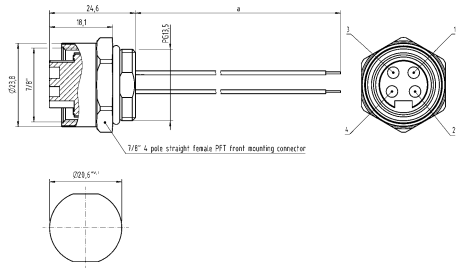

Identification	Conductor cross-section (mm <sup>2</sup> )	Part number Female	Drawing (dimensions in mm)
<p>Circular connectors 7/8", Panel feed through, With conductors, for front mounting, Unshielded</p> 	1	21 04 316 2401	 <p>7/8" 4 pole straight female PPT front assembling connector</p> <p>Panel cut out</p>

Number of contacts

**4+**

Unshielded

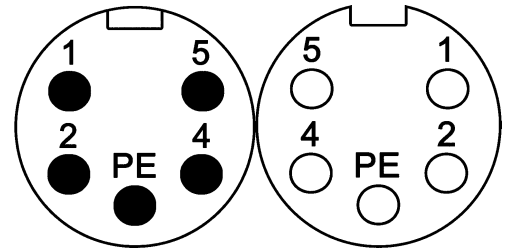

## Technical characteristics

Number of contacts	4
Rated current	10 A
Rated voltage conductor-earth	230 V
Rated voltage conductor-conductor	400 V
Rated impulse voltage	4.8 kV
Pollution degree	3
Insulation resistance	>10 <sup>8</sup> Ω
Contact resistance	≤10 mΩ
Mating cycles	≥100
Locking type	Screw locking
Conductor length	50 cm
Degree of protection acc. to IEC 60529	IP67

## Technical characteristics

Conductor cross-section	1 mm <sup>2</sup>
Conductor cross-section	AWG 18
Material (insert)	Thermoplastic polyurethane (TPU)
Material (hood/housing)	Copper-zinc alloy
Material (contacts)	Brass
Surface (contacts)	Gold plated
RoHS	compliant with exemption

## Specifications and approvals

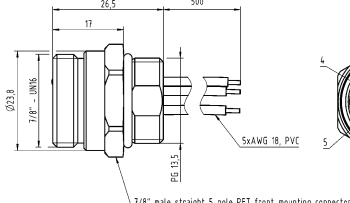
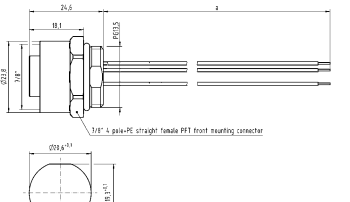

Identification	Conductor cross section (mm <sup>2</sup> )	Part number		Drawing (dimensions in mm)
		Male	Female	
Circular connectors 7/8", Panel feed through, With conductors, for front mounting, Unshielded 	1	21 34 740 0571 005	21 04 316 2501	 <p>3/8" male straight 5-pole PFT front-mounting connector</p>  <p>3/8" female straight 5-pole PFT front-mounting connector</p> <p>Panel cut out</p> <p>Panel cut out</p>

## Contents

## Page

Panel feed through .....

**D03 50.2**

HARAX

Accessories .....

**D03 50.6**

Number of contacts

**2+**

HARAX® connection technology  
Unshielded



## Technical characteristics

Number of contacts	2
Rated current	16 A
Rated voltage conductor-earth	230 V
Rated voltage conductor-conductor	400 V
Rated impulse voltage	4 kV
Pollution degree	3
Insulation resistance	>10 <sup>8</sup> Ω
Contact resistance	≤10 mΩ
Wire outer diameter	≤2.8 mm
Conductor length	50 cm
Degree of protection acc. to IEC 60529	IP67
Conductor cross-section	0.75 ... 1.5 mm <sup>2</sup>
Conductor cross-section	AWG 18 ... AWG 16

## Technical characteristics

Cable diameter	6 ... 9 mm
Material (insert)	Polyamide (PA), Thermoplastic polyurethane (TPU)
Material (hood/housing)	Polyamide (PA), Thermoplastic polyurethane (TPU)
Material (contacts)	Copper alloy
Surface (contacts)	Gold plated
RoHS	compliant

## Specifications and approvals

UL 1977 ECBT2.E102079  
CSA-C22.2 No. 182.3 ECBT8.E102079

Identification	Conductor cross-section (mm <sup>2</sup> )	Size	Part number	Drawing (dimensions in mm)
<p>HARAX®, Panel feed through, With faston blades, for front mounting, HARAX® connection technology, Unshielded</p>	0.75 ... 1.5	Pg 13.5	21 01 130 3013	<p>Contact arrangement (view from mating side)</p>
<p>HARAX®, Panel feed through, With solder termination, for front mounting, HARAX® connection technology, Unshielded</p>	0.75 ... 1.5	Pg 13.5	21 01 130 3023	
<p>HARAX®, Panel feed through, With conductors, for front mounting, HARAX® connection technology, Unshielded</p>	0.75 ... 1.5	Pg 13.5	21 01 130 3233	

Number of contacts

# 3

HARAX® connection technology  
Unshielded



HARAX

## Technical characteristics



Number of contacts	3
Rated current	16 A
Rated voltage conductor-earth	230 V
Rated voltage conductor-conductor	400 V
Rated impulse voltage	4 kV
Pollution degree	3
Insulation resistance	>10 <sup>8</sup> Ω
Contact resistance	≤10 mΩ
Wire outer diameter	≤2.8 mm
Conductor length	50 cm
Degree of protection acc. to IEC 60529	IP67
Conductor cross-section	0.75 ... 1.5 mm <sup>2</sup>
Conductor cross-section	AWG 18 ... AWG 16

## Technical characteristics

Cable diameter	6 ... 9 mm
Material (insert)	Polyamide (PA), Thermoplastic polyurethane (TPU)
Material (hood/housing)	Polyamide (PA), Thermoplastic polyurethane (TPU)
Material (contacts)	Copper alloy
Surface (contacts)	Gold plated
RoHS	compliant

## Specifications and approvals

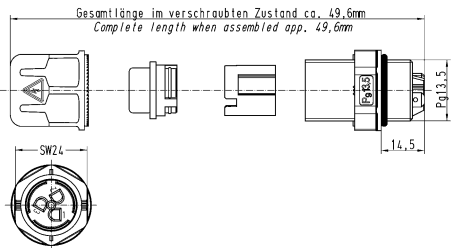
UL 1977 ECBT2.E102079  
CSA-C22.2 No. 182.3 ECBT8.E102079

Identification	Conductor cross-section (mm <sup>2</sup> )	Size	Part number	Drawing (dimensions in mm)
<p>HARAX®, Panel feed through, With faston blades, for front mounting, HARAX® connection technology, Unshielded</p> 	0.75 ... 1.5	Pg 13.5	21 01 130 1013	 <p>Contact arrangement (view from mating side)</p>
<p>HARAX®, Panel feed through, With solder termination, for front mounting, HARAX® connection technology, Unshielded</p> 	0.75 ... 1.5	Pg 13.5	21 01 130 1023	
<p>HARAX®, Panel feed through, With conductors, for front mounting, HARAX® connection technology, Unshielded</p> 	0.75 ... 1.5	Pg 13.5	21 01 130 1223	

Number of contacts

**3+**

HARAX® connection technology  
Unshielded



## Technical characteristics



Number of contacts	3
Rated current	16 A
Rated voltage conductor-earth	230 V
Rated voltage conductor-conductor	400 V
Rated impulse voltage	4 kV
Pollution degree	3
Insulation resistance	>10 <sup>8</sup> Ω
Contact resistance	≤10 mΩ
Wire outer diameter	≤2.8 mm
Conductor length	50 cm
Degree of protection acc. to IEC 60529	IP67
Conductor cross-section	0.75 ... 1.5 mm <sup>2</sup>
Conductor cross-section	AWG 18 ... AWG 16

## Technical characteristics

Cable diameter	6 ... 9 mm
Material (insert)	Polyamide (PA), Thermoplastic polyurethane (TPU)
Material (hood/housing)	Polyamide (PA), Thermoplastic polyurethane (TPU)
Material (contacts)	Copper alloy
Surface (contacts)	Gold plated
RoHS	compliant

## Specifications and approvals

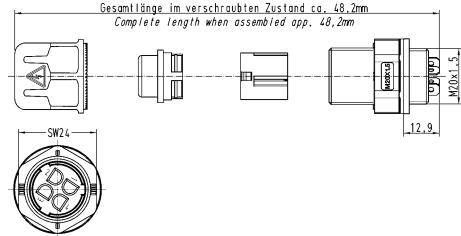
UL 1977 ECBT2.E102079  
CSA-C22.2 No. 182.3 ECBT8.E102079

Identification	Conductor cross-section (mm <sup>2</sup> )	Size	Part number	Drawing (dimensions in mm)
<p>HARAX®, Panel feed through, With solder termination, for front mounting, HARAX® connection technology, Unshielded</p> 	<p>0.75 ... 1.5 0.75 ... 1.5</p>	<p>M20 Pg 13.5</p>	<p>21 01 141 3023 21 01 140 3023</p>	 <p>Contact arrangement (view from mating side)</p>
<p>HARAX®, Panel feed through, With conductors, for front mounting, HARAX® connection technology, Unshielded</p> 	<p>0.75 ... 1.5</p>	<p>M20</p>	<p>21 01 141 3333</p>	

Number of contacts

# 4

HARAX® connection technology  
Unshielded



HARAX

## Technical characteristics



Number of contacts	4
Rated current	16 A
Rated voltage conductor-earth	230 V
Rated voltage conductor-conductor	400 V
Rated impulse voltage	4 kV
Pollution degree	3
Insulation resistance	>10 <sup>8</sup> Ω
Contact resistance	≤10 mΩ
Wire outer diameter	≤2.8 mm
Conductor length	50 cm
Degree of protection acc. to IEC 60529	IP67
Conductor cross-section	0.75 ... 1.5 mm <sup>2</sup>
Conductor cross-section	AWG 18 ... AWG 16

## Technical characteristics

Cable diameter	6 ... 9 mm
Material (insert)	Polyamide (PA), Thermoplastic polyurethane (TPU)
Material (hood/housing)	Polyamide (PA), Thermoplastic polyurethane (TPU)
Material (contacts)	Copper alloy
Surface (contacts)	Gold plated
RoHS	compliant

## Specifications and approvals

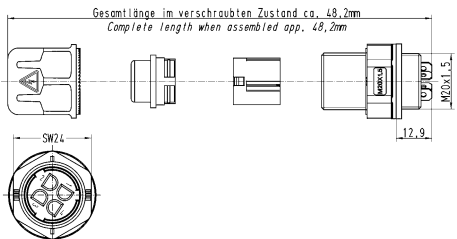

UL 1977 ECBT2.E102079  
CSA-C22.2 No. 182.3 ECBT8.E102079

Identification	Conductor cross-section (mm <sup>2</sup> )	Size	Part number	Drawing (dimensions in mm)
<p>HARAX®, Panel feed through, With solder termination, for front mounting, HARAX® connection technology, Unshielded</p> 	0.75 ... 1.5 0.75 ... 1.5	M20 Pg 13.5	21 01 141 1023 21 01 140 1023	 <p>Contact arrangement (view from mating side)</p>
<p>HARAX®, Panel feed through, With conductors, for front mounting, HARAX® connection technology, Unshielded</p> 	0.75 ... 1.5 0.75 ... 1.5	M20 Pg 13.5	21 01 141 1323 21 01 140 1323	

HARAX

## Technical characteristics

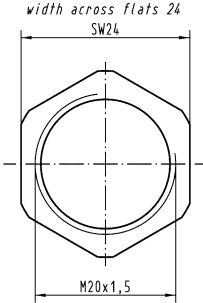
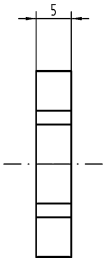
RoHS compliant with exemption, compliant

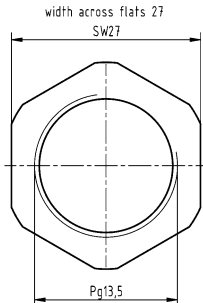
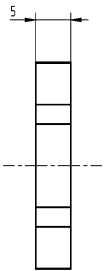
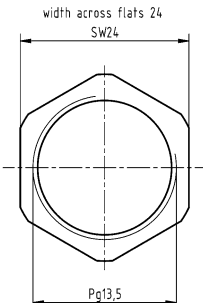
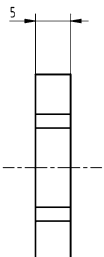
Identification	Size	Part number	Drawing (dimensions in mm)	
<p>HARAX®, Lock nut, Thermoplastic</p> 	M20 Pg 13.5	21 01 000 0009 21 01 000 0007	<p>width across flats 24 SW24</p>  <p>M20x1,5</p>	 <p>5</p>
<p>HARAX®, Lock nut, Metal</p> 	Pg 13.5	21 01 000 0039	<p>width across flats 27 SW27</p>  <p>Pg13,5</p>	 <p>5</p>
			<p>width across flats 24 SW24</p>  <p>Pg13,5</p>	 <p>5</p>

Contents

Page

M8.....

**C03 08.2**

M8

Accessories .....

**C03 08.11**

Number of contacts

3

HARAX® connection technology  
Unshielded

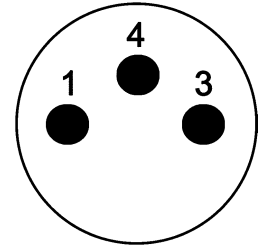

## Technical characteristics

Number of contacts	3
Rated current	2 A
Rated voltage	32 V
Rated impulse voltage	1.5 kV
Pollution degree	3
Insulation resistance	>10 <sup>8</sup> Ω
Contact resistance	≤10 mΩ
Mating cycles	≥100
Wire outer diameter	≤1 mm
Locking type	Screw locking
Degree of protection acc. to IEC 60529	IP67, in locked position
Conductor cross-section	0.1 ... 0.14 mm <sup>2</sup>

## Technical characteristics

Conductor cross-section	AWG 27 ... AWG 26
Cable diameter	1.9 ... 3.5 mm
Tightening torque	0.4 Nm
Material (insert)	Polyamide (PA)
Material (hood/housing)	Polyamide (PA), Zinc die-cast
Material (contacts)	Copper alloy
Surface (contacts)	Gold plated
RoHS	compliant with exemption

## Specifications and approvals

IEC 61076-2-104

Identification	Conductor cross-section (mm <sup>2</sup> )	Part number Male	Drawing (dimensions in mm)
----------------	--	---------------------	-------------------------------

Circular connectors M8,  
M8-XS,  
Cable connector,  
Straight,  
HARAX® connection technology,  
Unshielded



0.1 ... 0.14

21 02 159 1305

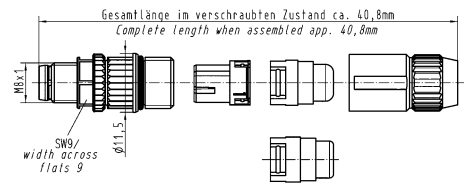

Number of contacts

**3**

HARAX® connection technology  
Unshielded

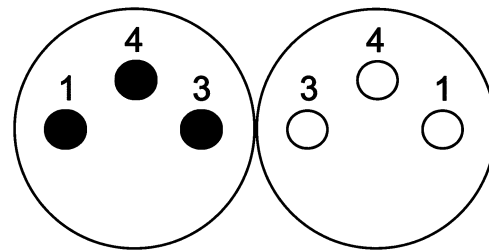

M8

### Technical characteristics

Number of contacts	3
Rated current	4 A
Rated voltage	32 V
Rated impulse voltage	1.5 kV
Pollution degree	3
Insulation resistance	>10 <sup>8</sup> Ω
Contact resistance	≤10 mΩ
Mating cycles	≥100
Wire outer diameter	≤1.6 mm
Locking type	Screw locking
Degree of protection acc. to IEC 60529	IP67, in locked position
Conductor cross-section	0.14 ... 0.34 mm <sup>2</sup>
Conductor cross-section	AWG 26 ... AWG 22

### Technical characteristics

Cable diameter	2.5 ... 5.1 mm
Tightening torque	0.4 Nm
Material (insert)	Polyamide (PA)
Material (hood/housing)	Polyamide (PA), Zinc die-cast
Material (contacts)	Copper alloy
Surface (contacts)	Gold plated
RoHS	compliant

### Specifications and approvals

IEC 61076-2-104  
UL 1977 ECBT2.E102079  
CSA-C22.2 No. 182.3 ECBT8.E102079

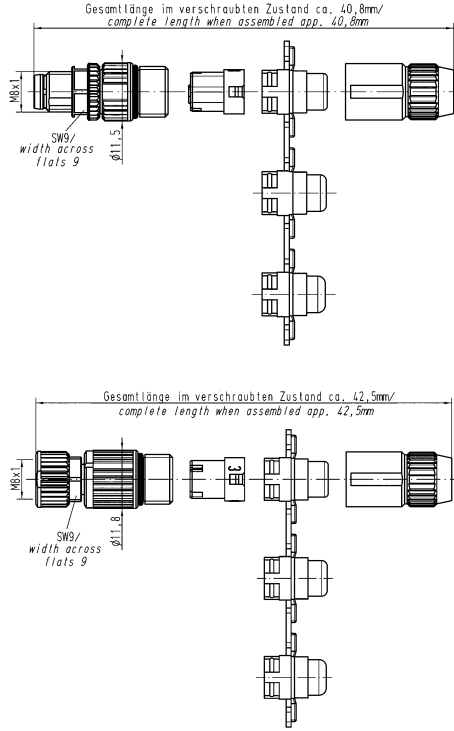
Identification	Conductor cross-section (mm <sup>2</sup> )	Part number		Drawing (dimensions in mm)
		Male	Female	
Circular connectors M8, M8-S, Cable connector, Straight, HARAX® connection technology, Unshielded 	0.14 ... 0.34	21 02 151 1305	21 02 151 2305	

Number of contacts

3

Screw termination  
Unshielded

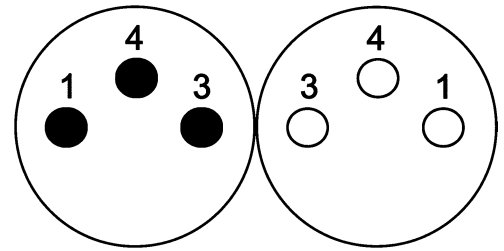

### Technical characteristics

Number of contacts	3
Rated current	4 A
Rated voltage	60 V
Rated impulse voltage	1.5 kV
Pollution degree	3
Insulation resistance	>10 <sup>8</sup> Ω
Contact resistance	≤10 mΩ
Mating cycles	≥100
Locking type	Screw locking
Degree of protection acc. to IEC 60529	IP67, in locked position
Conductor cross-section	0.09 ... 0.5 mm <sup>2</sup>
Conductor cross-section	AWG 28 ... AWG 20

### Technical characteristics

Cable diameter	4 ... 5.5 mm
Tightening torque	0.4 Nm
Material (insert)	Polyamide (PA)
Material (hood/housing)	Polyamide (PA), Copper-zinc alloy
Material (contacts)	Brass
Surface (contacts)	Gold plated
RoHS	compliant with exemption

### Specifications and approvals

IEC 61076-2-104

Identification	Conductor cross-section (mm <sup>2</sup> )	Part number		Drawing (dimensions in mm)
		Male	Female	
Circular connectors M8, Cable connector, Straight, Screw termination, Unshielded  	0.09 ... 0.5	21 02 359 1301	21 02 359 2301	
Circular connectors M8, Cable connector, Angled, Screw termination, Unshielded  	0.09 ... 0.5	21 02 359 3301	21 02 359 4301	

Number of contacts

**3**

Screw termination  
Shielded

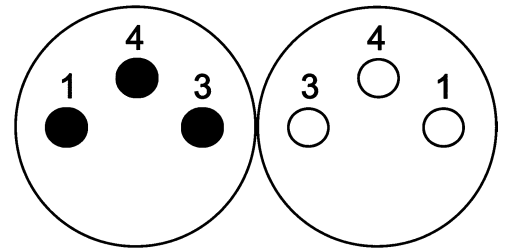

M8

### Technical characteristics

Number of contacts	3
Rated current	4 A
Rated voltage	60 V
Rated impulse voltage	1.5 kV
Pollution degree	3
Insulation resistance	>10 <sup>8</sup> Ω
Contact resistance	≤10 mΩ
Mating cycles	≥100
Locking type	Screw locking
Degree of protection acc. to IEC 60529	IP67, in locked position
Conductor cross-section	0.09 ... 0.5 mm <sup>2</sup>
Conductor cross-section	AWG 28 ... AWG 20

### Technical characteristics

Cable diameter	4 ... 5.5 mm
Tightening torque	0.4 Nm
Material (insert)	Polyamide (PA)
Material (hood/housing)	Copper-zinc alloy
Material (contacts)	Brass
Surface (contacts)	Gold plated
RoHS	compliant with exemption

### Specifications and approvals

IEC 61076-2-104

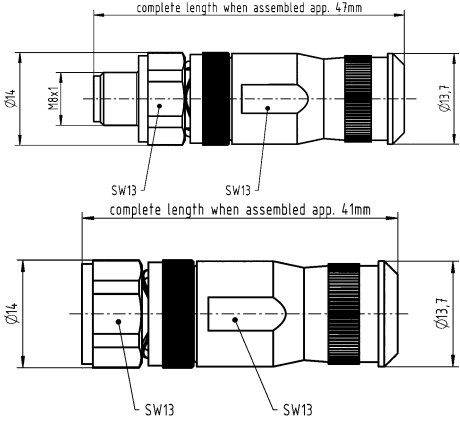
Identification	Conductor cross-section (mm <sup>2</sup> )	Part number		Drawing (dimensions in mm)
		Male	Female	
Circular connectors M8, Cable connector, Straight, Screw termination, Shielded 	0.09 ... 0.5	21 02 369 1301	21 02 369 2301	

Number of contacts

**4**

HARAX® connection technology  
Unshielded

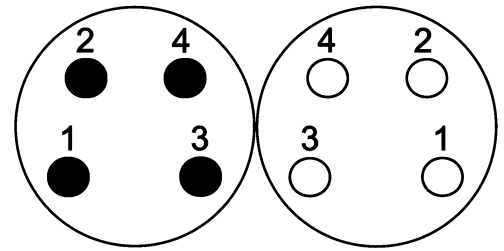

### Technical characteristics

Number of contacts	4
Rated current	4 A
Rated voltage	32 V
Rated impulse voltage	1.5 kV
Pollution degree	3
Insulation resistance	>10 <sup>8</sup> Ω
Contact resistance	≤10 mΩ
Mating cycles	≥100
Wire outer diameter	≤1.6 mm
Locking type	Screw locking
Degree of protection acc. to IEC 60529	IP67, in locked position
Conductor cross-section	0.14 ... 0.34 mm <sup>2</sup>
Conductor cross-section	AWG 26 ... AWG 22

### Technical characteristics

Cable diameter	2.5 ... 5.1 mm
Tightening torque	0.4 Nm
Material (insert)	Polyamide (PA)
Material (hood/housing)	Polyamide (PA), Zinc die-cast
Material (contacts)	Copper alloy
Surface (contacts)	Gold plated
RoHS	compliant

### Specifications and approvals

IEC 61076-2-104  
UL 1977 ECBT2.E102079  
CSA-C22.2 No. 182.3 ECBT8.E102079

Identification	Conductor cross-section (mm <sup>2</sup> )	Part number		Drawing (dimensions in mm)
		Male	Female	
Circular connectors M8, M8-S, Cable connector, Straight, HARAX® connection technology, Unshielded 	0.14 ... 0.34	21 02 151 1405	21 02 151 2405	

Number of contacts

4

Screw termination  
Unshielded

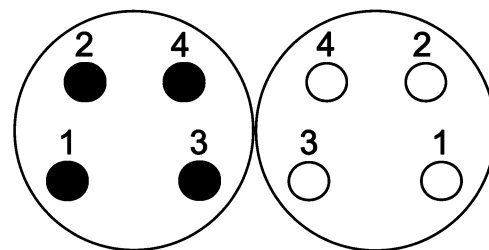

M8

### Technical characteristics



Number of contacts	4
Rated current	4 A
Rated voltage	30 V
Rated impulse voltage	1.5 kV
Pollution degree	3
Insulation resistance	>10 <sup>8</sup> Ω
Contact resistance	≤10 mΩ
Mating cycles	≥100
Locking type	Screw locking
Degree of protection acc. to IEC 60529	IP67, in locked position
Conductor cross-section	0.09 ... 0.5 mm <sup>2</sup>
Conductor cross-section	AWG 28 ... AWG 20

### Technical characteristics

Cable diameter	4 ... 5.5 mm
Tightening torque	0.4 Nm
Material (insert)	Polyamide (PA)
Material (hood/housing)	Polyamide (PA), Copper-zinc alloy
Material (contacts)	Brass
Surface (contacts)	Gold plated
RoHS	compliant with exemption

### Specifications and approvals

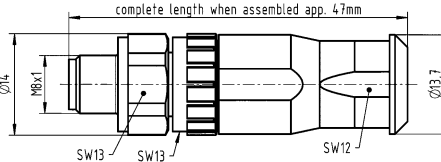
IEC 61076-2-104

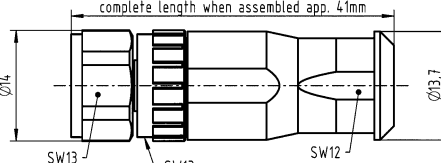
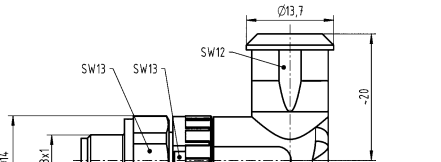
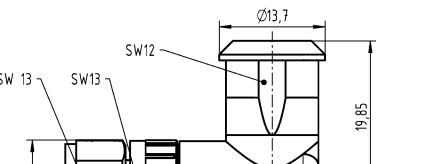
Identification	Conductor cross-section (mm <sup>2</sup> )	Part number		Drawing (dimensions in mm)
		Male	Female	
Circular connectors M8, Cable connector, Straight, Screw termination, Unshielded  	0.09 ... 0.5	21 02 359 1401	21 02 359 2401	
Circular connectors M8, Cable connector, Angled, Screw termination, Unshielded  	0.09 ... 0.5	21 02 359 3401	21 02 359 4401	  

Number of contacts

**4**

Screw termination  
Shielded

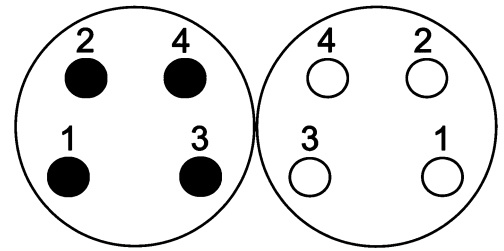

### Technical characteristics

Number of contacts	4
Rated current	4 A
Rated voltage	30 V
Rated impulse voltage	1.5 kV
Pollution degree	3
Insulation resistance	>10 <sup>8</sup> Ω
Contact resistance	≤10 mΩ
Mating cycles	≥100
Locking type	Screw locking
Degree of protection acc. to IEC 60529	IP67, in locked position
Conductor cross-section	0.09 ... 0.5 mm <sup>2</sup>
Conductor cross-section	AWG 28 ... AWG 20

### Technical characteristics

Cable diameter	4 ... 5.5 mm
Tightening torque	0.4 Nm
Material (insert)	Polyamide (PA)
Material (hood/housing)	Copper-zinc alloy
Material (contacts)	Brass
Surface (contacts)	Gold plated
RoHS	compliant with exemption

### Specifications and approvals

IEC 61076-2-104

Identification	Conductor cross-section (mm <sup>2</sup> )	Part number		Drawing (dimensions in mm)
		Male	Female	
Circular connectors M8, Cable connector, Straight, Screw termination, Shielded  	0.09 ... 0.5	21 02 369 1401	21 02 369 2401	

Number of contacts

4

HARAX® connection technology  
Shielded

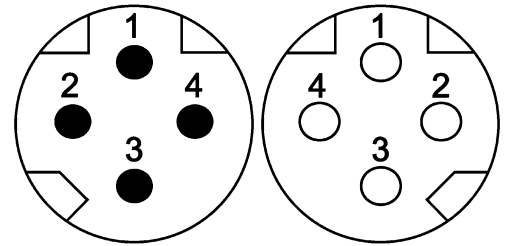

M8

### Technical characteristics

Number of contacts	4
Rated current	4 A
Rated voltage	60 V
Rated impulse voltage	1.5 kV
Pollution degree	3
Insulation resistance	>10 <sup>8</sup> Ω
Contact resistance	≤10 mΩ
Mating cycles	≥100
Locking type	Screw locking, PushPull
Degree of protection acc. to IEC 60529	IP65 / IP67, in locked position
Cable diameter	6.2 ... 6.8 mm

### Technical characteristics

Transmission characteristics	Cat. 5, Class D up to 100 MHz
Tightening torque	0.4 Nm
Material (insert)	Polyamide (PA)
Material (hood/housing)	Polyamide (PA), Zinc die-cast
Material (contacts)	Copper alloy
Surface (contacts)	Gold plated

### Specifications and approvals

IEC 61076-2-114

Identification	Part number		Drawing (dimensions in mm)
	Male	Female	
Circular connectors M8, Cable connector, Straight, HARAX® connection technology, Shielded, Screw locking	21 02 185 1405	21 02 185 2405	
Circular connectors M8, Cable connector, Straight, HARAX® connection technology, Shielded, PushPull locking	21 02 185 1430		

Number of contacts

4

HARAX® connection technology  
Shielded

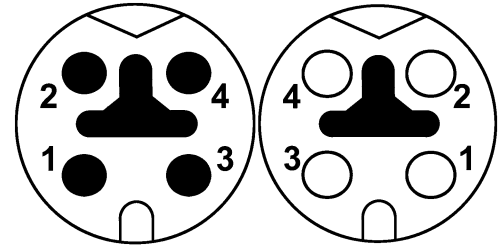

### Technical characteristics

Number of contacts	4
Rated current	4 A
Rated voltage	60 V
Rated impulse voltage	1.5 kV
Pollution degree	3
Insulation resistance	>10 <sup>8</sup> Ω
Contact resistance	≤10 mΩ
Mating cycles	≥100
Locking type	Screw locking, PushPull
Degree of protection acc. to IEC 60529	IP65 / IP67, in locked position
Cable diameter	6.2 ... 6.8 mm

### Technical characteristics

Transmission characteristics	Cat. 5, Class D up to 100 MHz
Tightening torque	0.4 Nm
Material (insert)	Polyamide (PA)
Material (hood/housing)	Polyamide (PA), Zinc die-cast
Material (contacts)	Copper alloy
Surface (contacts)	Gold plated

### Specifications and approvals

IEC 61076-2-114



Identification	Part number		Drawing (dimensions in mm)
	Male	Female	
Circular connectors M8, Cable connector, Straight, HARAX® connection technology, Shielded, Screw locking	21 02 145 1405	21 02 145 2405	
Circular connectors M8, Cable connector, Straight, HARAX® connection technology, Shielded, PushPull locking	21 02 145 1430		

## Technical characteristics

Material (accessories) Thermoplastic

## Technical characteristics

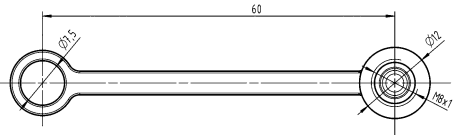
Colour (accessories) Black  
RoHS compliant

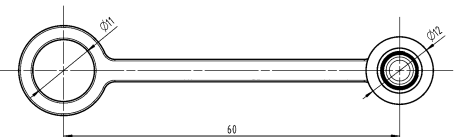
Identification	Part number	Drawing (dimensions in mm)
<p>Circular connectors M8, Cap, for male inserts, with cord</p> 	<p>21 41 000 0003</p>	
<p>Circular connectors M8, Cap, for female inserts, with cord</p> 	<p>21 41 000 0004</p>	





M8

## Technical characteristics

Material (accessories) Thermoplastic

## Technical characteristics

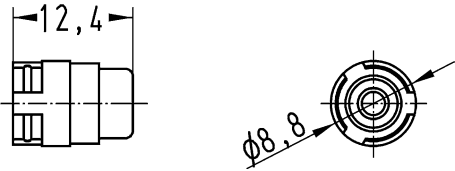
Colour (accessories) Black, Grey, Transparent  
RoHS compliant

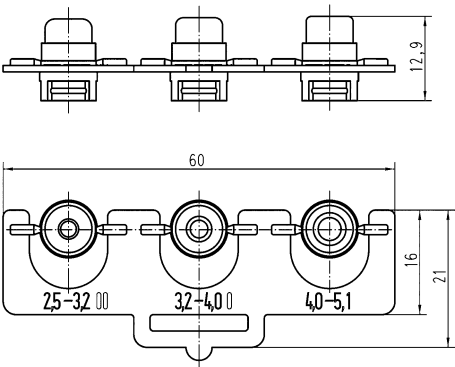
Identification	Cable diameter (mm)	Part number	Drawing (dimensions in mm)
Circular connectors M8, M8-XS, Seal, Black 	1.9 ... 2.5	21 01 010 2016	
Circular connectors M8, M8-XS, Seal, Grey 	2.5 ... 3.5	21 01 010 2008	
Circular connectors M8, M8-XS, Seal, Transparent 	4.2 ... 5.4	21 01 010 2005	
Circular connectors M8, M8-S, Set of seals 	2.5 ... 5.1	21 01 010 2013	

C03  
08  
·  
12

Contents	Page
M12.....	<b>C03 12.2</b>
preLink® M12.....	<b>C03 12.32</b>
M12 Slim Design .....	<b>C03 12.40</b>
M12 PushPull .....	<b>C03 12.60</b>
M12 Power .....	<b>C03 12.74</b>
Adapter .....	<b>C03 12.82</b>
Accessories .....	<b>C03 12.87</b>

Number of contacts

**3**

HARAX® connection technology  
Unshielded

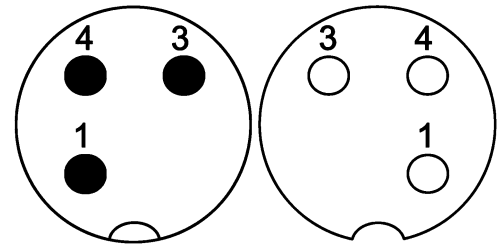

**Technical characteristics**

Number of contacts	3
Rated current	4 A
Rated voltage	32 V
Rated impulse voltage	1.5 kV
Pollution degree	3
Insulation resistance	>10 <sup>8</sup> Ω
Contact resistance	≤10 mΩ
Mating cycles	≥100
Wire outer diameter	≤1.6 mm
Locking type	Screw locking
Degree of protection acc. to IEC 60529	IP65 / IP67, when mated
Conductor cross-section	0.14 ... 0.34 mm <sup>2</sup>
Conductor cross-section	AWG 26 ... AWG 22

**Technical characteristics**

Cable diameter	2.9 ... 5.1 mm
Tightening torque	0.6 Nm
Material (insert)	Polyamide (PA)
Material (hood/housing)	Polyamide (PA), Zinc die-cast
Material (contacts)	Brass
Surface (contacts)	Gold plated
RoHS	compliant

**Specifications and approvals**

IEC 61076-2-101  
UL 1977 ECBT2.E102079  
CSA-C22.2 No. 182.3 ECBT8.E102079

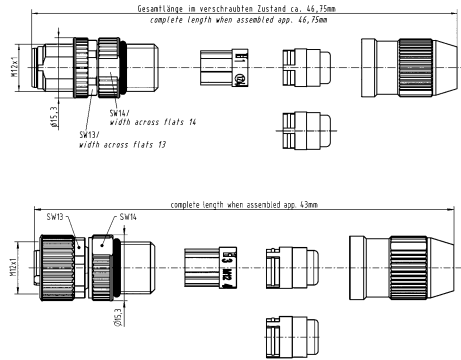
Identification	Conductor cross-section (mm <sup>2</sup> )	Part number		Drawing (dimensions in mm)
		Male	Female	
Circular connectors M12, M12-S, Cable connector, Straight, HARAX® connection technology, Unshielded 	0.14 ... 0.34	21 03 111 1305	21 03 111 2305	

Number of contacts

**3**

HARAX® connection technology  
Unshielded

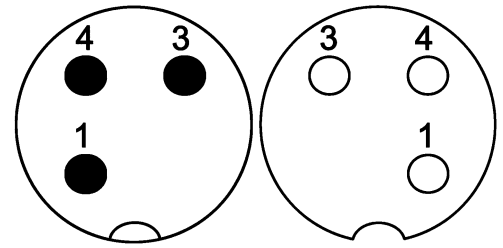

M12

### Technical characteristics

Number of contacts	3
Rated current	6 A
Rated voltage	50 V
Rated impulse voltage	1.5 kV
Pollution degree	3
Insulation resistance	>10 <sup>8</sup> Ω
Contact resistance	≤10 mΩ
Mating cycles	≥100
Wire outer diameter	≤2.6 mm
Locking type	Screw locking
Degree of protection acc. to IEC 60529	IP65 / IP67, when mated
Conductor cross-section	0.34 ... 0.75 mm <sup>2</sup>
Conductor cross-section	AWG 22 ... AWG 18

### Technical characteristics

Cable diameter	6 ... 8 mm
Tightening torque	0.6 Nm
Material (insert)	Polyamide (PA)
Material (hood/housing)	Polyamide (PA), Zinc die-cast
Material (contacts)	Brass
Surface (contacts)	Gold plated
RoHS	compliant with exemption

### Specifications and approvals

IEC 61076-2-101  
UL 1977 ECBT2.E102079  
CSA-C22.2 No. 182.3 ECBT8.E102079

Identification	Conductor cross-section (mm <sup>2</sup> )	Part number		Drawing (dimensions in mm)
		Male	Female	
Circular connectors M12, M12-L, Cable connector, Straight, Deviating contact configuration, 1, 3, 4, HARAX® connection technology, Unshielded 	0.34 ... 0.75	21 03 212 1306	21 03 212 2306	
Circular connectors M12, M12-L, Cable connector, Straight, Deviating contact configuration, 3, 4, 5, HARAX® connection technology, Unshielded 	0.34 ... 0.75	21 03 212 1400	21 03 212 2400	

Number of contacts

**4**

HARAX® connection technology  
Unshielded

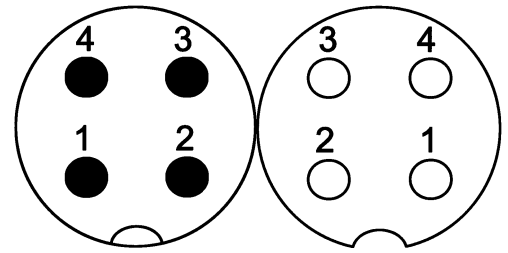

### Technical characteristics

Number of contacts	4
Rated current	4 A
Rated voltage	32 V
Rated impulse voltage	1.5 kV
Pollution degree	3
Insulation resistance	>10 <sup>8</sup> Ω
Contact resistance	≤10 mΩ
Mating cycles	≥100
Wire outer diameter	≤1.6 mm
Locking type	Screw locking
Degree of protection acc. to IEC 60529	IP65 / IP67, when mated
Conductor cross-section	0.14 ... 0.34 mm <sup>2</sup>
Conductor cross-section	AWG 26 ... AWG 22

### Technical characteristics

Cable diameter	2.9 ... 5.1 mm
Tightening torque	0.6 Nm
Material (insert)	Polyamide (PA)
Material (hood/housing)	Polyamide (PA), Zinc die-cast
Material (contacts)	Brass
Surface (contacts)	Gold plated
RoHS	compliant

### Specifications and approvals

IEC 61076-2-101  
UL 1977 ECBT2.E102079  
CSA-C22.2 No. 182.3 ECBT8.E102079

Identification	Conductor cross-section (mm <sup>2</sup> )	Part number		Drawing (dimensions in mm)
		Male	Female	
Circular connectors M12, M12-S, Cable connector, Straight, HARAX® connection technology, Unshielded,  	0.14 ... 0.34	21 03 111 1405	21 03 111 2405	

Number of contacts

4

HARAX® connection technology  
Unshielded

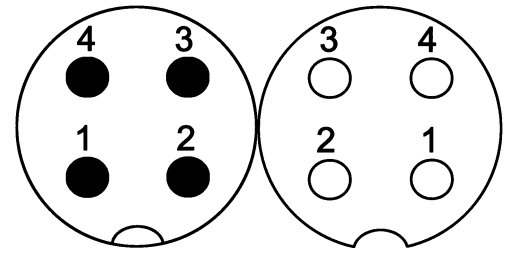

M12

### Technical characteristics



Number of contacts	4
Rated current	6 A
Rated voltage	50 V
Rated impulse voltage	1.5 kV
Pollution degree	3
Insulation resistance	>10 <sup>8</sup> Ω
Contact resistance	≤10 mΩ
Mating cycles	≥100
Wire outer diameter	≤2.6 mm
Locking type	Screw locking
Degree of protection acc. to IEC 60529	IP65 / IP67, when mated
Conductor cross-section	0.34 ... 0.75 mm <sup>2</sup>
Conductor cross-section	AWG 22 ... AWG 18

### Technical characteristics

Cable diameter	6 ... 8 mm, 7 ... 8.8 mm
Tightening torque	0.6 Nm
Material (insert)	Polyamide (PA)
Material (hood/housing)	Polyamide (PA), Zinc die-cast
Material (contacts)	Brass
Surface (contacts)	Gold plated
RoHS	compliant with exemption

### Specifications and approvals

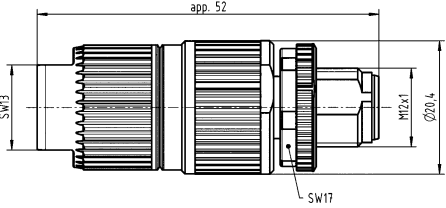
IEC 61076-2-101  
UL 1977 ECBT2.E102079  
CSA-C22.2 No. 182.3 ECBT8.E102079

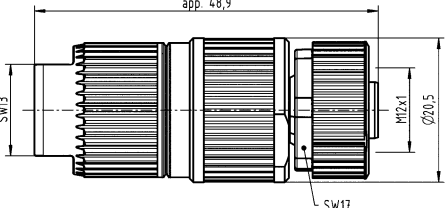
Identification	Conductor cross-section (mm <sup>2</sup> )	Part number		Drawing (dimensions in mm)
		Male	Female	
Circular connectors M12, M12-L, Cable connector, Straight, HARAX® connection technology, Unshielded 	0.34 ... 0.75	21 03 212 1305	21 03 212 2305	
Circular connectors M12, M12-L, Cable connector, Straight, HARAX® connection technology, Unshielded, Cable-Ø 7 ... 8.8 mm 	0.34 ... 0.75	21 03 212 1407	21 03 212 2407	

Number of contacts

**4**

HARAX® connection technology  
Unshielded

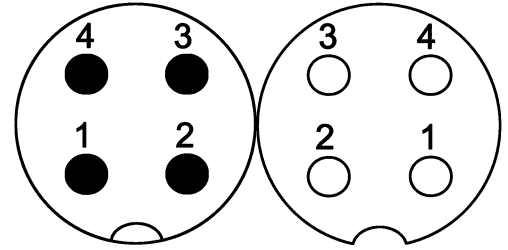

### Technical characteristics

Number of contacts	4
Rated current	4 A
Rated voltage	32 V
Rated impulse voltage	1.5 kV
Pollution degree	3
Insulation resistance	>10 <sup>8</sup> Ω
Contact resistance	≤10 mΩ
Mating cycles	≥100
Wire outer diameter	≤1.6 mm
Locking type	Screw locking
Degree of protection acc. to IEC 60529	IP65 / IP67, when mated
Conductor cross-section	0.25 ... 0.5 mm <sup>2</sup>
Conductor cross-section	AWG 24 ... AWG 20

### Technical characteristics

Cable diameter	4 ... 5.1 mm
Tightening torque	0.6 Nm
Material (insert)	Polyamide (PA)
Material (hood/housing)	Polyamide (PA), Zinc die-cast
Material (contacts)	Brass
Surface (contacts)	Gold plated
RoHS	compliant

### Specifications and approvals

IEC 61076-2-101  
UL 1977 ECBT2.E102079  
CSA-C22.2 No. 182.3 ECBT8.E102079

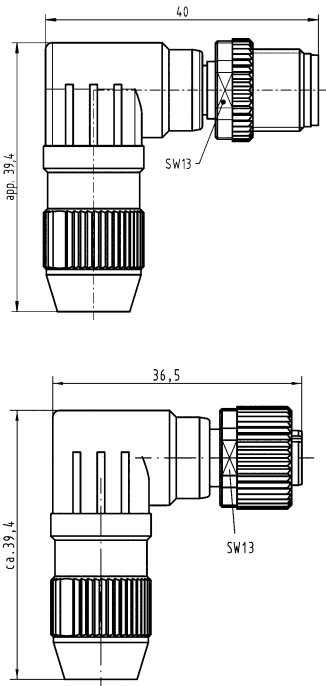
Identification	Conductor cross-section (mm <sup>2</sup> )	Part number		Drawing (dimensions in mm)
		Male	Female	
Circular connectors M12, Cable connector, Angled, HARAX® connection technology, Unshielded,  	0.25 ... 0.5	21 01 140 5081	21 01 140 5091	

Number of contacts

4

HARAX® connection technology  
Shielded

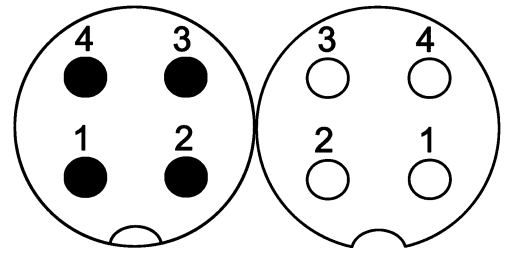

M12

### Technical characteristics

Number of contacts	4
Rated current	4 A
Rated voltage	50 V
Rated impulse voltage	1.5 kV
Pollution degree	3
Insulation resistance	>10 <sup>8</sup> Ω
Contact resistance	≤10 mΩ
Mating cycles	≥100
Wire outer diameter	≤1.6 mm
Locking type	Screw locking
Degree of protection acc. to IEC 60529	IP65 / IP67, when mated
Conductor cross-section	0.14 ... 0.34 mm <sup>2</sup>
Conductor cross-section	AWG 26 ... AWG 22

### Technical characteristics

Cable diameter	4.5 ... 8.8 mm
Tightening torque	0.6 Nm, 2 Nm Lock nut
Material (insert)	Polyamide (PA)
Material (hood/housing)	Zinc die-cast
Material (contacts)	Brass
Surface (contacts)	Gold plated
RoHS	compliant with exemption

### Specifications and approvals

IEC 61076-2-101  
UL 1977 ECBT2.E102079  
CSA-C22.2 No. 182.3 ECBT8.E102079

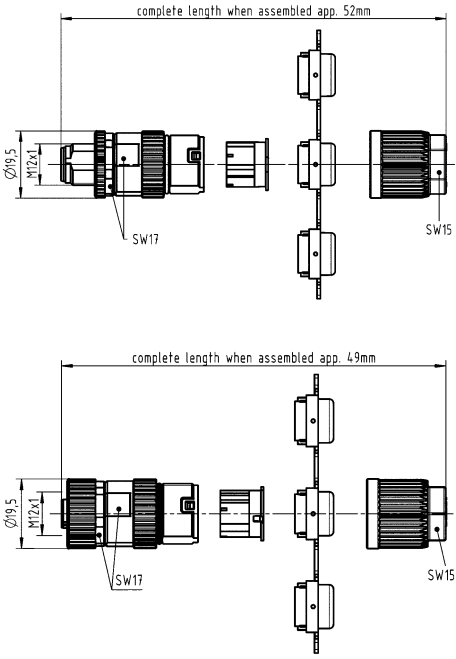
Identification	Conductor cross-section (mm <sup>2</sup> )	Part number		Drawing (dimensions in mm)
		Male	Female	
Circular connectors M12, M12-L, Cable connector, Straight, HARAX® connection technology, Shielded 	0.14 ... 0.34	21 03 221 1405	21 03 221 2405	

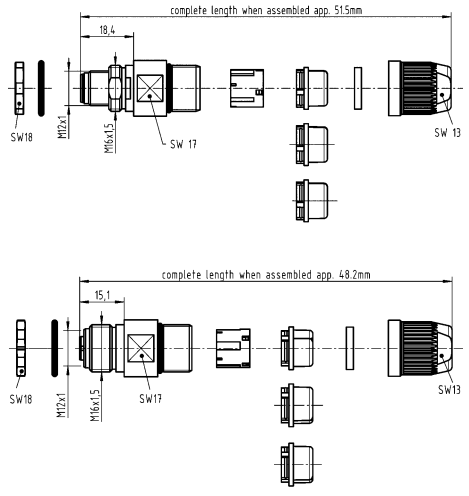
Identification	Conductor cross-section (mm <sup>2</sup> )	Part number		Drawing (dimensions in mm)
		Male	Female	
<p>Circular connectors M12, M12-L, Cable connector, Panel feed through, for rear mounting, HARAX® connection technology, Shielded</p> 	0.14 ... 0.34	21 03 321 1425	21 03 321 2425	

Number of contacts

**4**

Screw termination  
Unshielded

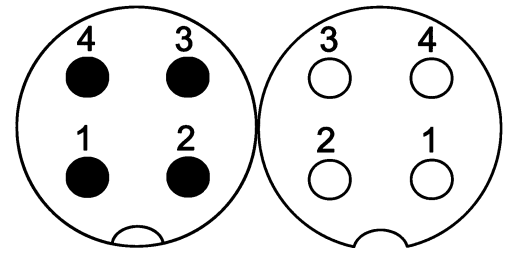

M12

### Technical characteristics

Number of contacts	4
Rated current	7.5 A
Rated voltage	250 V
Rated impulse voltage	1.5 kV
Pollution degree	3
Insulation resistance	>10 <sup>8</sup> Ω
Contact resistance	≤10 mΩ
Mating cycles	≥100
Locking type	Screw locking
Degree of protection acc. to IEC 60529	IP67, when mated
Conductor cross-section	1.5 mm <sup>2</sup> max.
Conductor cross-section	AWG 16

### Technical characteristics

Cable diameter	4 ... 8 mm
Tightening torque	0.6 Nm
Material (insert)	Polyamide (PA)
Material (hood/housing)	Polyamide (PA), Zinc die-cast
Material (contacts)	Brass
Surface (contacts)	Gold plated
RoHS	compliant with exemption

### Specifications and approvals

IEC 61076-2-101

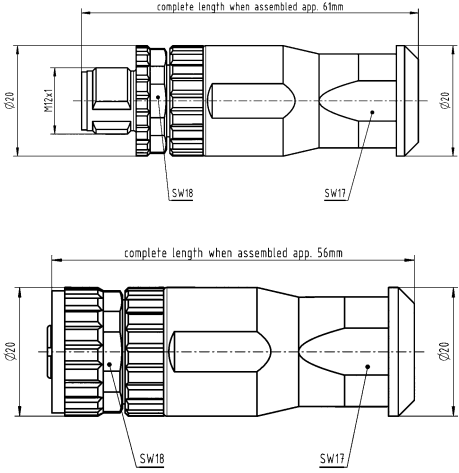
Identification	Conductor cross-section (mm <sup>2</sup> )	Part number		Drawing (dimensions in mm)
		Male	Female	
Circular connectors M12, Cable connector, Straight, Screw termination, Unshielded 	1.5 max.	21 03 319 1401	21 03 319 2401	

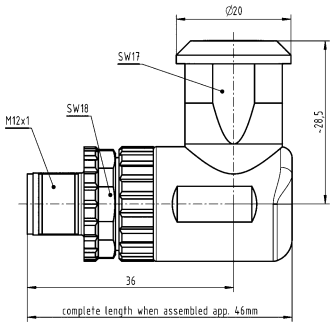
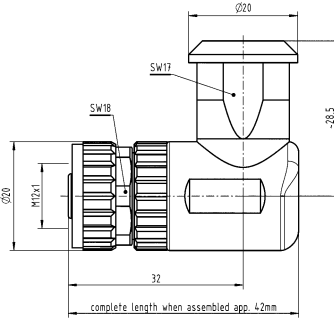
Identification	Conductor cross-section (mm <sup>2</sup> )	Part number		Drawing (dimensions in mm)
		Male	Female	
<p>Circular connectors M12, Cable connector, Angled, Screw termination, Unshielded</p> 	1.5 max.	21 03 319 3401	21 03 319 4401	 

Number of contacts

**4**

Screw termination  
Shielded

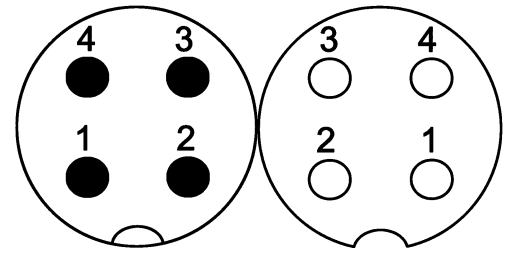

M12

### Technical characteristics

Number of contacts	4
Rated current	4 A
Rated voltage	250 V
Rated impulse voltage	1.5 kV
Pollution degree	3
Insulation resistance	>10 <sup>8</sup> Ω
Contact resistance	≤10 mΩ
Mating cycles	≥100
Locking type	Screw locking
Degree of protection acc. to IEC 60529	IP67, when mated
Conductor cross-section	1.5 mm <sup>2</sup> max.
Conductor cross-section	AWG 16

### Technical characteristics

Cable diameter	4 ... 8 mm
Tightening torque	0.6 Nm
Material (insert)	Polyamide (PA)
Material (hood/housing)	Zinc die-cast
Material (contacts)	Brass
Surface (contacts)	Gold plated
RoHS	compliant with exemption

### Specifications and approvals

IEC 61076-2-101

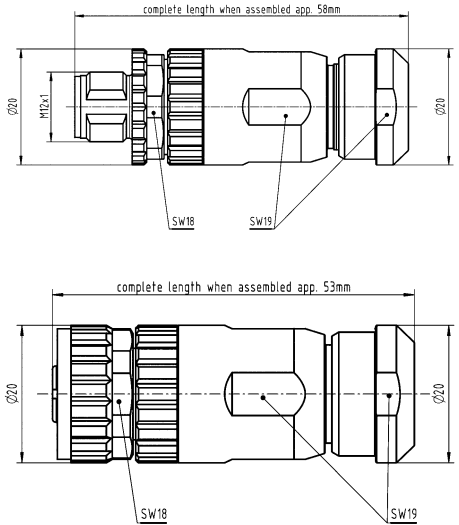
Identification	Conductor cross-section (mm <sup>2</sup> )	Part number		Drawing (dimensions in mm)
		Male	Female	
Circular connectors M12, Cable connector, Straight, Screw termination, Shielded 	1.5 max.	21 03 329 1401	21 03 329 2401	

Number of contacts

**5**

HARAX® connection technology  
Unshielded

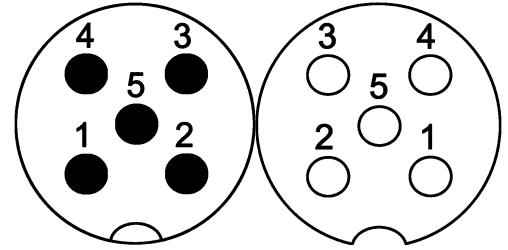

### Technical characteristics

Number of contacts	5
Rated current	4 A
Rated voltage	50 V
Rated impulse voltage	1.5 kV
Pollution degree	3
Insulation resistance	>10 <sup>8</sup> Ω
Contact resistance	≤10 mΩ
Mating cycles	≥100
Wire outer diameter	≤2 mm
Locking type	Screw locking
Degree of protection acc. to IEC 60529	IP65 / IP67, when mated
Conductor cross-section	0.34 ... 0.5 mm <sup>2</sup>
Conductor cross-section	AWG 22 ... AWG 20

### Technical characteristics

Cable diameter	6 ... 8 mm
Tightening torque	0.6 Nm
Material (insert)	Polyamide (PA)
Material (hood/housing)	Polyamide (PA), Zinc die-cast
Material (contacts)	Brass
Surface (contacts)	Gold plated
RoHS	compliant with exemption

### Specifications and approvals

IEC 61076-2-101  
UL 1977 ECBT2.E102079  
CSA-C22.2 No. 182.3 ECBT8.E102079

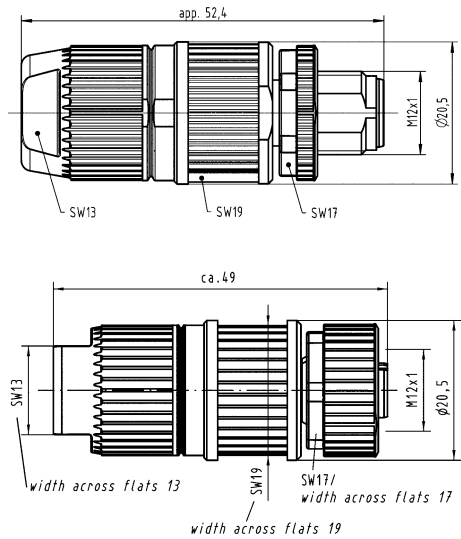
Identification	Conductor cross-section (mm <sup>2</sup> )	Part number		Drawing (dimensions in mm)
		Male	Female	
Circular connectors M12, M12-L, Cable connector, Straight, HARAX® connection technology, Unshielded 	0.34 ... 0.5	21 03 272 1505	21 03 272 2505	

Number of contacts

5

Crimp termination  
Shielded

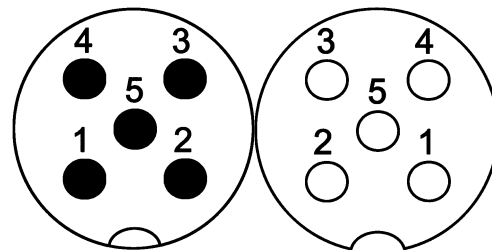

M12

### Technical characteristics



Number of contacts	5
Rated current	4 A
Rated impulse voltage	1.5 kV
Pollution degree	3
Rated voltage	48 V AC, 60 V DC
Insulation resistance	>10 <sup>8</sup> Ω
Contact resistance	≤10 mΩ
Mating cycles	≥500
Wire outer diameter	≤2.3 mm
Locking type	Screw locking
Degree of protection acc. to IEC 60529	IP65 / IP67, when mated
Conductor cross-section	0.14 ... 0.75 mm <sup>2</sup> , 0.09 ... 0.25 mm <sup>2</sup> , 0.13 ... 0.33 mm <sup>2</sup> , 0.25 ... 0.52 mm <sup>2</sup> , 0.33 ... 0.82 mm <sup>2</sup>

### Technical characteristics

Conductor cross-section	AWG 26 ... AWG 18, AWG 28 ... AWG 24, AWG 26 ... AWG 22, AWG 24 ... AWG 20, AWG 22 ... AWG 18
Cable diameter	4.5 ... 8.8 mm
Tightening torque	0.6 Nm
Material (insert)	Polyamide (PA)
Material (hood/housing)	Zinc die-cast
Material (contacts)	Copper alloy
RoHS	compliant, compliant with exemption

### Specifications and approvals

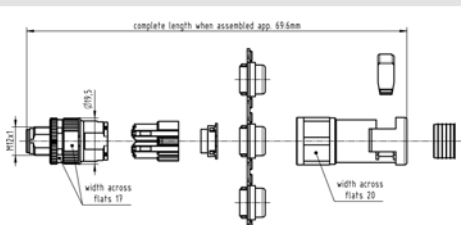
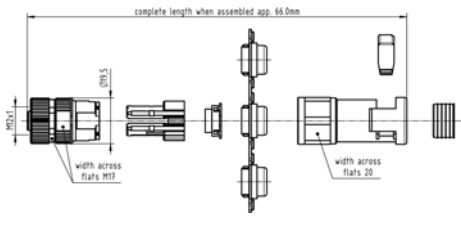
IEC 61076-2-101  
UL 1977 ECBT2.E102079  
CSA-C22.2 No. 182.3 ECBT8.E102079

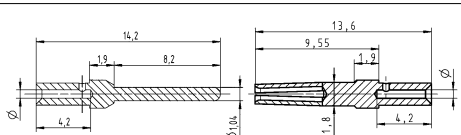
Identification	Conductor cross-section (mm <sup>2</sup> )	Part number		Drawing (dimensions in mm)															
		Male	Female																
Circular connectors M12, Cable connector, with conduit, Straight, Crimp termination, Shielded   Please order crimp contacts separately.	0.14 ... 0.75	21 03 812 1511	21 03 812 2511	 															
D-Sub, Standard, Crimp contact, Turned contacts  	0.09 ... 0.25 0.13 ... 0.33 0.25 ... 0.52 0.33 ... 0.82	09 67 000 7576 09 67 000 5576 09 67 000 8576 09 67 000 3576	09 67 000 7476 09 67 000 5476 09 67 000 8476 09 67 000 3476	 <table border="1"> <thead> <tr> <th>Wire gauge</th> <th>Ø</th> <th>Stripping length</th> </tr> </thead> <tbody> <tr> <td>0.09-0.25 mm<sup>2</sup></td> <td>0.64 mm</td> <td>4 mm</td> </tr> <tr> <td>0.13-0.33 mm<sup>2</sup></td> <td>0.88 mm</td> <td>4 mm</td> </tr> <tr> <td>0.25-0.52 mm<sup>2</sup></td> <td>1.13 mm</td> <td>4 mm</td> </tr> <tr> <td>0.33-0.82 mm<sup>2</sup></td> <td>1.34 mm</td> <td>4 mm</td> </tr> </tbody> </table> for stranded wire according IEC 60228 Class 5	Wire gauge	Ø	Stripping length	0.09-0.25 mm <sup>2</sup>	0.64 mm	4 mm	0.13-0.33 mm <sup>2</sup>	0.88 mm	4 mm	0.25-0.52 mm <sup>2</sup>	1.13 mm	4 mm	0.33-0.82 mm <sup>2</sup>	1.34 mm	4 mm
Wire gauge	Ø	Stripping length																	
0.09-0.25 mm <sup>2</sup>	0.64 mm	4 mm																	
0.13-0.33 mm <sup>2</sup>	0.88 mm	4 mm																	
0.25-0.52 mm <sup>2</sup>	1.13 mm	4 mm																	
0.33-0.82 mm <sup>2</sup>	1.34 mm	4 mm																	

Number of contacts

**5**

Screw termination  
Unshielded

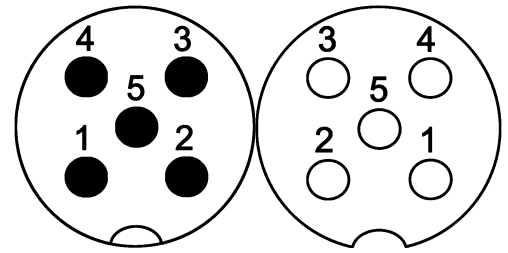

### Technical characteristics

Number of contacts	5
Rated current	7.5 A
Rated voltage	60 V
Rated impulse voltage	1.5 kV
Pollution degree	3
Insulation resistance	>10 <sup>8</sup> Ω
Contact resistance	≤10 mΩ
Mating cycles	≥100
Locking type	Screw locking
Degree of protection acc. to IEC 60529	IP67, when mated
Conductor cross-section	1.5 mm <sup>2</sup> max.
Conductor cross-section	AWG 16

### Technical characteristics

Cable diameter	4 ... 8 mm
Tightening torque	0.6 Nm
Material (insert)	Polyamide (PA)
Material (hood/housing)	Polyamide (PA), Zinc die-cast
Material (contacts)	Brass
Surface (contacts)	Gold plated
RoHS	compliant, compliant with exemption

### Specifications and approvals

IEC 61076-2-101

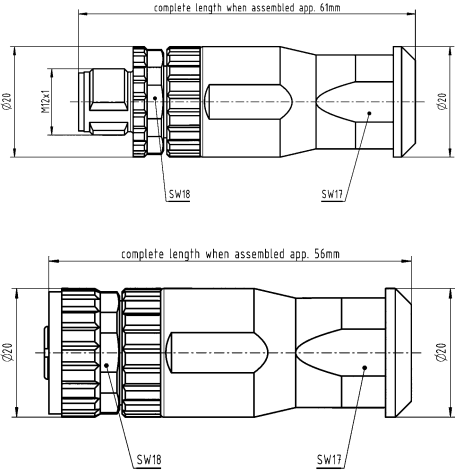
Identification	Conductor cross-section (mm <sup>2</sup> )	Part number		Drawing (dimensions in mm)
		Male	Female	
Circular connectors M12, Cable connector, Straight, Screw termination, Unshielded 	1.5 max.	21 03 319 1501	21 03 319 2501	

Identification	Conductor cross-section (mm <sup>2</sup> )	Part number		Drawing (dimensions in mm)
		Male	Female	
Circular connectors M12, Cable connector, Angled, Screw termination, Unshielded	1.5 max.	21 03 319 3501	21 03 319 4501	

M12

Number of contacts

**5**

Screw termination  
Shielded

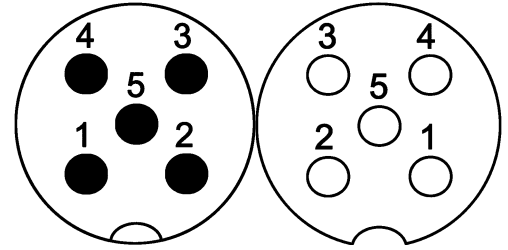

### Technical characteristics

Number of contacts	5
Rated current	4 A
Rated voltage	60 V
Rated impulse voltage	1.5 kV
Pollution degree	3
Insulation resistance	>10 <sup>8</sup> Ω
Contact resistance	≤10 mΩ
Mating cycles	≥100
Locking type	Screw locking
Degree of protection acc. to IEC 60529	IP67, when mated
Conductor cross-section	1.5 mm <sup>2</sup> max.
Conductor cross-section	AWG 16

### Technical characteristics

Cable diameter	4 ... 8 mm
Tightening torque	0.6 Nm
Material (insert)	Polyamide (PA)
Material (hood/housing)	Zinc die-cast
Material (contacts)	Brass
Surface (contacts)	Gold plated
RoHS	compliant with exemption

### Specifications and approvals

IEC 61076-2-101

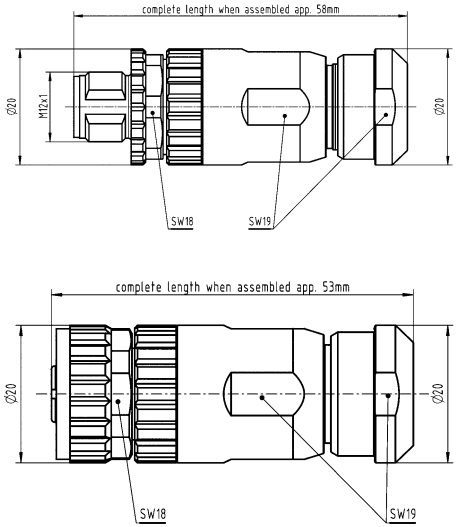
Identification	Conductor cross-section (mm <sup>2</sup> )	Part number		Drawing (dimensions in mm)
		Male	Female	
Circular connectors M12, Cable connector, Straight, Screw termination, Shielded 	1.5 max.	21 03 329 1501	21 03 329 2501	

Number of contacts

8

IDC termination  
Shielded

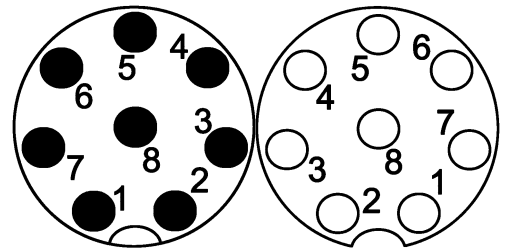

M12

Technical characteristics

Number of contacts	8
Rated current	2 A
Rated voltage	30 V
Rated impulse voltage	0.8 kV
Pollution degree	3
Insulation resistance	>10 <sup>8</sup> Ω
Contact resistance	≤10 mΩ
Mating cycles	≥100
Wire outer diameter	≤1.6 mm
Locking type	Screw locking
Degree of protection acc. to IEC 60529	IP65 / IP67, when mated
Conductor cross-section	0.14 ... 0.34 mm <sup>2</sup>
Conductor cross-section	AWG 26 ... AWG 22

Technical characteristics

Cable diameter	4 ... 8 mm
Tightening torque	0.4 Nm
Material (insert)	Polyamide (PA)
Material (hood/housing)	Zinc die-cast
Material (contacts)	Brass
Surface (contacts)	Gold plated
RoHS	compliant, compliant with exemption

Specifications and approvals

IEC 61076-2-101

Identification	Conductor cross-section (mm <sup>2</sup> )	Part number		Drawing (dimensions in mm)
		Male	Female	
Circular connectors M12, M12-L, Cable connector, Straight, IDC termination, Shielded 	0.14 ... 0.34	21 03 121 1801	21 03 121 2801	

Number of contacts

8

Screw termination  
Unshielded

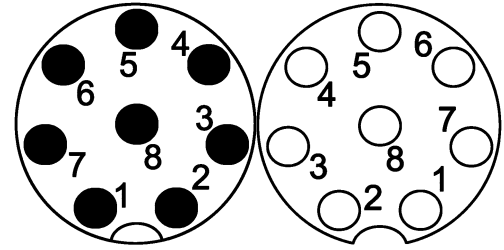

### Technical characteristics

Number of contacts	8
Rated current	2 A
Rated voltage	30 V
Rated impulse voltage	0.8 kV
Pollution degree	3
Insulation resistance	>10 <sup>8</sup> Ω
Contact resistance	≤10 mΩ
Mating cycles	≥100
Locking type	Screw locking
Degree of protection acc. to IEC 60529	IP67, when mated
Conductor cross-section	0.5 mm <sup>2</sup> max.
Conductor cross-section	AWG 20

### Technical characteristics

Cable diameter	4 ... 8 mm
Tightening torque	0.6 Nm
Material (insert)	Polyamide (PA)
Material (hood/housing)	Polyamide (PA), Zinc die-cast
Material (contacts)	Brass
Surface (contacts)	Gold plated
RoHS	compliant with exemption

### Specifications and approvals

IEC 61076-2-101

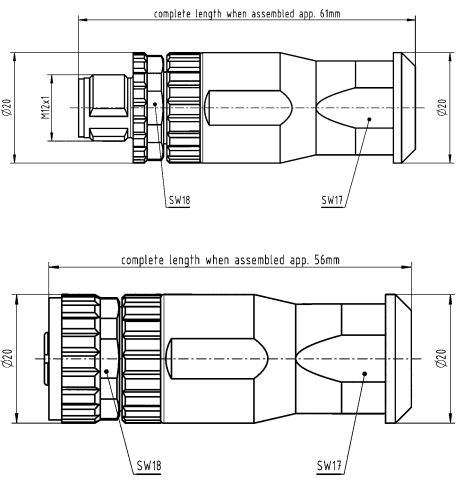
Identification	Conductor cross-section (mm <sup>2</sup> )	Part number		Drawing (dimensions in mm)
		Male	Female	
Circular connectors M12, Cable connector, Straight, Screw termination, Unshielded 	0.5 max.	21 03 319 1801	21 03 319 2801	

Identification	Conductor cross-section (mm <sup>2</sup> )	Part number		Drawing (dimensions in mm)
		Male	Female	
Circular connectors M12, Cable connector, Angled, Screw termination, Unshielded	0.5 max.	21 03 319 3801	21 03 319 4801	

M12

Number of contacts

8

Screw termination  
Shielded

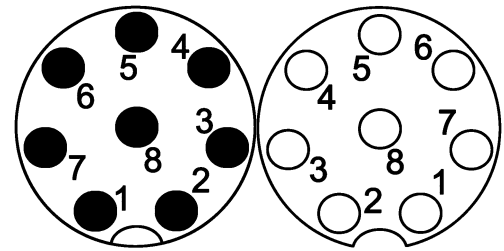

### Technical characteristics

Number of contacts	8
Rated current	2 A
Rated voltage	30 V
Rated impulse voltage	0.8 kV
Pollution degree	3
Insulation resistance	>10 <sup>8</sup> Ω
Contact resistance	≤10 mΩ
Mating cycles	≥100
Locking type	Screw locking
Degree of protection acc. to IEC 60529	IP67, when mated
Conductor cross-section	0.5 mm <sup>2</sup> max.
Conductor cross-section	AWG 20

### Technical characteristics

Cable diameter	4 ... 8 mm
Tightening torque	0.6 Nm
Material (insert)	Polyamide (PA)
Material (hood/housing)	Zinc die-cast
Material (contacts)	Brass
Surface (contacts)	Gold plated
RoHS	compliant with exemption

### Specifications and approvals

IEC 61076-2-101

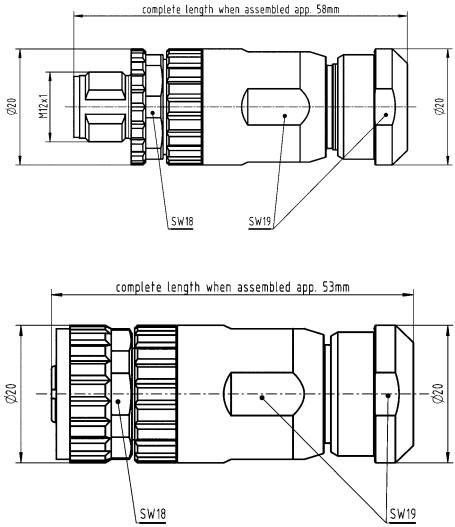
Identification	Conductor cross-section (mm <sup>2</sup> )	Part number		Drawing (dimensions in mm)
		Male	Female	
Circular connectors M12, Cable connector, Straight, Screw termination, Shielded 	0.5 max.	21 03 329 1801	21 03 329 2801	

Number of contacts

2

HARAX® connection technology  
Shielded

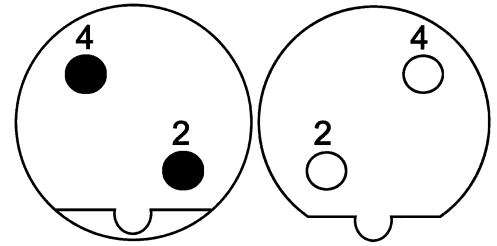

M12

### Technical characteristics

Number of contacts	2
Rated current	4 A
Rated voltage	32 V
Rated impulse voltage	1.5 kV
Pollution degree	3
Insulation resistance	>10 <sup>8</sup> Ω
Contact resistance	≤10 mΩ
Mating cycles	≥100
Wire outer diameter	≤2.6 mm
Locking type	Screw locking
Degree of protection acc. to IEC 60529	IP65 / IP67, when mated
Conductor cross-section	0.25 ... 0.34 mm <sup>2</sup>
Conductor cross-section	AWG 24 ... AWG 22

### Technical characteristics

Cable diameter	4.5 ... 8.8 mm, 7 ... 8.8 mm
Tightening torque	0.6 Nm, 2 Nm Lock nut
Material (insert)	Polyamide (PA)
Material (hood/housing)	Zinc die-cast
Material (contacts)	Brass
Surface (contacts)	Gold plated
RoHS	compliant with exemption

### Specifications and approvals

IEC 61076-2-101  
UL 1977 ECBT2.E102079  
CSA-C22.2 No. 182.3 ECBT8.E102079

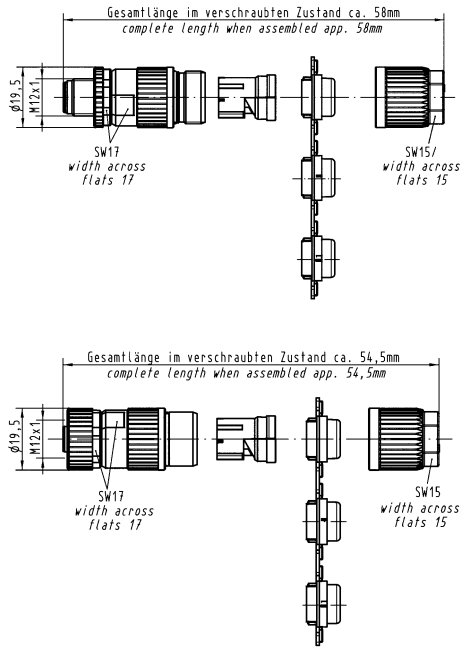
Identification	Conductor cross-section (mm <sup>2</sup> )	Part number		Drawing (dimensions in mm)
		Male	Female	
Circular connectors M12, M12-L, Cable connector, Straight, HARAX® connection technology, Shielded 	0.25 ... 0.34	21 03 241 1301	21 03 241 2301	

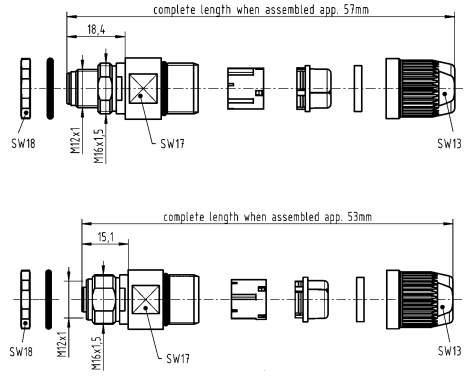
Identification	Conductor cross-section (mm <sup>2</sup> )	Part number		Drawing (dimensions in mm)
		Male	Female	
<p>Circular connectors M12, M12-L, Cable connector, Panel feed through, for rear mounting, HARAX® connection technology, Shielded, Cable-Ø 7 ... 8.8 mm</p> 	0.25 ... 0.34	21 03 341 1425	21 03 341 2425	

Number of contacts

**5**

Crimp termination  
Shielded

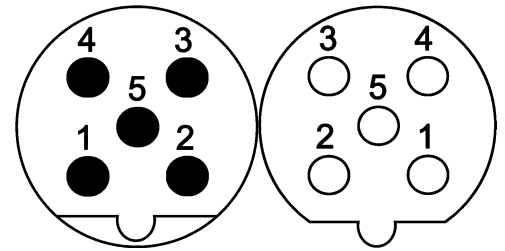

M12

### Technical characteristics

Number of contacts	5
Rated current	4 A
Rated voltage	60 V
Rated impulse voltage	1.5 kV
Pollution degree	3
Insulation resistance	>10 <sup>8</sup> Ω
Contact resistance	≤10 mΩ
Mating cycles	≥500
Wire outer diameter	≤2.3 mm
Locking type	Screw locking
Degree of protection acc. to IEC 60529	IP65 / IP67, when mated
Conductor cross-section	0.14 ... 0.75 mm <sup>2</sup> , 0.09 ... 0.25 mm <sup>2</sup> , 0.13 ... 0.33 mm <sup>2</sup> , 0.25 ... 0.52 mm <sup>2</sup> , 0.33 ... 0.82 mm <sup>2</sup>

### Technical characteristics

Conductor cross-section	AWG 26 ... AWG 18, AWG 28 ... AWG 24, AWG 26 ... AWG 22, AWG 24 ... AWG 20, AWG 22 ... AWG 18
Cable diameter	4.5 ... 8.8 mm
Tightening torque	0.6 Nm, 2 Nm Lock nut
Material (insert)	Polyamide (PA)
Material (hood/housing)	Zinc die-cast
Material (contacts)	Copper alloy
RoHS	compliant, compliant with exemption

### Specifications and approvals

IEC 61076-2-101  
UL 1977 ECBT2.E102079  
CSA-C22.2 No. 182.3 ECBT8.E102079

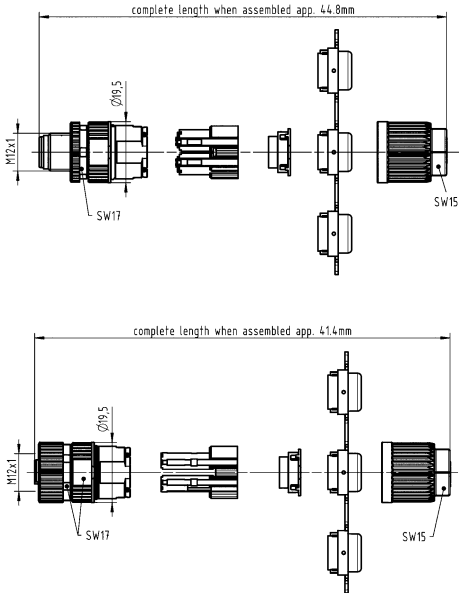
Identification	Conductor cross-section (mm <sup>2</sup> )	Part number		Drawing (dimensions in mm)
		Male	Female	
Circular connectors M12, Cable connector, Straight, Crimp termination, Shielded   Please order crimp contacts separately.	0.14 ... 0.75	21 03 841 1505	21 03 841 2505	

M12

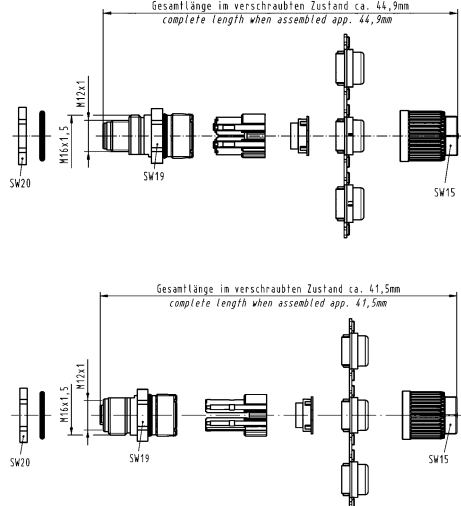
Identification	Conductor cross-section (mm <sup>2</sup> )	Part number		Drawing (dimensions in mm)
		Male	Female	
Circular connectors M12, Cable connector, Panel feed through, for rear mounting, Crimp termination, Shielded    Please order crimp contacts separately.	0.14 ... 0.75	21 03 841 1525	21 03 841 2525	 <p>Gesamtlänge im verschraubten Zustand ca. 44,9mm complete length when assembled ca. 44,9mm</p> <p>Gesamtlänge im verschraubten Zustand ca. 41,5mm complete length when assembled app. 41,5mm</p>

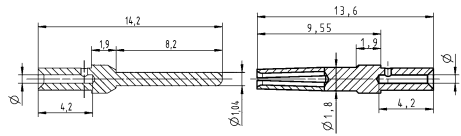
D-Sub, Standard, Crimp contact, Turned contacts  	0.09 ... 0.25	09 67 000 7576	09 67 000 7476	 <table border="1"> <thead> <tr> <th>Wire gauge</th> <th>∅</th> <th>Stripping length</th> </tr> </thead> <tbody> <tr> <td>0.09-0.25 mm<sup>2</sup></td> <td>0.64 mm</td> <td>4 mm</td> </tr> <tr> <td>0.13-0.33 mm<sup>2</sup></td> <td>0.88 mm</td> <td>4 mm</td> </tr> <tr> <td>0.25-0.52 mm<sup>2</sup></td> <td>1.13 mm</td> <td>4 mm</td> </tr> <tr> <td>0.33-0.82 mm<sup>2</sup></td> <td>1.34 mm</td> <td>4 mm</td> </tr> </tbody> </table> <p>for stranded wire according IEC 60228 Class 5</p>	Wire gauge	∅	Stripping length	0.09-0.25 mm <sup>2</sup>	0.64 mm	4 mm	0.13-0.33 mm <sup>2</sup>	0.88 mm	4 mm	0.25-0.52 mm <sup>2</sup>	1.13 mm	4 mm	0.33-0.82 mm <sup>2</sup>	1.34 mm	4 mm
	Wire gauge	∅	Stripping length																
	0.09-0.25 mm <sup>2</sup>	0.64 mm	4 mm																
	0.13-0.33 mm <sup>2</sup>	0.88 mm	4 mm																
	0.25-0.52 mm <sup>2</sup>	1.13 mm	4 mm																
0.33-0.82 mm <sup>2</sup>	1.34 mm	4 mm																	
0.13 ... 0.33	09 67 000 5576	09 67 000 5476																	
0.25 ... 0.52	09 67 000 8576	09 67 000 8476																	
0.33 ... 0.82	09 67 000 3576	09 67 000 3476																	

Number of contacts

**5**

Screw termination  
Shielded

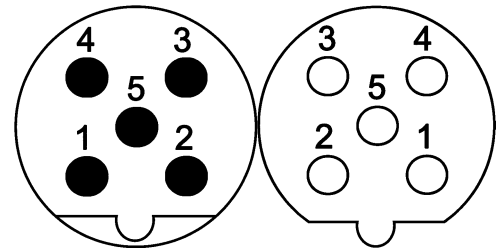

M12

### Technical characteristics

Number of contacts	5
Rated current	4 A
Rated voltage	60 V
Rated impulse voltage	1.5 kV
Pollution degree	3
Insulation resistance	>10 <sup>8</sup> Ω
Contact resistance	≤10 mΩ
Mating cycles	≥100
Locking type	Screw locking
Degree of protection acc. to IEC 60529	IP67, when mated
Conductor cross-section	1.5 mm <sup>2</sup> max.
Conductor cross-section	AWG 16

### Technical characteristics

Cable diameter	4 ... 8 mm
Tightening torque	0.6 Nm
Material (insert)	Polyamide (PA)
Material (hood/housing)	Zinc die-cast
Material (contacts)	Brass
Surface (contacts)	Gold plated
RoHS	compliant with exemption

### Specifications and approvals

IEC 61076-2-101

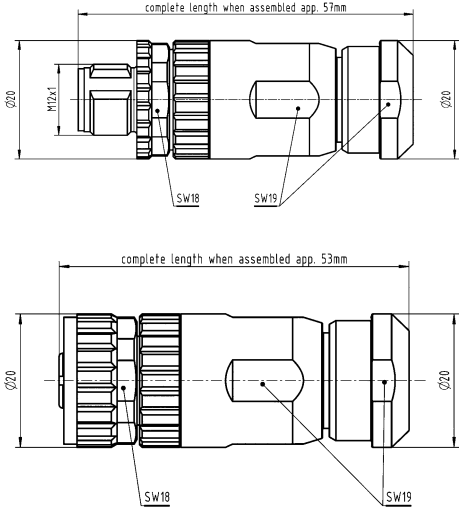
Identification	Conductor cross-section (mm <sup>2</sup> )	Part number		Drawing (dimensions in mm)
		Male	Female	
Circular connectors M12, Cable connector, Straight, Screw termination, Shielded 	1.5 max.	21 03 349 1501	21 03 349 2501	

Number of contacts

**4**

HARAX® connection technology  
Shielded

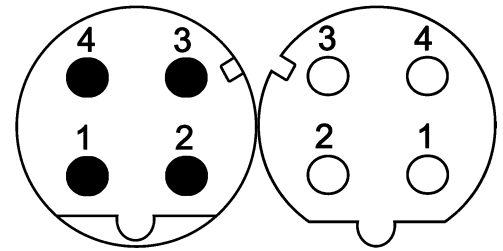

### Technical characteristics

Number of contacts	4
Rated current	4 A
Rated voltage	50 V
Rated impulse voltage	1.5 kV
Pollution degree	3
Insulation resistance	>10 <sup>8</sup> Ω
Contact resistance	≤10 mΩ
Mating cycles	≥100
Wire outer diameter	≤2 mm
Locking type	Screw locking
Degree of protection acc. to IEC 60529	IP65 / IP67, when mated
Conductor cross-section	0.14 ... 0.34 mm <sup>2</sup> , 0.34 ... 0.75 mm <sup>2</sup>
Conductor cross-section	AWG 26 ... AWG 22, AWG 22 ... AWG 18
Cable diameter	4.5 ... 8.8 mm
Transmission characteristics	Cat. 5, Class D up to 100 MHz
Tightening torque	0.6 Nm, 2 Nm Lock nut
Material (insert)	Polyamide (PA)

### Technical characteristics

Material (hood/housing)	Zinc die-cast
Material (contacts)	Brass
Surface (contacts)	Gold plated
RoHS	compliant with exemption

### Specifications and approvals

IEC 61076-2-101  
UL 1977 ECBT2.E102079  
CSA-C22.2 No. 182.3 ECBT8.E102079



### Details

For Fast Ethernet applications only

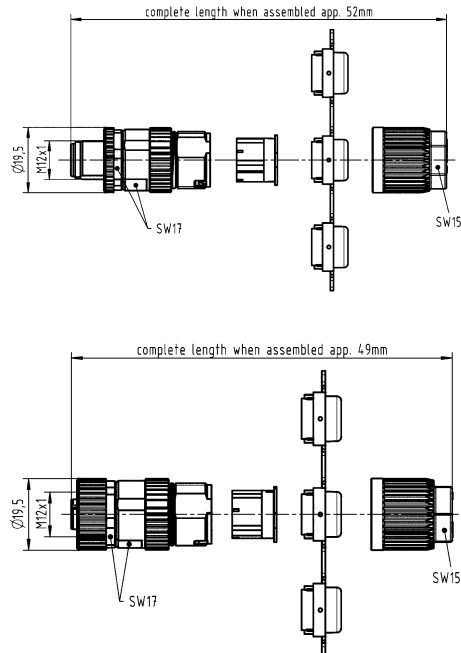
Identification	Conductor cross-section (mm <sup>2</sup> )	Part number		Drawing (dimensions in mm)
		Male	Female	
Circular connectors M12, M12-L, Cable connector, Straight, HARAX® connection technology, Shielded 	0.14 ... 0.34 0.34 ... 0.75	21 03 281 1405 21 03 282 1405	21 03 281 2405 21 03 282 2405	

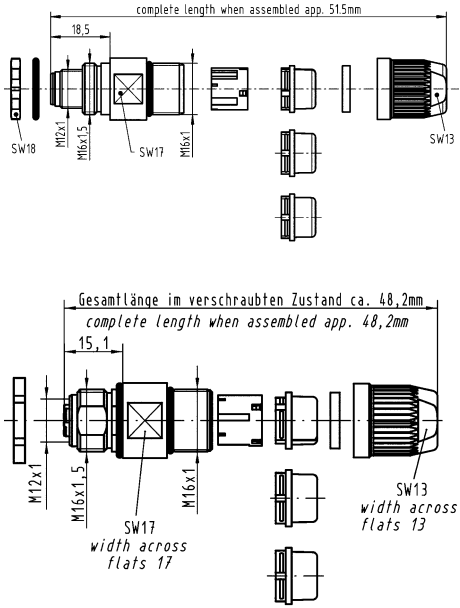
Identification	Conductor cross-section (mm <sup>2</sup> )	Part number		Drawing (dimensions in mm)
		Male	Female	
<p>Circular connectors M12, M12-L, Cable connector, Panel feed through, for rear mounting, HARAX® connection technology, Shielded</p> 	0.14 ... 0.34	21 03 381 1425	21 03 381 2425	 <p>complete length when assembled app. 51,5mm</p> <p>18,5</p> <p>SW18</p> <p>M12x1</p> <p>M16x1,5</p> <p>SW17</p> <p>M16x1</p> <p>SW13</p> <p>Gesamtlänge im verschraubten Zustand ca. 48,2mm</p> <p>complete length when assembled app. 48,2mm</p> <p>15,1</p> <p>M12x1</p> <p>M16x1,5</p> <p>SW17</p> <p>M16x1</p> <p>width across flats 17</p> <p>SW13</p> <p>width across flats 13</p>

M12

Number of contacts

**4**

Crimp termination  
Shielded

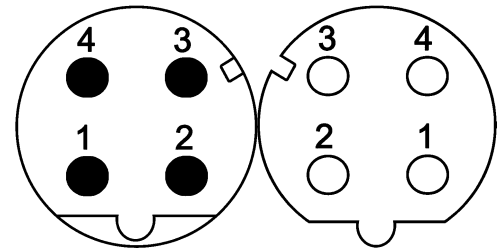

### Technical characteristics

Number of contacts	4
Rated current	4 A
Rated impulse voltage	1.5 kV
Pollution degree	3
Rated voltage	48 V AC, 60 V DC
Insulation resistance	>10 <sup>8</sup> Ω
Contact resistance	≤10 mΩ
Mating cycles	≥500
Wire outer diameter	≤2.3 mm
Locking type	Screw locking
Degree of protection acc. to IEC 60529	IP65 / IP67, when mated
Conductor cross-section	0.14 ... 0.75 mm <sup>2</sup> , 0.09 ... 0.25 mm <sup>2</sup> , 0.13 ... 0.33 mm <sup>2</sup> , 0.25 ... 0.52 mm <sup>2</sup> , 0.33 ... 0.82 mm <sup>2</sup>
Conductor cross-section	AWG 26 ... AWG 18, AWG 28 ... AWG 24, AWG 26 ... AWG 22, AWG 24 ... AWG 20, AWG 22 ... AWG 18

### Technical characteristics

Cable diameter	4.5 ... 8.8 mm
Transmission characteristics	Cat. 5, Class D up to 100 MHz
Tightening torque	0.6 Nm
Material (insert)	Polyamide (PA)
Material (hood/housing)	Zinc die-cast
Material (contacts)	Copper alloy
RoHS	compliant with exemption

### Specifications and approvals

IEC 61076-2-101  
UL 1977 ECBT2.E102079  
CSA-C22.2 No. 182.3 ECBT8.E102079

### Details

For Fast Ethernet applications only

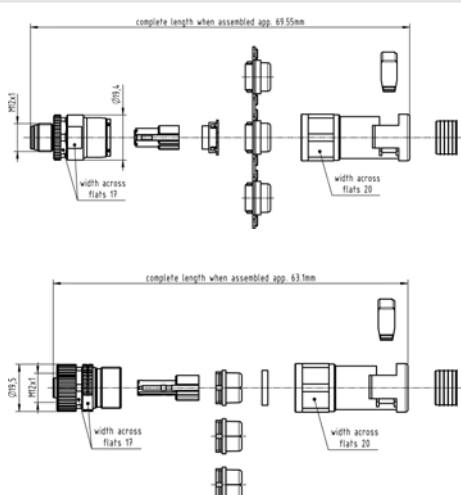
Identification	Conductor cross-section (mm <sup>2</sup> )	Part number		Drawing (dimensions in mm)
		Male	Female	
Circular connectors M12, Cable connector, with conduit, Straight, Crimp termination, Shielded   Please order crimp contacts separately.	0.14 ... 0.75	21 03 882 1411	21 03 882 2411	

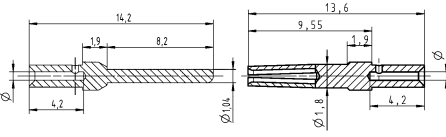
Identification	Conductor cross-section (mm <sup>2</sup> )	Part number		Drawing (dimensions in mm)															
		Male	Female																
D-Sub, Standard, Crimp contact, Turned contacts 	0.09 ... 0.25	09 67 000 7576	09 67 000 7476	 <table border="1"> <thead> <tr> <th>Wire gauge</th> <th>ø</th> <th>Stripping length</th> </tr> </thead> <tbody> <tr> <td>0.09-0.25 mm<sup>2</sup></td> <td>0.64 mm</td> <td>4 mm</td> </tr> <tr> <td>0.13-0.33 mm<sup>2</sup></td> <td>0.88 mm</td> <td>4 mm</td> </tr> <tr> <td>0.25-0.52 mm<sup>2</sup></td> <td>1.13 mm</td> <td>4 mm</td> </tr> <tr> <td>0.33-0.82 mm<sup>2</sup></td> <td>1.34 mm</td> <td>4 mm</td> </tr> </tbody> </table> <p>for stranded wire according IEC 60228 Class 5</p>	Wire gauge	ø	Stripping length	0.09-0.25 mm <sup>2</sup>	0.64 mm	4 mm	0.13-0.33 mm <sup>2</sup>	0.88 mm	4 mm	0.25-0.52 mm <sup>2</sup>	1.13 mm	4 mm	0.33-0.82 mm <sup>2</sup>	1.34 mm	4 mm
	Wire gauge	ø	Stripping length																
	0.09-0.25 mm <sup>2</sup>	0.64 mm	4 mm																
	0.13-0.33 mm <sup>2</sup>	0.88 mm	4 mm																
0.25-0.52 mm <sup>2</sup>	1.13 mm	4 mm																	
0.33-0.82 mm <sup>2</sup>	1.34 mm	4 mm																	
0.13 ... 0.33	09 67 000 5576	09 67 000 5476																	
0.25 ... 0.52	09 67 000 8576	09 67 000 8476																	
0.33 ... 0.82	09 67 000 3576	09 67 000 3476																	

Number of contacts

**4**

Screw termination  
Shielded

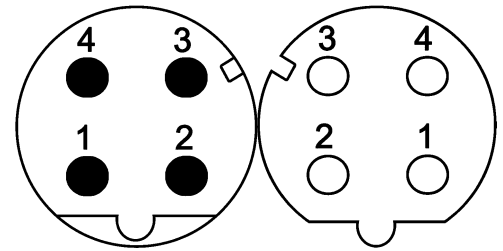

### Technical characteristics

Number of contacts	4
Rated current	4 A
Rated voltage	250 V
Rated impulse voltage	1.5 kV
Pollution degree	3
Insulation resistance	>10 <sup>8</sup> Ω
Contact resistance	≤10 mΩ
Mating cycles	≥100
Locking type	Screw locking
Degree of protection acc. to IEC 60529	IP67, when mated
Conductor cross-section	1.5 mm <sup>2</sup> max.
Conductor cross-section	AWG 16
Cable diameter	4 ... 8 mm
Transmission characteristics	Cat. 5, Class D up to 100 MHz
Tightening torque	0.6 Nm

### Technical characteristics

Material (insert)	Polyamide (PA)
Material (hood/housing)	Zinc die-cast
Material (contacts)	Brass
Surface (contacts)	Gold plated
RoHS	compliant with exemption

### Specifications and approvals

IEC 61076-2-101

### Details

For Fast Ethernet applications only

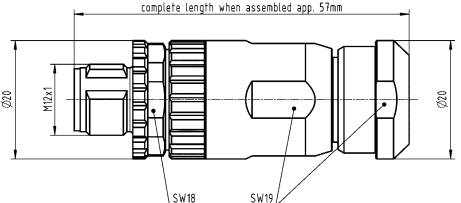
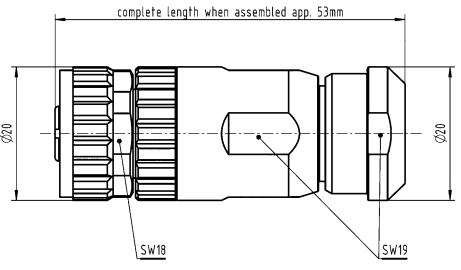
Identification	Conductor cross-section (mm <sup>2</sup> )	Part number		Drawing (dimensions in mm)
		Male	Female	
Circular connectors M12, Cable connector, Straight, Screw termination, Shielded, IP67 	1.5 max.	21 03 389 1402	21 03 389 2402	 

Number of contacts

4

Screw termination  
Shielded

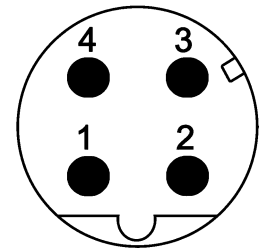

M12

### Technical characteristics

Number of contacts	4
Rated current	4 A
Rated voltage	250 V
Rated impulse voltage	1.5 kV
Pollution degree	3
Insulation resistance	>10 <sup>8</sup> Ω
Contact resistance	≤10 mΩ
Mating cycles	≥100
Locking type	Screw locking
Degree of protection acc. to IEC 60529	IP65, when mated
Conductor cross-section	1.5 mm <sup>2</sup> max.
Conductor cross-section	AWG 16
Cable diameter	4.5 ... 8.3 mm
Transmission characteristics	Cat. 5, Class D up to 100 MHz
Tightening torque	0.6 Nm

### Technical characteristics

Material (insert)	Polyamide (PA)
Material (hood/housing)	Zinc die-cast
Material (contacts)	Brass
Surface (contacts)	Gold plated

### Specifications and approvals

IEC 61076-2-101  
UL 1977 ECBT2.E102079  
CSA-C22.2 No. 182.3 ECBT8.E102079

### Details

For Fast Ethernet applications only

Identification	Conductor cross-section (mm <sup>2</sup> )	Part number Male	Drawing (dimensions in mm)
Circular connectors M12, Cable connector, Angled, Screw termination, Shielded, IP65  	1.5 max.	21 43 786 3401	

Number of contacts

4

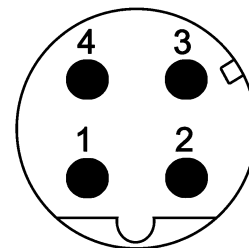
preLink® IDC insulation displacement termination  
Shielded

## Technical characteristics

Number of contacts	4
Limiting temperature	-40 ... +85 °C
Mating cycles	≥500
Locking type	Screw locking
Degree of protection acc. to IEC 60529	IP65, IP67
Conductor cross-section	0.1 ... 0.12 mm <sup>2</sup> , 0.22 ... 0.32 mm <sup>2</sup>
Conductor cross-section	AWG 27 ... AWG 26, AWG 24 ... AWG 22
Cable diameter	5 ... 9.5 mm
Transmission characteristics	Cat. 5, Class D up to 100 MHz
Data rate	10 Mbit/s, 100 Mbit/s
Material (hood/housing)	Zinc die-cast
Surface (hood/housing)	Nickel plated
RoHS	compliant with exemption

## Specifications and approvals

UL 1863 DUXR2.E470046  
CSA-C22.2 No. 182.4, No. 233-09 DUXR8.E470046  
DNV GL



## Details

For Fast Ethernet applications only

Identification	Conductor cross-section (mm <sup>2</sup> )	Part number Male	Drawing (dimensions in mm)
preLink®, Circular connectors M12, Screw mounted housing, Cable connector, preLink® IDC insulation displacement termination, Shielded    Please order terminal module separately	0.1 ... 0.12, 0.22 ... 0.32	20 82 005 0001	

Number of contacts

4

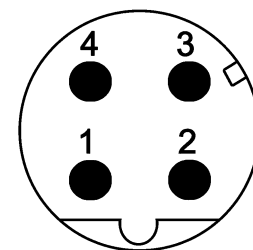
preLink® IDC insulation displacement termination  
Shielded

M12

## Technical characteristics

Number of contacts	4
Limiting temperature	-40 ... +85 °C
Mating cycles	≥500
Locking type	Screw locking
Degree of protection acc. to IEC 60529	IP65, IP67
Conductor cross-section	0.1 ... 0.12 mm <sup>2</sup> , 0.22 ... 0.32 mm <sup>2</sup>
Conductor cross-section	AWG 27 ... AWG 26, AWG 24 ... AWG 22
Cable diameter	5 ... 9.5 mm
Transmission characteristics	Cat. 5, Class D up to 100 MHz
Data rate	10 Mbit/s, 100 Mbit/s
Material (insert)	Zinc die-cast, nickel-plated
Material (hood/housing)	Zinc die-cast
RoHS	compliant with exemption, compliant



## Specifications and approvals

UL 1863 DUXR2.E470046  
CSA-C22.2 No. 182.4, No. 233-09 DUXR8.E470046  
DNV GL



## Details

For Fast Ethernet applications only

Identification	Conductor cross-section (mm <sup>2</sup> )	Part number Male	Drawing (dimensions in mm)
preLink®, Circular connectors M12, Connector insert, preLink® IDC insulation displacement termination, Shielded   Please order terminal module separately Please order screw mounted housing separately.	0.1 ... 0.12, 0.22 ... 0.32	20 82 005 1214	
preLink®, Circular connectors M12, Screw mounted housing, Empty housing  	0.1 ... 0.12, 0.22 ... 0.32	20 82 000 1210	

Number of contacts

4

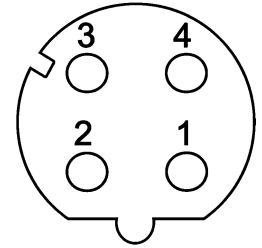
preLink® IDC insulation displacement termination  
Shielded

## Features

- Ethernet data connector suitable for industry
- Robust design
- 360° shielding
- Category of transmission Cat. 5
- Suitable for termination of massive and flexible wires
- Suitable for all PoE versions
- Very fast preLink® termination technology

## Technical characteristics

Number of contacts	4
Limiting temperature	-40 ... +85 °C
Mating cycles	≥500
Locking type	Screw locking, PushPull
Degree of protection acc. to IEC 60529	IP65, IP67
Conductor cross-section	0.1 ... 0.12 mm <sup>2</sup> , 0.22 ... 0.32 mm <sup>2</sup>
Conductor cross-section	AWG 27 ... AWG 26, AWG 24 ... AWG 22
Cable diameter	5 ... 9.5 mm
Transmission characteristics	Cat. 5, Class D up to 100 MHz
Data rate	10 Mbit/s, 100 Mbit/s
Material (hood/housing)	Zinc die-cast
Surface (hood/housing)	Nickel plated
RoHS	compliant with exemption

## Specifications and approvals

IEC 61076-2-101  
DNV GL

## Details

For Fast Ethernet applications only

Identification	Conductor cross-section (mm <sup>2</sup> )	Part number Female	Drawing (dimensions in mm)
----------------	--	-----------------------	-------------------------------

preLink®,  
Circular connectors M12,  
Cable connector,  
Panel feed through,  
for rear mounting,  
preLink® IDC insulation displacement  
termination,  
Shielded



Please order terminal module separately

0.1 ... 0.12,  
0.22 ... 0.32

20 82 005 2001

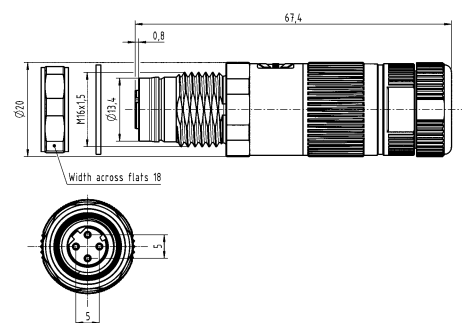

Number of contacts

8

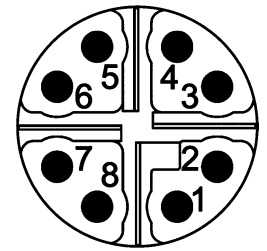
preLink® IDC insulation displacement termination  
Shielded

M12

## Technical characteristics

Number of contacts	8
Limiting temperature	-40 ... +85 °C
Mating cycles	≥500
Locking type	Screw locking
Degree of protection acc. to IEC 60529	IP65, IP67
Conductor cross-section	0.1 ... 0.12 mm <sup>2</sup> , 0.22 ... 0.32 mm <sup>2</sup>
Conductor cross-section	AWG 27 ... AWG 26, AWG 24 ... AWG 22
Cable diameter	5 ... 9.5 mm
Transmission characteristics	Cat. 6A, Class E <sub>A</sub> up to 500 MHz
Data rate	10 Mbit/s, 100 Mbit/s, 1 Gbit/s, 2.5 Gbit/s, 5 Gbit/s, 10 Gbit/s
Material (hood/housing)	Zinc die-cast
Surface (hood/housing)	Nickel plated

## Technical characteristics

RoHS compliant with exemption

## Specifications and approvals

UL 1863 DUXR2.E470046  
 CSA-C22.2 No. 182.4, No. 233-09 DUXR8.E470046  
 DNV GL



## Details

For Ethernet applications up to 10 Gbit only

Identification	Conductor cross-section (mm <sup>2</sup> )	Part number Male	Drawing (dimensions in mm)
preLink®, Circular connectors M12, Screw mounted housing, Cable connector, preLink® IDC insulation displacement termination, Shielded  <p>Please order terminal module separately</p>	0.1 ... 0.12, 0.22 ... 0.32	20 82 005 0002	

Number of contacts

8

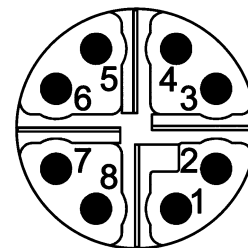
preLink® IDC insulation displacement termination  
Shielded

## Technical characteristics

Number of contacts	8
Limiting temperature	-40 ... +85 °C
Mating cycles	≥500
Locking type	Screw locking
Degree of protection acc. to IEC 60529	IP65, IP67
Conductor cross-section	0.1 ... 0.12 mm <sup>2</sup> , 0.22 ... 0.32 mm <sup>2</sup>
Conductor cross-section	AWG 27 ... AWG 26, AWG 24 ... AWG 22
Cable diameter	5 ... 9.5 mm
Transmission characteristics	Cat. 6A, Class E <sub>A</sub> up to 500 MHz
Data rate	10 Mbit/s, 100 Mbit/s, 1 Gbit/s, 2.5 Gbit/s, 5 Gbit/s, 10 Gbit/s
Material (insert)	Zinc die-cast, nickel-plated
Material (hood/housing)	Zinc die-cast

## Technical characteristics



RoHS compliant with exemption,  
compliant

## Specifications and approvals

UL 1863 DUXR2.E470046  
CSA-C22.2 No. 182.4, No. 233-09 DUXR8.E470046  
DNV GL

## Details

For Ethernet applications up to 10 Gbit only

Identification	Conductor cross-section (mm <sup>2</sup> )	Part number Male	Drawing (dimensions in mm)
preLink®, Circular connectors M12, Connector insert, preLink® IDC insulation displacement termination, Shielded   Please order terminal module separately Please order screw mounted housing separately.	0.1 ... 0.12, 0.22 ... 0.32	20 82 006 1218	
preLink®, Circular connectors M12, Screw mounted housing, Empty housing  	0.1 ... 0.12, 0.22 ... 0.32	20 82 000 1210	

Number of contacts

8

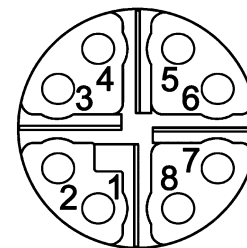
preLink® IDC insulation displacement termination  
Shielded

M12

## Features

- Ethernet data connector suitable for industry
- Robust design
- 360° shielding
- Category of transmission Cat. 6<sub>A</sub>
- Suitable for termination of massive and flexible wires
- Suitable for all PoE versions
- Very fast preLink® termination technology

## Technical characteristics

Number of contacts	8
Limiting temperature	-40 ... +85 °C
Mating cycles	≥500
Locking type	Screw locking, PushPull
Degree of protection acc. to IEC 60529	IP65, IP67
Conductor cross-section	0.1 ... 0.12 mm <sup>2</sup> , 0.22 ... 0.32 mm <sup>2</sup>
Conductor cross-section	AWG 27 ... AWG 26, AWG 24 ... AWG 22
Cable diameter	5 ... 9.5 mm
Transmission characteristics	Cat. 6 <sub>A</sub> , Class E <sub>A</sub> up to 500 MHz
Data rate	10 Mbit/s, 100 Mbit/s, 1 Gbit/s, 2.5 Gbit/s, 5 Gbit/s, 10 Gbit/s
Material (hood/housing)	Zinc die-cast
Surface (hood/housing)	Nickel plated
RoHS	compliant with exemption

## Specifications and approvals

IEC 61076-2-109  
DNV GL

## Details

For Ethernet applications up to 10 Gbit only

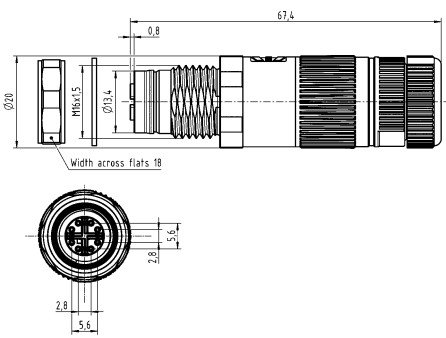
Identification	Conductor cross-section (mm <sup>2</sup> )	Part number Female	Drawing (dimensions in mm)
preLink®, Circular connectors M12, Cable connector, Panel feed through, for rear mounting, preLink® IDC insulation displacement termination, Shielded  	0.1 ... 0.12, 0.22 ... 0.32	20 82 006 2001	
Please order terminal module separately			

preLink® IDC insulation displacement termination



M12



## Technical characteristics



Limiting temperature	-40 ... +85 °C
Mating cycles	≥10
Wire outer diameter	1.3 ... 1.6 mm, 0.8 ... 1.1 mm
Conductor cross-section	0.22 ... 0.32 mm <sup>2</sup> , 0.1 ... 0.12 mm <sup>2</sup>
Conductor cross-section	AWG 24 ... AWG 22, AWG 27 ... AWG 26
Colour (insert)	Yellow, White, Black
RoHS	compliant

## Specifications and approvals

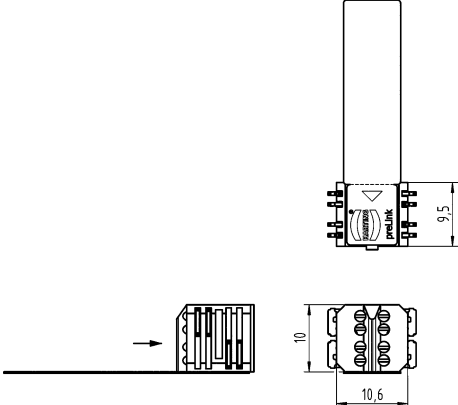
DNV GL  
 UL 1863 DUXR2.E470046  
 CSA-C22.2 No. 182.4, No. 233-09 DUXR8.E470046

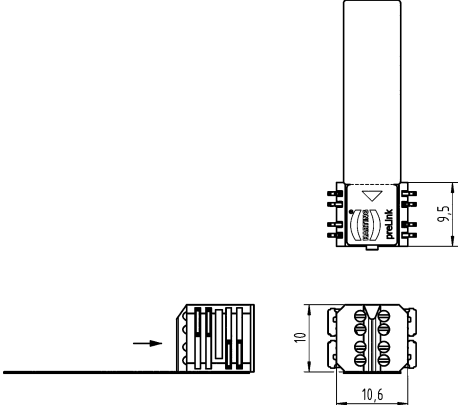

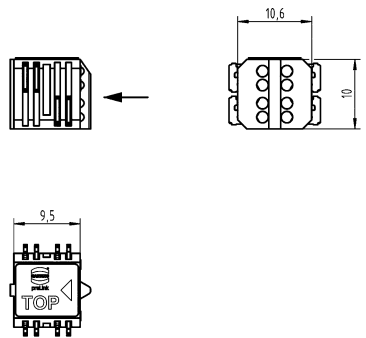
Identification	Conductor cross-section (mm <sup>2</sup> )	Part number	Drawing (dimensions in mm)
preLink®, Terminal module, 8-pins, preLink® IDC insulation displacement termination, Conductor diameter 1.3 - 1.6 mm, Pack contents: 10 pieces 	0.22 ... 0.32	20 82 000 0001	
preLink®, Terminal module, 8-pins, preLink® IDC insulation displacement termination, Conductor diameter 0.8 - 1.1 mm, Pack contents: 10 pieces 	0.1 ... 0.12	20 82 000 0003	

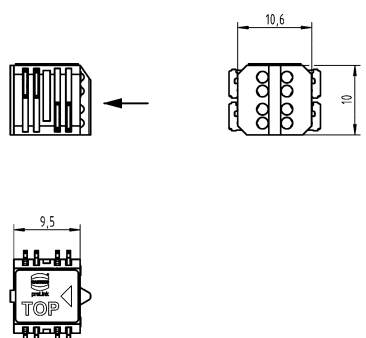
Identification	Conductor cross-section (mm <sup>2</sup> )	Part number	Drawing (dimensions in mm)
<p>preLink®, Terminal module, 4-pin, AIDA compliant, preLink® IDC insulation displacement termination, Conductor diameter 1.3 - 1.6 mm, Pack contents: 10 pieces</p> 	<p>0.22 ... 0.32</p>	<p>20 82 000 0005</p>	
<p>preLink®, Terminal module, 4-pin, AIDA compliant, preLink® IDC insulation displacement termination, Conductor diameter 1.3 - 1.6 mm, Pack contents: 100 pieces</p> 	<p>0.22 ... 0.32</p>	<p>20 82 000 0005 XL</p>	

Number of contacts

# 4

HARAX® connection technology  
Shielded

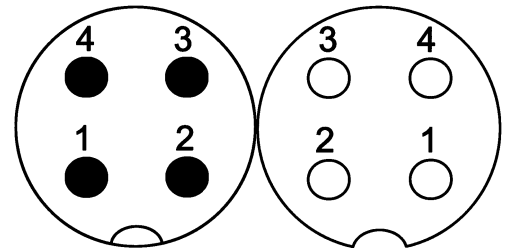

## Technical characteristics

Number of contacts	4
Rated current	4 A
Rated voltage	50 V
Rated impulse voltage	1.5 kV
Pollution degree	3
Insulation resistance	>10 <sup>8</sup> Ω
Contact resistance	≤10 mΩ
Mating cycles	≥500
Wire outer diameter	≤1.6 mm
Locking type	Screw locking
Degree of protection acc. to IEC 60529	IP65 / IP67, when mated
Conductor cross-section	0.34 mm <sup>2</sup> , 0.14 mm <sup>2</sup>
Conductor cross-section	AWG 22, AWG 26

## Technical characteristics

Cable diameter	5.7 ... 8.8 mm
Tightening torque	0.6 Nm
Material (insert)	Polyamide (PA)
Material (hood/housing)	Zinc die-cast
Material (contacts)	Copper alloy
Surface (contacts)	Gold plated
RoHS	compliant

## Specifications and approvals

IEC 61076-2-101  
UL 2238 CYJV2.E302521  
CSA-C22.2 No. 182.3 CYJV8.E302521

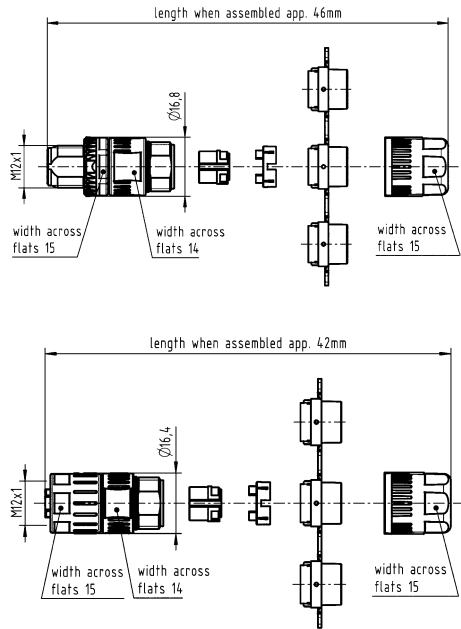
Identification	Conductor cross-section (mm <sup>2</sup> )	Part number		Drawing (dimensions in mm)
		Male	Female	
Circular connectors M12, Slim Design, Cable connector, Straight, HARAX® connection technology, Shielded 	0.14 0.34	21 03 322 1410 21 03 322 1400	21 03 322 2410 21 03 322 2400	

Number of contacts

# 5

Crimp termination  
Shielded

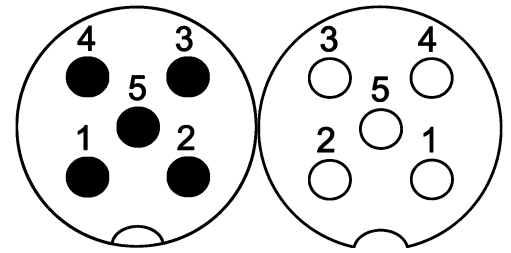

M12

## Technical characteristics

Number of contacts	5
Rated current	4 A
Rated impulse voltage	1.5 kV
Pollution degree	3
Rated voltage	48 V AC, 60 V DC
Insulation resistance	>10 <sup>8</sup> Ω
Contact resistance	≤10 mΩ
Mating cycles	≥500
Wire outer diameter	≤2.3 mm
Locking type	Screw locking, PushPull
Degree of protection acc. to IEC 60529	IP65 / IP67, when mated
Conductor cross-section	0.13 ... 0.82 mm <sup>2</sup> , 0.09 ... 0.25 mm <sup>2</sup> , 0.13 ... 0.33 mm <sup>2</sup> , 0.25 ... 0.52 mm <sup>2</sup> , 0.33 ... 0.82 mm <sup>2</sup>

## Technical characteristics





Conductor cross-section	AWG 26 ... AWG 18, AWG 28 ... AWG 24, AWG 26 ... AWG 22, AWG 24 ... AWG 20, AWG 22 ... AWG 18
Cable diameter	5.7 ... 8.8 mm
Tightening torque	0.6 Nm, 2 Nm Lock nut
Material (insert)	Liquid crystal polymer (LCP)
Material (hood/housing)	Zinc die-cast
Material (contacts)	Copper alloy
RoHS	compliant, compliant with exemption

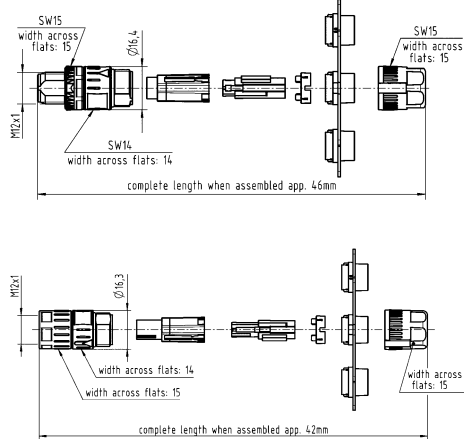

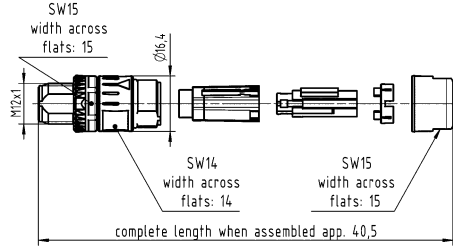
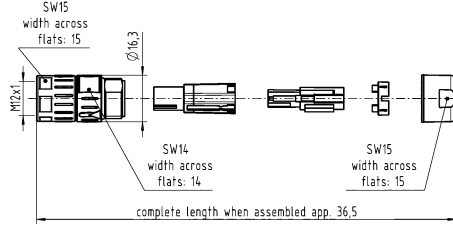

## Specifications and approvals

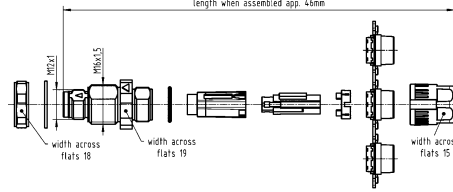
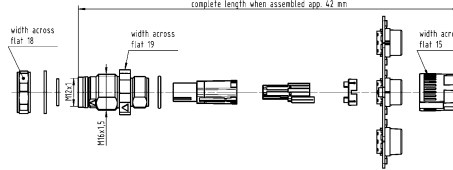
IEC 61076-2-101  
UL 2238 CYJV2.E302521  
CSA-C22.2 No. 182.3 CYJV8.E302521

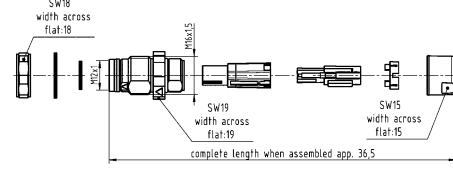
Identification	Conductor cross-section (mm <sup>2</sup> )	Part number		Drawing (dimensions in mm)
		Male	Female	
Circular connectors M12, Slim Design, Cable connector, Straight, Crimp termination, Shielded    Please order crimp contacts separately.	0.13 ... 0.82	21 03 821 1505	21 03 821 2505	

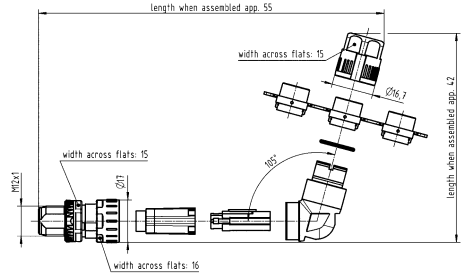
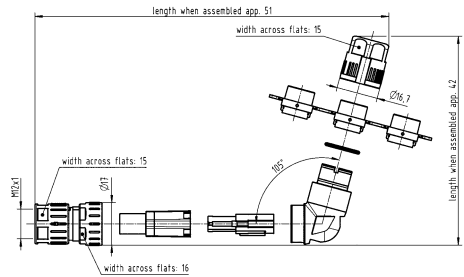
M12

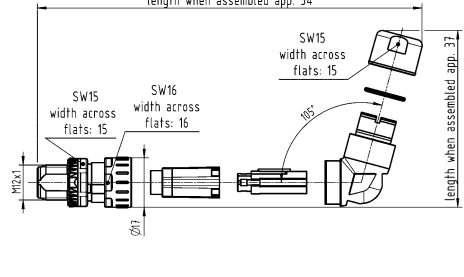
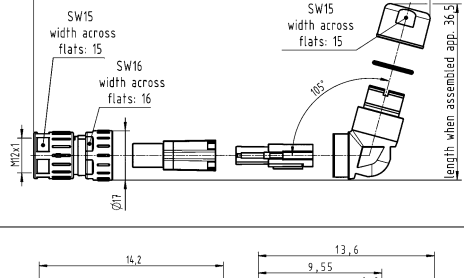
Identification	Conductor cross-section (mm <sup>2</sup> )	Part number		Drawing (dimensions in mm)
		Male	Female	
<p>Circular connectors M12, Slim Design, Cable connector, Straight, Crimp termination, Shielded, Shield connection with crimp flange</p>  <p>Please order crimp contacts separately. Please order crimp flange set separately.</p>	0.13 ... 0.82	21 03 821 1507	21 03 821 2507	 
<p>Circular connectors M12, Slim Design, Cable connector, Panel feed through, for rear mounting, Crimp termination, Shielded</p>  <p>Please order crimp contacts separately.</p>	0.13 ... 0.82	21 03 821 1525	21 03 821 2525	 
<p>Circular connectors M12, Slim Design, Cable connector, Panel feed through, for rear mounting, Crimp termination, Shielded, Shield connection with crimp flange</p>  <p>Please order crimp contacts separately. Please order crimp flange set separately.</p>	0.13 ... 0.82		21 03 821 2527	

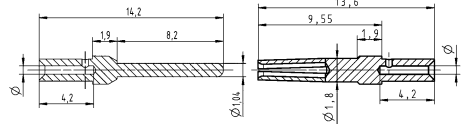
Identification	Conductor cross-section (mm <sup>2</sup> )	Part number		Drawing (dimensions in mm)															
		Male	Female																
<p>Circular connectors M12, Slim Design, Cable connector, Angled, Crimp termination, Shielded</p>  <p>Please order crimp contacts separately.</p>	0.13 ... 0.82	21 03 821 3505	21 03 821 4505	 															
<p>Circular connectors M12, Slim Design, Cable connector, Angled, Crimp termination, Shielded, Shield connection with crimp flange</p>  <p>Please order crimp contacts separately. Please order crimp flange set separately.</p>	0.13 ... 0.82	21 03 821 3507	21 03 821 4507	 															
<p>D-Sub, Standard, Crimp contact, Turned contacts</p> 	<p>0.09 ... 0.25 0.13 ... 0.33 0.25 ... 0.52 0.33 ... 0.82</p>	<p>09 67 000 7576 09 67 000 5576 09 67 000 8576 09 67 000 3576</p>	<p>09 67 000 7476 09 67 000 5476 09 67 000 8476 09 67 000 3476</p>	 <table border="1"> <thead> <tr> <th>Wire gauge</th> <th>Ø</th> <th>Stripping length</th> </tr> </thead> <tbody> <tr> <td>0.09-0.25 mm<sup>2</sup></td> <td>0.64 mm</td> <td>4 mm</td> </tr> <tr> <td>0.13-0.33 mm<sup>2</sup></td> <td>0.88 mm</td> <td>4 mm</td> </tr> <tr> <td>0.25-0.52 mm<sup>2</sup></td> <td>1.13 mm</td> <td>4 mm</td> </tr> <tr> <td>0.33-0.82 mm<sup>2</sup></td> <td>1.34 mm</td> <td>4 mm</td> </tr> </tbody> </table> <p>for stranded wire according IEC 60228 Class 5</p>	Wire gauge	Ø	Stripping length	0.09-0.25 mm <sup>2</sup>	0.64 mm	4 mm	0.13-0.33 mm <sup>2</sup>	0.88 mm	4 mm	0.25-0.52 mm <sup>2</sup>	1.13 mm	4 mm	0.33-0.82 mm <sup>2</sup>	1.34 mm	4 mm
Wire gauge	Ø	Stripping length																	
0.09-0.25 mm <sup>2</sup>	0.64 mm	4 mm																	
0.13-0.33 mm <sup>2</sup>	0.88 mm	4 mm																	
0.25-0.52 mm <sup>2</sup>	1.13 mm	4 mm																	
0.33-0.82 mm <sup>2</sup>	1.34 mm	4 mm																	

M12

Circular connectors M12, Slim Design, Crimp flange set



HARTING offers to test and define the best crimp flange and ferrule combination for customer specific cables.

Conductor cross-section (mm<sup>2</sup>)

Part number  
Male Female

Drawing (dimensions in mm)

Part number	Male	Female
21 01 010 00xx		

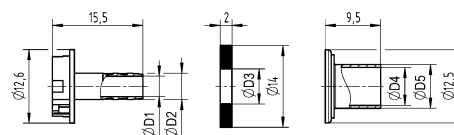

	D1	D2	D3	D4	D5
21 01 010 0017	3.5	4.5	6.0	6.5	7.5
21 01 010 0018	4.5	5.5	6.6	7.5	8.5
21 01 010 0019	4.5	5.5	6.8	8.0	9.0
21 01 010 0020	5.0	6.0	7.8	9.0	10.0
21 01 010 0021	6.5	7.5	8.0	10.0	10.8
21 01 010 0022	5.0	6.0	7.4	9.0	10.0
21 01 010 0024	5.5	6.5	8.8	10.0	10.8

Number of contacts

# 8

Crimp termination  
Shielded

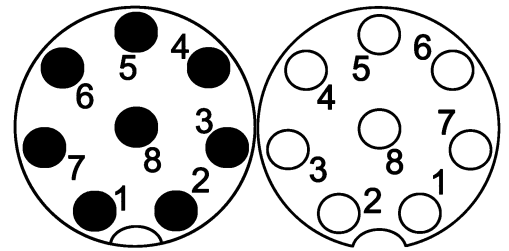

M12

## Technical characteristics

Number of contacts	8
Rated current	2 A
Rated impulse voltage	0.8 kV
Pollution degree	3
Rated voltage	30 V AC, 30 V DC
Insulation resistance	>10 <sup>8</sup> Ω
Contact resistance	≤10 mΩ
Mating cycles	≥500
Wire outer diameter	≤1.65 mm
Locking type	Screw locking, PushPull
Degree of protection acc. to IEC 60529	IP65 / IP67, when mated
Conductor cross-section	0.13 ... 0.33 mm <sup>2</sup>
Conductor cross-section	AWG 26 ... AWG 22
Cable diameter	5.7 ... 8.8 mm

## Technical characteristics





Tightening torque	0.6 Nm, 2 Nm Lock nut
Material (insert)	Liquid crystal polymer (LCP)
Material (hood/housing)	Zinc die-cast
Material (contacts)	Copper alloy
Surface (contacts)	Gold plated
RoHS	compliant, compliant with exemption

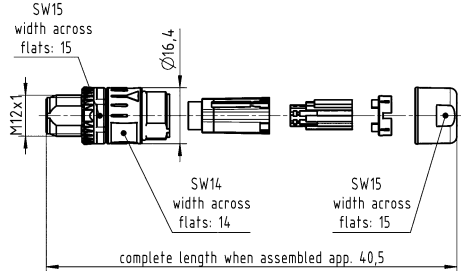
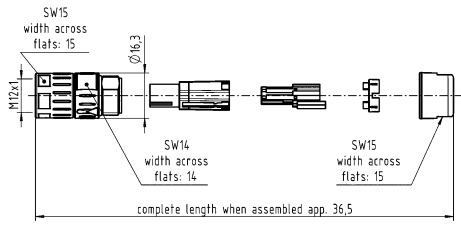

## Specifications and approvals

IEC 61076-2-101  
UL 2238 CYJV2.E302521  
CSA-C22.2 No. 182.3 CYJV8.E302521

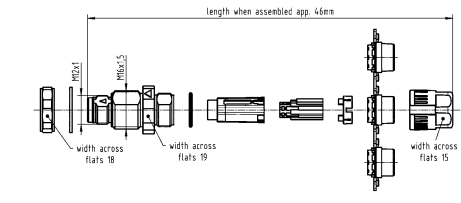
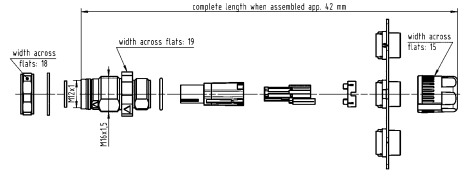
Identification	Conductor cross-section (mm <sup>2</sup> )	Part number		Drawing (dimensions in mm)
		Male	Female	
<p>Circular connectors M12, Slim Design, Cable connector, Straight, Crimp termination, Shielded</p> <p>Please order crimp contacts separately.</p>	0.13 ... 0.33	21 03 821 1805	21 03 821 2805	

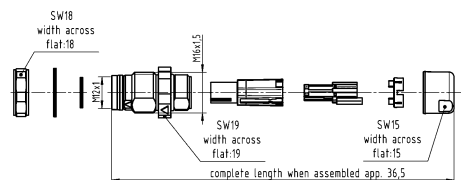
M12

Identification	Conductor cross-section (mm <sup>2</sup> )	Part number		Drawing (dimensions in mm)
		Male	Female	
<p>Circular connectors M12, Slim Design, Cable connector, Straight, Crimp termination, Shielded, Shield connection with crimp flange</p>  <p>Please order crimp contacts separately. Please order crimp flange set separately.</p>	0.13 ... 0.33	21 03 821 1807	21 03 821 2807	 
<p>Circular connectors M12, Slim Design, Cable connector, Panel feed through, for rear mounting, Crimp termination, Shielded</p>  <p>Please order crimp contacts separately.</p>	0.13 ... 0.33	21 03 821 1825	21 03 821 2825	 
<p>Circular connectors M12, Slim Design, Cable connector, Panel feed through, for rear mounting, Crimp termination, Shielded, Shield connection with crimp flange</p>  <p>Please order crimp contacts separately. Please order crimp flange set separately.</p>	0.13 ... 0.33		21 03 821 2827	

Identification	Conductor cross-section (mm <sup>2</sup> )	Part number		Drawing (dimensions in mm)
		Male	Female	
<p>Circular connectors M12, Slim Design, Cable connector, Angled, Crimp termination, Shielded</p>  <p>Please order crimp contacts separately.</p>	0.13 ... 0.33	21 03 821 3805	21 03 821 4805	
<p>Circular connectors M12, Slim Design, Cable connector, Angled, Crimp termination, Shielded, Shield connection with crimp flange</p>  <p>Please order crimp contacts separately. Please order crimp flange set separately.</p>	0.13 ... 0.33	21 03 821 3807	21 03 821 4807	
<p>Circular connectors M12, Slim Design, Cable connector, Angled, Crimp contact, Turned contacts</p> 	0.13 ... 0.33	21 01 100 9020	21 01 100 9025	

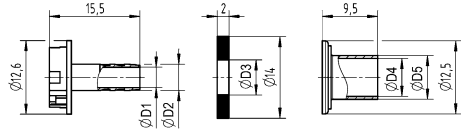
Identification	Conductor cross-section (mm <sup>2</sup> )	Part number		Drawing (dimensions in mm)																																																
		Male	Female																																																	
Circular connectors M12, Slim Design, Crimp flange set  <p>HARTING offers to test and define the best crimp flange and ferrule combination for customer specific cables.</p>		21 01 010 00xx	21 01 010 00xx	 <table border="1"> <thead> <tr> <th></th> <th>D1</th> <th>D2</th> <th>D3</th> <th>D4</th> <th>D5</th> </tr> </thead> <tbody> <tr> <td>21 01 010 0017</td> <td>3.5</td> <td>4.5</td> <td>6.0</td> <td>6.5</td> <td>7.5</td> </tr> <tr> <td>21 01 010 0018</td> <td>4.5</td> <td>5.5</td> <td>6.6</td> <td>7.5</td> <td>8.5</td> </tr> <tr> <td>21 01 010 0019</td> <td>4.5</td> <td>5.5</td> <td>6.8</td> <td>8.0</td> <td>9.0</td> </tr> <tr> <td>21 01 010 0020</td> <td>5.0</td> <td>6.0</td> <td>7.8</td> <td>9.0</td> <td>10.0</td> </tr> <tr> <td>21 01 010 0021</td> <td>6.5</td> <td>7.5</td> <td>8.0</td> <td>10.0</td> <td>10.8</td> </tr> <tr> <td>21 01 010 0022</td> <td>5.0</td> <td>6.0</td> <td>7.4</td> <td>9.0</td> <td>10.0</td> </tr> <tr> <td>21 01 010 0024</td> <td>5.5</td> <td>6.5</td> <td>8.8</td> <td>10.0</td> <td>10.8</td> </tr> </tbody> </table>		D1	D2	D3	D4	D5	21 01 010 0017	3.5	4.5	6.0	6.5	7.5	21 01 010 0018	4.5	5.5	6.6	7.5	8.5	21 01 010 0019	4.5	5.5	6.8	8.0	9.0	21 01 010 0020	5.0	6.0	7.8	9.0	10.0	21 01 010 0021	6.5	7.5	8.0	10.0	10.8	21 01 010 0022	5.0	6.0	7.4	9.0	10.0	21 01 010 0024	5.5	6.5	8.8	10.0	10.8
	D1	D2	D3	D4	D5																																															
21 01 010 0017	3.5	4.5	6.0	6.5	7.5																																															
21 01 010 0018	4.5	5.5	6.6	7.5	8.5																																															
21 01 010 0019	4.5	5.5	6.8	8.0	9.0																																															
21 01 010 0020	5.0	6.0	7.8	9.0	10.0																																															
21 01 010 0021	6.5	7.5	8.0	10.0	10.8																																															
21 01 010 0022	5.0	6.0	7.4	9.0	10.0																																															
21 01 010 0024	5.5	6.5	8.8	10.0	10.8																																															

Number of contacts

# 4

HARAX® connection technology  
Shielded

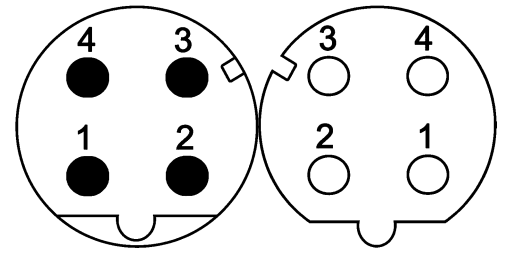

M12

## Technical characteristics

Number of contacts	4
Rated current	4 A
Rated voltage	50 V
Rated impulse voltage	1.5 kV
Pollution degree	3
Insulation resistance	>10 <sup>8</sup> Ω
Contact resistance	≤10 mΩ
Mating cycles	≥500
Wire outer diameter	≤1.6 mm
Locking type	Screw locking
Degree of protection acc. to IEC 60529	IP65 / IP67, when mated
Conductor cross-section	0.34 mm <sup>2</sup> , 0.14 mm <sup>2</sup>
Conductor cross-section	AWG 22, AWG 26
Cable diameter	5.7 ... 8.8 mm
Transmission characteristics	Cat. 5, Class D up to 100 MHz
Tightening torque	0.6 Nm
Material (insert)	Polyamide (PA)
Material (hood/housing)	Zinc die-cast

## Technical characteristics

Material (contacts)	Copper alloy
Surface (contacts)	Gold plated
RoHS	compliant

## Specifications and approvals

IEC 61076-2-101  
UL 2238 CYJV2.E302521  
CSA-C22.2 No. 182.3 CYJV8.E302521



## Details

For Fast Ethernet applications only

Identification	Conductor cross-section (mm <sup>2</sup> )	Part number		Drawing (dimensions in mm)
		Male	Female	
Circular connectors M12, Slim Design, Cable connector, Straight, HARAX® connection technology, Shielded 	0.14 0.34	21 03 382 1410 21 03 382 1400	21 03 382 2410 21 03 382 2400	

Number of contacts

# 4

Crimp termination  
Shielded

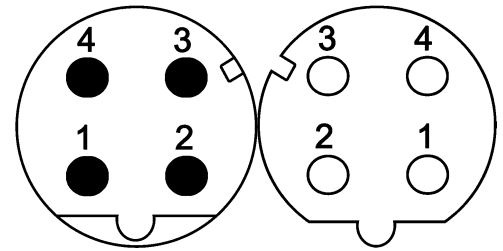

## Technical characteristics

Number of contacts	4
Rated current	4 A
Rated impulse voltage	1.5 kV
Pollution degree	3
Rated voltage	48 V AC, 60 V DC
Insulation resistance	>10 <sup>8</sup> Ω
Contact resistance	≤10 mΩ
Mating cycles	≥500
Wire outer diameter	≤2.3 mm
Locking type	Screw locking, PushPull
Degree of protection acc. to IEC 60529	IP65 / IP67, when mated
Conductor cross-section	0.13 ... 0.82 mm <sup>2</sup> , 0.09 ... 0.25 mm <sup>2</sup> , 0.13 ... 0.33 mm <sup>2</sup> , 0.25 ... 0.52 mm <sup>2</sup> , 0.33 ... 0.82 mm <sup>2</sup>
Conductor cross-section	AWG 26 ... AWG 18, AWG 28 ... AWG 24, AWG 26 ... AWG 22, AWG 24 ... AWG 20, AWG 22 ... AWG 18
Cable diameter	5.7 ... 8.8 mm

## Technical characteristics

Transmission characteristics	Cat. 5, Class D up to 100 MHz
Tightening torque	0.6 Nm, 2 Nm Lock nut
Material (insert)	Liquid crystal polymer (LCP)
Material (hood/housing)	Zinc die-cast
Material (contacts)	Copper alloy
RoHS	compliant, compliant with exemption

## Specifications and approvals





IEC 61076-2-101  
UL 2238 CYJV2.E302521  
CSA-C22.2 No. 182.3 CYJV8.E302521



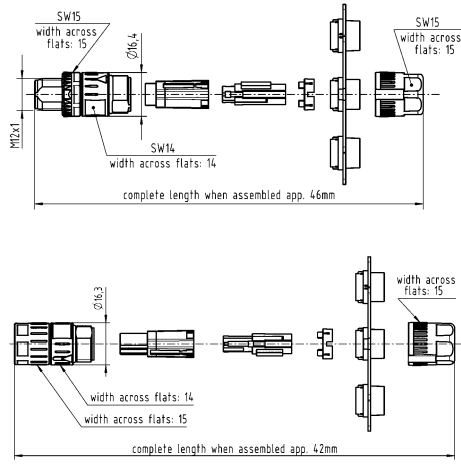

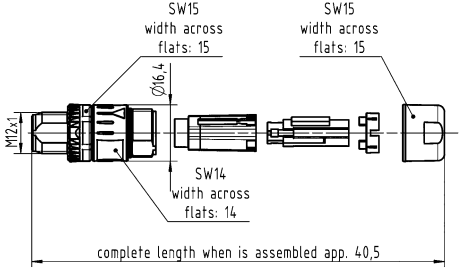

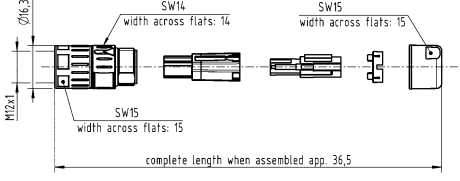
## Details

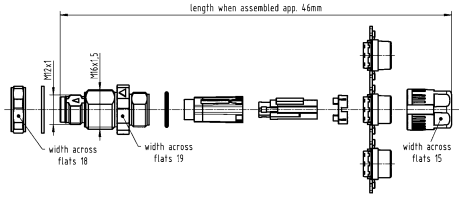
For Fast Ethernet applications only

Identification	Conductor cross-section (mm <sup>2</sup> )	Part number		Drawing (dimensions in mm)
		Male	Female	
Circular connectors M12, Slim Design, Cable connector, Straight, Crimp termination, Shielded    Please order crimp contacts separately.	0.13 ... 0.82	21 03 881 1405	21 03 881 2405	

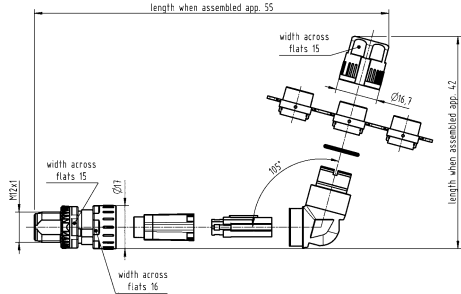
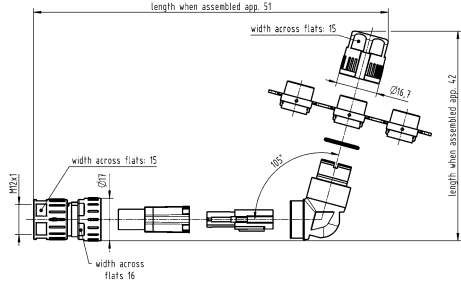
Identification	Conductor cross-section (mm <sup>2</sup> )	Part number		Drawing (dimensions in mm)
		Male	Female	
<p>Circular connectors M12, Slim Design, Cable connector, Straight, Crimp termination, Shielded, Shield connection with crimp flange</p>  <p>Please order crimp contacts separately. Please order crimp flange set separately.</p>	0.13 ... 0.82	21 03 881 1407	21 03 881 2407	
<p>Circular connectors M12, Slim Design, Cable connector, Panel feed through, for rear mounting, Crimp termination, Shielded</p>  <p>Please order crimp contacts separately.</p>	0.13 ... 0.82	21 03 881 1426	21 03 881 2425	
<p>Circular connectors M12, Slim Design, Cable connector, Panel feed through, for rear mounting, Crimp termination, Shielded, Shield connection with crimp flange</p>  <p>Please order crimp contacts separately. Please order crimp flange set separately.</p>	0.13 ... 0.82		21 03 881 2427	

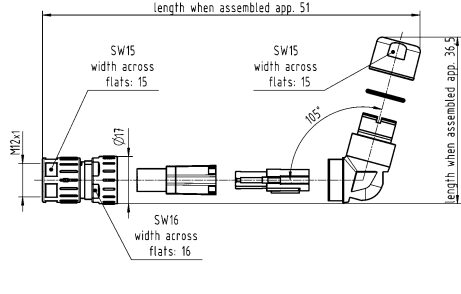
M12

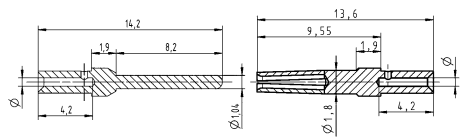
Identification	Conductor cross-section (mm <sup>2</sup> )	Part number		Drawing (dimensions in mm)															
		Male	Female																
<p>Circular connectors M12, Slim Design, Cable connector, Angled, Crimp termination, Shielded</p>  <p>Please order crimp contacts separately.</p>	0.13 ... 0.82	21 03 881 3405	21 03 881 4405	 															
<p>Circular connectors M12, Slim Design, Cable connector, Angled, Crimp termination, Shielded, Shield connection with crimp flange</p>  <p>Please order crimp contacts separately. Please order crimp flange set separately.</p>	0.13 ... 0.82	21 03 881 3407	21 03 881 4407																
<p>D-Sub, Standard, Crimp contact, Turned contacts</p> 	<p>0.09 ... 0.25</p> <p>0.13 ... 0.33</p> <p>0.25 ... 0.52</p> <p>0.33 ... 0.82</p>	<p>09 67 000 7576</p> <p>09 67 000 5576</p> <p>09 67 000 8576</p> <p>09 67 000 3576</p>	<p>09 67 000 7476</p> <p>09 67 000 5476</p> <p>09 67 000 8476</p> <p>09 67 000 3476</p>	 <table border="1"> <thead> <tr> <th>Wire gauge</th> <th>ø</th> <th>Stripping length</th> </tr> </thead> <tbody> <tr> <td>0.09-0.25 mm<sup>2</sup></td> <td>0.64 mm</td> <td>4 mm</td> </tr> <tr> <td>0.13-0.33 mm<sup>2</sup></td> <td>0.88 mm</td> <td>4 mm</td> </tr> <tr> <td>0.25-0.52 mm<sup>2</sup></td> <td>1.13 mm</td> <td>4 mm</td> </tr> <tr> <td>0.33-0.82 mm<sup>2</sup></td> <td>1.34 mm</td> <td>4 mm</td> </tr> </tbody> </table> <p>for stranded wire according IEC 60228 Class 5</p>	Wire gauge	ø	Stripping length	0.09-0.25 mm <sup>2</sup>	0.64 mm	4 mm	0.13-0.33 mm <sup>2</sup>	0.88 mm	4 mm	0.25-0.52 mm <sup>2</sup>	1.13 mm	4 mm	0.33-0.82 mm <sup>2</sup>	1.34 mm	4 mm
Wire gauge	ø	Stripping length																	
0.09-0.25 mm <sup>2</sup>	0.64 mm	4 mm																	
0.13-0.33 mm <sup>2</sup>	0.88 mm	4 mm																	
0.25-0.52 mm <sup>2</sup>	1.13 mm	4 mm																	
0.33-0.82 mm <sup>2</sup>	1.34 mm	4 mm																	

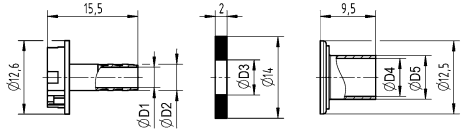
Identification	Conductor cross-section (mm <sup>2</sup> )	Part number		Drawing (dimensions in mm)																																																
		Male	Female																																																	
Circular connectors M12, Slim Design, Crimp flange set  <p>HARTING offers to test and define the best crimp flange and ferrule combination for customer specific cables.</p>		21 01 010 00xx	21 01 010 00xx	 <table border="1"> <thead> <tr> <th></th> <th>D1</th> <th>D2</th> <th>D3</th> <th>D4</th> <th>D5</th> </tr> </thead> <tbody> <tr> <td>21 01 010 0017</td> <td>3.5</td> <td>4.5</td> <td>6.0</td> <td>6.5</td> <td>7.5</td> </tr> <tr> <td>21 01 010 0018</td> <td>4.5</td> <td>5.5</td> <td>6.6</td> <td>7.5</td> <td>8.5</td> </tr> <tr> <td>21 01 010 0019</td> <td>4.5</td> <td>5.5</td> <td>6.8</td> <td>8.0</td> <td>9.0</td> </tr> <tr> <td>21 01 010 0020</td> <td>5.0</td> <td>6.0</td> <td>7.8</td> <td>9.0</td> <td>10.0</td> </tr> <tr> <td>21 01 010 0021</td> <td>6.5</td> <td>7.5</td> <td>8.0</td> <td>10.0</td> <td>10.8</td> </tr> <tr> <td>21 01 010 0022</td> <td>5.0</td> <td>6.0</td> <td>7.4</td> <td>9.0</td> <td>10.0</td> </tr> <tr> <td>21 01 010 0024</td> <td>5.5</td> <td>6.5</td> <td>8.8</td> <td>10.0</td> <td>10.8</td> </tr> </tbody> </table>		D1	D2	D3	D4	D5	21 01 010 0017	3.5	4.5	6.0	6.5	7.5	21 01 010 0018	4.5	5.5	6.6	7.5	8.5	21 01 010 0019	4.5	5.5	6.8	8.0	9.0	21 01 010 0020	5.0	6.0	7.8	9.0	10.0	21 01 010 0021	6.5	7.5	8.0	10.0	10.8	21 01 010 0022	5.0	6.0	7.4	9.0	10.0	21 01 010 0024	5.5	6.5	8.8	10.0	10.8
	D1	D2	D3	D4	D5																																															
21 01 010 0017	3.5	4.5	6.0	6.5	7.5																																															
21 01 010 0018	4.5	5.5	6.6	7.5	8.5																																															
21 01 010 0019	4.5	5.5	6.8	8.0	9.0																																															
21 01 010 0020	5.0	6.0	7.8	9.0	10.0																																															
21 01 010 0021	6.5	7.5	8.0	10.0	10.8																																															
21 01 010 0022	5.0	6.0	7.4	9.0	10.0																																															
21 01 010 0024	5.5	6.5	8.8	10.0	10.8																																															

M12

Number of contacts

# 8

Crimp termination  
Shielded

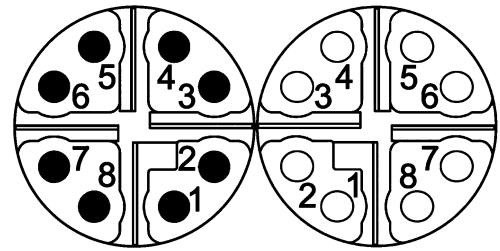

## Technical characteristics

Number of contacts	8
Rated current	0.5 A
Rated voltage	48 V
Rated impulse voltage	0.8 kV
Pollution degree	3
Insulation resistance	>10 <sup>8</sup> Ω
Contact resistance	≤10 mΩ
Mating cycles	≥500
Wire outer diameter	≤1.4 mm
Locking type	Screw locking, PushPull
Degree of protection acc. to IEC 60529	IP65 / IP67, when mated
Conductor cross-section	0.08 ... 0.25 mm <sup>2</sup> , 0.13 ... 0.25 mm <sup>2</sup> , 0.08 ... 0.22 mm <sup>2</sup>
Conductor cross-section	AWG 28 ... AWG 23, AWG 26 ... AWG 23, AWG 28 ... AWG 24
Cable diameter	5.7 ... 8.8 mm
Transmission characteristics	Cat. 6A, Class E <sub>A</sub> up to 500 MHz
Tightening torque	0.6 Nm, 2 Nm Lock nut

## Technical characteristics

Material (insert)	Liquid crystal polymer (LCP)
Material (hood/housing)	Zinc die-cast
Material (contacts)	Copper alloy
Surface (contacts)	Gold plated
RoHS	compliant, compliant with exemption

## Specifications and approvals





IEC 61076-2-109  
UL 2238 CYJV2.E302521  
CSA-C22.2 No. 182.3 CYJV8.E302521



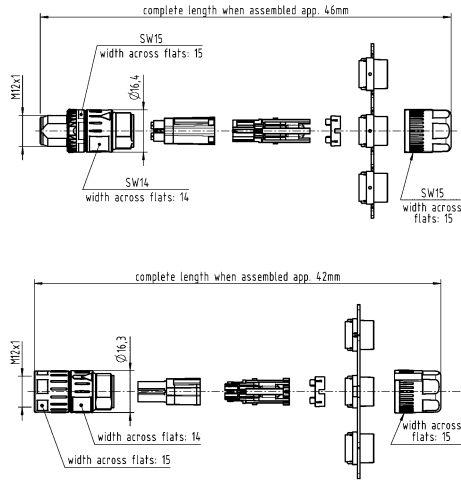

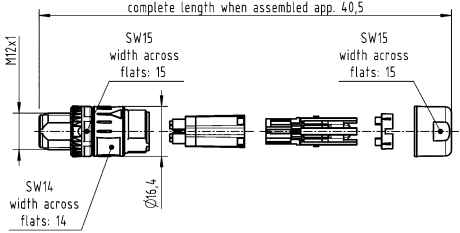
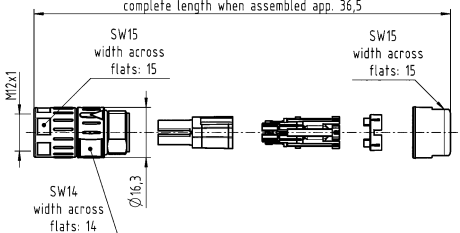

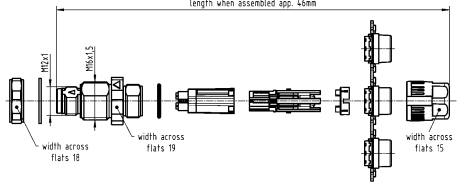
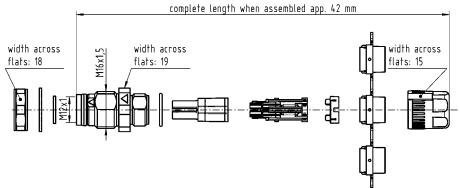
## Details

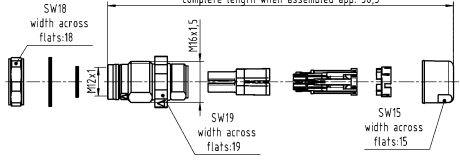
For Ethernet applications up to 10 Gbit only

Identification	Conductor cross-section (mm <sup>2</sup> )	Part number		Drawing (dimensions in mm)
		Male	Female	
Circular connectors M12, Slim Design, Cable connector, Straight, Crimp termination, Shielded    Please order crimp contacts separately.	0.08 ... 0.25	21 03 881 1805	21 03 881 2805	

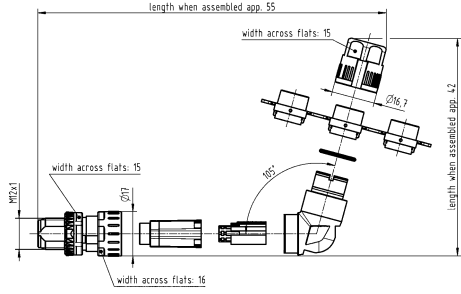
Identification	Conductor cross-section (mm <sup>2</sup> )	Part number		Drawing (dimensions in mm)
		Male	Female	
<p>Circular connectors M12, Slim Design, Cable connector, Straight, Crimp termination, Shielded, Shield connection with crimp flange</p>  <p>Please order crimp contacts separately. Please order crimp flange set separately.</p>	0.08 ... 0.25	21 03 881 1807	21 03 881 2807	 
<p>Circular connectors M12, Slim Design, Cable connector, Panel feed through, for rear mounting, Crimp termination, Shielded</p>  <p>Please order crimp contacts separately.</p>	0.08 ... 0.25	21 03 881 1825	21 03 881 2825	 
<p>Circular connectors M12, Slim Design, Cable connector, Panel feed through, for rear mounting, Crimp termination, Shielded, Shield connection with crimp flange</p>  <p>Please order crimp contacts separately. Please order crimp flange set separately.</p>	0.08 ... 0.25		21 03 881 2827	

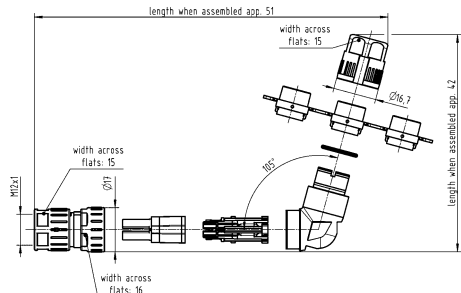
M12

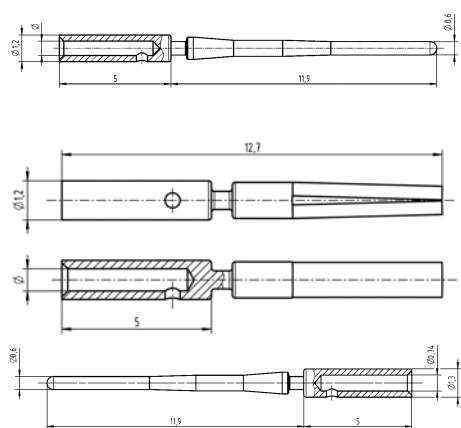
Identification	Conductor cross-section (mm <sup>2</sup> )	Part number		Drawing (dimensions in mm)
		Male	Female	
<p>Circular connectors M12, Slim Design, Cable connector, Angled, Crimp termination, Shielded</p>  <p>Please order crimp contacts separately.</p>	0.08 ... 0.25	21 03 881 3805	21 03 881 4805	
<p>Circular connectors M12, Slim Design, Cable connector, Angled, Crimp termination, Shielded, Shield connection with crimp flange</p>  <p>Please order crimp contacts separately. Please order crimp flange set separately.</p>	0.08 ... 0.25	21 03 881 3807	21 03 881 4807	
<p>har-speed, Crimp contact, Turned contacts</p> 	0.08 ... 0.22 0.13 ... 0.25	21 01 100 9014 21 01 100 9019	21 01 100 9023 21 01 100 9021	

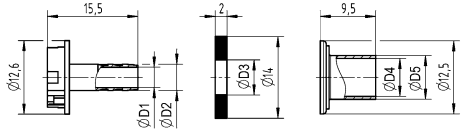
Identification	Conductor cross-section (mm <sup>2</sup> )	Part number		Drawing (dimensions in mm)																																																
		Male	Female																																																	
Circular connectors M12, Slim Design, Crimp flange set  <p>HARTING offers to test and define the best crimp flange and ferrule combination for customer specific cables.</p>		21 01 010 00xx	21 01 010 00xx	 <table border="1"> <thead> <tr> <th></th> <th>D1</th> <th>D2</th> <th>D3</th> <th>D4</th> <th>D5</th> </tr> </thead> <tbody> <tr> <td>21 01 010 0017</td> <td>3.5</td> <td>4.5</td> <td>6.0</td> <td>6.5</td> <td>7.5</td> </tr> <tr> <td>21 01 010 0018</td> <td>4.5</td> <td>5.5</td> <td>6.6</td> <td>7.5</td> <td>8.5</td> </tr> <tr> <td>21 01 010 0019</td> <td>4.5</td> <td>5.5</td> <td>6.8</td> <td>8.0</td> <td>9.0</td> </tr> <tr> <td>21 01 010 0020</td> <td>5.0</td> <td>6.0</td> <td>7.8</td> <td>9.0</td> <td>10.0</td> </tr> <tr> <td>21 01 010 0021</td> <td>6.5</td> <td>7.5</td> <td>8.0</td> <td>10.0</td> <td>10.8</td> </tr> <tr> <td>21 01 010 0022</td> <td>5.0</td> <td>6.0</td> <td>7.4</td> <td>9.0</td> <td>10.0</td> </tr> <tr> <td>21 01 010 0024</td> <td>5.5</td> <td>6.5</td> <td>8.8</td> <td>10.0</td> <td>10.8</td> </tr> </tbody> </table>		D1	D2	D3	D4	D5	21 01 010 0017	3.5	4.5	6.0	6.5	7.5	21 01 010 0018	4.5	5.5	6.6	7.5	8.5	21 01 010 0019	4.5	5.5	6.8	8.0	9.0	21 01 010 0020	5.0	6.0	7.8	9.0	10.0	21 01 010 0021	6.5	7.5	8.0	10.0	10.8	21 01 010 0022	5.0	6.0	7.4	9.0	10.0	21 01 010 0024	5.5	6.5	8.8	10.0	10.8
	D1	D2	D3	D4	D5																																															
21 01 010 0017	3.5	4.5	6.0	6.5	7.5																																															
21 01 010 0018	4.5	5.5	6.6	7.5	8.5																																															
21 01 010 0019	4.5	5.5	6.8	8.0	9.0																																															
21 01 010 0020	5.0	6.0	7.8	9.0	10.0																																															
21 01 010 0021	6.5	7.5	8.0	10.0	10.8																																															
21 01 010 0022	5.0	6.0	7.4	9.0	10.0																																															
21 01 010 0024	5.5	6.5	8.8	10.0	10.8																																															

M12

Number of contacts

# 8

4 Power + 4 Data  
Crimp termination  
Shielded

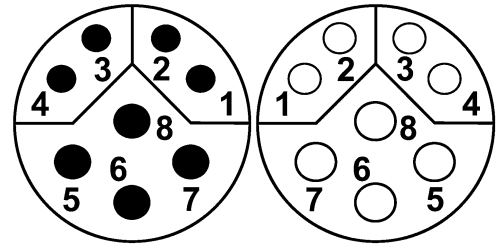

## Technical characteristics

Number of contacts	8
Rated current	6 A
Rated voltage	50 V
Rated impulse voltage	1.5 kV
Pollution degree	3
Rated current (data)	0.5 A
Insulation resistance	>10 <sup>8</sup> Ω
Contact resistance	≤10 mΩ
Mating cycles	≥100
Locking type	PushPull, Screw locking
Degree of protection acc. to IEC 60529	IP65 / IP67, when mated
Conductor cross-section	0.33 ... 0.82 mm <sup>2</sup> , 0.13 ... 0.25 mm <sup>2</sup> , 0.08 ... 0.22 mm <sup>2</sup>
Conductor cross-section	AWG 22 ... AWG 18, AWG 26 ... AWG 23, AWG 28 ... AWG 24

## Technical characteristics

Cable diameter	5.7 ... 8.8 mm
Tightening torque	0.6 Nm
Material (insert)	Polyamide (PA)
Material (hood/housing)	Zinc die-cast
Material (contacts)	Copper alloy
Surface (contacts)	Gold plated
RoHS	compliant with exemption

## Specifications and approvals

IEC 61076-2-113

## Details

For Fast Ethernet applications only

Identification	Conductor cross-section (mm <sup>2</sup> )	Part number		Drawing (dimensions in mm)
		Male	Female	
Circular connectors M12, Slim Design, Cable connector, Straight, Crimp termination, Shielded, PushPull locking Please order crimp contacts separately.		21 03 861 1830		
Circular connectors M12, Slim Design, Cable connector, Straight, Crimp termination, Shielded, Screw locking Please order crimp contacts separately.		21 03 861 1814	21 03 861 2805	

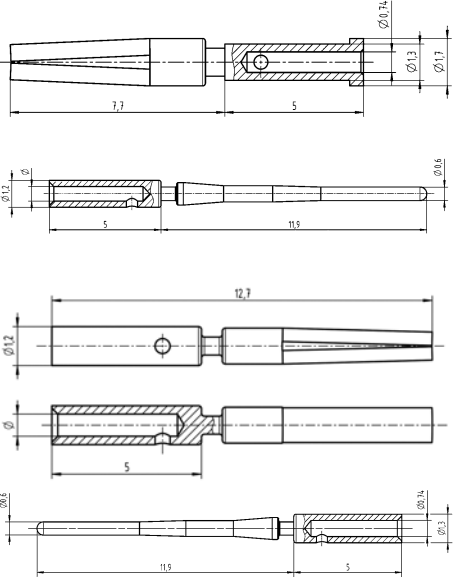
Identification	Conductor cross-section (mm <sup>2</sup> )	Part number		Drawing (dimensions in mm)
		Male	Female	
Circular connectors M12, Slim Design, Cable connector, Panel feed through, for rear mounting, Crimp termination, Shielded Please order crimp contacts separately.		21 03 861 1825	21 03 861 2825	
Circular connectors M12, Power, Crimp contact, Turned contacts, Pack contents: 50 pieces  <i>har-speed</i> , Crimp contact, Turned contacts  	0.13 ... 0.25 0.33 ... 0.82  0.08 ... 0.22 0.13 ... 0.25	21 01 100 9982 21 01 100 9981  21 01 100 9014 21 01 100 9019	21 01 100 9984 21 01 100 9983  21 01 100 9023 21 01 100 9021	

M12

Number of contacts

# 4

HARAX® connection technology  
Shielded

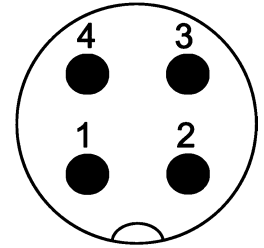

## Technical characteristics

Number of contacts	4
Rated current	4 A
Rated voltage	50 V
Rated impulse voltage	1.5 kV
Pollution degree	3
Insulation resistance	>10 <sup>8</sup> Ω
Contact resistance	≤10 mΩ
Mating cycles	≥500
Wire outer diameter	≤1.6 mm
Locking type	PushPull
Degree of protection acc. to IEC 60529	IP65 / IP67, when mated
Conductor cross-section	0.34 mm <sup>2</sup> , 0.14 mm <sup>2</sup>
Conductor cross-section	AWG 22, AWG 26

## Technical characteristics

Cable diameter	5.7 ... 8.8 mm
Material (insert)	Polyamide (PA)
Material (hood/housing)	Zinc die-cast
Material (contacts)	Copper alloy
Surface (contacts)	Gold plated
RoHS	compliant with exemption

## Specifications and approvals

IEC 61076-2-101  
UL 2238 CYJV2.E302521  
CSA-C22.2 No. 182.3 CYJV8.E302521

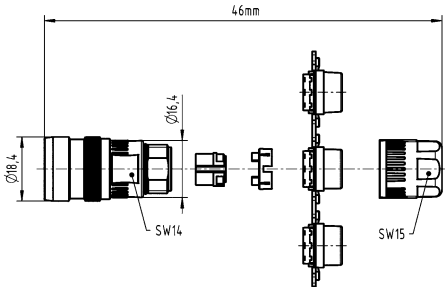
Identification	Conductor cross-section (mm <sup>2</sup> )	Part number Male	Drawing (dimensions in mm)
Circular connectors M12, PushPull, Cable connector, Straight, HARAX® connection technology, Shielded 	0.14 0.34	21 03 322 1411 21 03 322 1401	

Number of contacts

# 5

Crimp termination  
Shielded

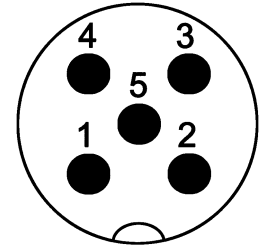

M12

## Technical characteristics



Number of contacts	5
Rated current	4 A
Rated impulse voltage	1.5 kV
Pollution degree	3
Rated voltage	48 V AC, 60 V DC
Insulation resistance	>10 <sup>8</sup> Ω
Contact resistance	≤10 mΩ
Mating cycles	≥500
Wire outer diameter	≤2.3 mm
Locking type	PushPull
Degree of protection acc. to IEC 60529	IP65 / IP67, when mated
Conductor cross-section	0.13 ... 0.82 mm <sup>2</sup> , 0.09 ... 0.25 mm <sup>2</sup> , 0.13 ... 0.33 mm <sup>2</sup> , 0.25 ... 0.52 mm <sup>2</sup> , 0.33 ... 0.82 mm <sup>2</sup>

## Technical characteristics



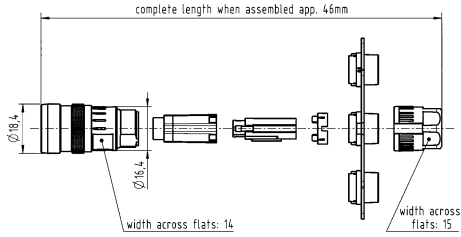

Conductor cross-section	AWG 26 ... AWG 18, AWG 28 ... AWG 24, AWG 26 ... AWG 22, AWG 24 ... AWG 20, AWG 22 ... AWG 18
Cable diameter	5.7 ... 8.8 mm
Material (insert)	Liquid crystal polymer (LCP)
Material (hood/housing)	Zinc die-cast
Material (contacts)	Copper alloy
RoHS	compliant with exemption

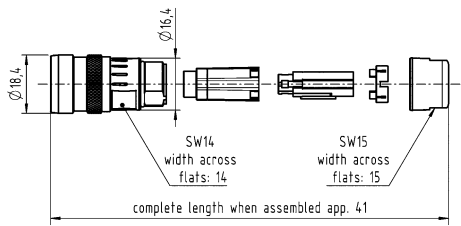
## Specifications and approvals

IEC 61076-2-101  
UL 2238 CYJV2.E302521  
CSA-C22.2 No. 182.3 CYJV8.E302521

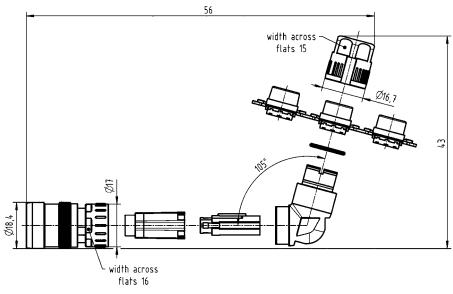
Identification	Conductor cross-section (mm <sup>2</sup> )	Part number		Drawing (dimensions in mm)
		Male	Female	
Circular connectors M12, PushPull, Cable connector, Straight, Crimp termination, Shielded 	0.13 ... 0.82	21 03 821 1530		
Please order crimp contacts separately.  Circular connectors M12, PushPull, Cable connector, Straight, Crimp termination, Shielded, Shield connection with crimp flange 	0.13 ... 0.82	21 03 821 1533		
Please order crimp contacts separately. Please order crimp flange set separately.				

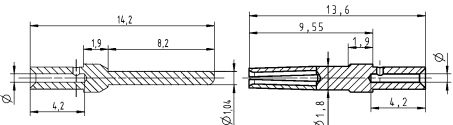
M12

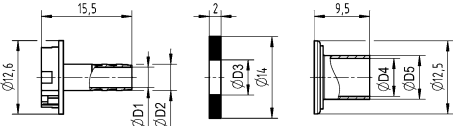
Identification	Conductor cross-section (mm <sup>2</sup> )	Part number		Drawing (dimensions in mm)																																																
		Male	Female																																																	
<p>Circular connectors M12, PushPull, Cable connector, Angled, Crimp termination, Shielded</p>  <p>Please order crimp contacts separately.</p>	0.13 ... 0.82	21 03 821 3530																																																		
<p>Circular connectors M12, PushPull, Cable connector, Angled, Crimp termination, Shielded, Shield connection with crimp flange</p>  <p>Please order crimp contacts separately. Please order crimp flange set separately.</p>	0.13 ... 0.82	21 03 821 3533																																																		
<p>D-Sub, Standard, Crimp contact, Turned contacts</p> 	<p>0.09 ... 0.25 0.13 ... 0.33 0.25 ... 0.52 0.33 ... 0.82</p>	<p>09 67 000 7576 09 67 000 5576 09 67 000 8576 09 67 000 3576</p>	<p>09 67 000 7476 09 67 000 5476 09 67 000 8476 09 67 000 3476</p>	 <table border="1"> <thead> <tr> <th>Wire gauge</th> <th>Ø</th> <th>Stripping length</th> </tr> </thead> <tbody> <tr> <td>0.09-0.25 mm<sup>2</sup></td> <td>0.64 mm</td> <td>4 mm</td> </tr> <tr> <td>0.13-0.33 mm<sup>2</sup></td> <td>0.88 mm</td> <td>4 mm</td> </tr> <tr> <td>0.25-0.52 mm<sup>2</sup></td> <td>1.13 mm</td> <td>4 mm</td> </tr> <tr> <td>0.33-0.82 mm<sup>2</sup></td> <td>1.34 mm</td> <td>4 mm</td> </tr> </tbody> </table> <p>for stranded wire according IEC 60228 Class 5</p>	Wire gauge	Ø	Stripping length	0.09-0.25 mm <sup>2</sup>	0.64 mm	4 mm	0.13-0.33 mm <sup>2</sup>	0.88 mm	4 mm	0.25-0.52 mm <sup>2</sup>	1.13 mm	4 mm	0.33-0.82 mm <sup>2</sup>	1.34 mm	4 mm																																	
Wire gauge	Ø	Stripping length																																																		
0.09-0.25 mm <sup>2</sup>	0.64 mm	4 mm																																																		
0.13-0.33 mm <sup>2</sup>	0.88 mm	4 mm																																																		
0.25-0.52 mm <sup>2</sup>	1.13 mm	4 mm																																																		
0.33-0.82 mm <sup>2</sup>	1.34 mm	4 mm																																																		
<p>Circular connectors M12, Slim Design, Crimp flange set</p>  <p>HARTING offers to test and define the best crimp flange and ferrule combination for customer specific cables.</p>		21 01 010 00xx	21 01 010 00xx	 <table border="1"> <thead> <tr> <th></th> <th>D1</th> <th>D2</th> <th>D3</th> <th>D4</th> <th>D5</th> </tr> </thead> <tbody> <tr> <td>21 01 010 0017</td> <td>3.5</td> <td>4.5</td> <td>6.0</td> <td>6.5</td> <td>7.5</td> </tr> <tr> <td>21 01 010 0018</td> <td>4.5</td> <td>5.5</td> <td>6.6</td> <td>7.5</td> <td>8.5</td> </tr> <tr> <td>21 01 010 0019</td> <td>4.5</td> <td>5.5</td> <td>6.8</td> <td>8.0</td> <td>9.0</td> </tr> <tr> <td>21 01 010 0020</td> <td>5.0</td> <td>6.0</td> <td>7.8</td> <td>9.0</td> <td>10.0</td> </tr> <tr> <td>21 01 010 0021</td> <td>6.5</td> <td>7.5</td> <td>8.0</td> <td>10.0</td> <td>10.8</td> </tr> <tr> <td>21 01 010 0022</td> <td>5.0</td> <td>6.0</td> <td>7.4</td> <td>9.0</td> <td>10.0</td> </tr> <tr> <td>21 01 010 0024</td> <td>5.5</td> <td>6.5</td> <td>8.8</td> <td>10.0</td> <td>10.8</td> </tr> </tbody> </table>		D1	D2	D3	D4	D5	21 01 010 0017	3.5	4.5	6.0	6.5	7.5	21 01 010 0018	4.5	5.5	6.6	7.5	8.5	21 01 010 0019	4.5	5.5	6.8	8.0	9.0	21 01 010 0020	5.0	6.0	7.8	9.0	10.0	21 01 010 0021	6.5	7.5	8.0	10.0	10.8	21 01 010 0022	5.0	6.0	7.4	9.0	10.0	21 01 010 0024	5.5	6.5	8.8	10.0	10.8
	D1	D2	D3	D4	D5																																															
21 01 010 0017	3.5	4.5	6.0	6.5	7.5																																															
21 01 010 0018	4.5	5.5	6.6	7.5	8.5																																															
21 01 010 0019	4.5	5.5	6.8	8.0	9.0																																															
21 01 010 0020	5.0	6.0	7.8	9.0	10.0																																															
21 01 010 0021	6.5	7.5	8.0	10.0	10.8																																															
21 01 010 0022	5.0	6.0	7.4	9.0	10.0																																															
21 01 010 0024	5.5	6.5	8.8	10.0	10.8																																															

Number of contacts

# 8

Crimp termination  
Shielded

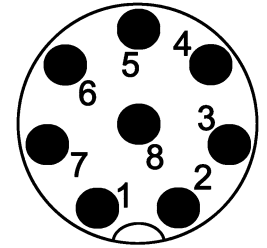

M12

## Technical characteristics



Number of contacts	8
Rated current	2 A
Rated impulse voltage	0.8 kV
Pollution degree	3
Rated voltage	30 V AC, 30 V DC
Insulation resistance	>10 <sup>8</sup> Ω
Contact resistance	≤10 mΩ
Mating cycles	≥500
Wire outer diameter	≤1.65 mm
Locking type	PushPull
Degree of protection acc. to IEC 60529	IP65 / IP67, when mated
Conductor cross-section	0.13 ... 0.33 mm <sup>2</sup>
Conductor cross-section	AWG 26 ... AWG 22

## Technical characteristics



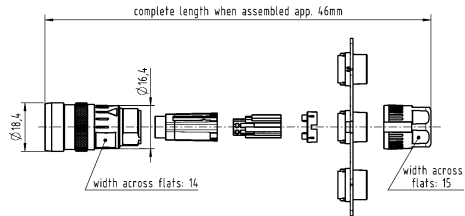

Cable diameter	5.7 ... 8.8 mm
Material (insert)	Liquid crystal polymer (LCP)
Material (hood/housing)	Zinc die-cast
Material (contacts)	Copper alloy
Surface (contacts)	Gold plated
RoHS	compliant with exemption

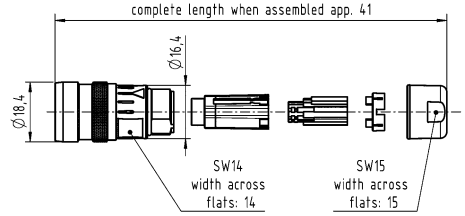
## Specifications and approvals

IEC 61076-2-101  
UL 2238 CYJV2.E302521  
CSA-C22.2 No. 182.3 CYJV8.E302521

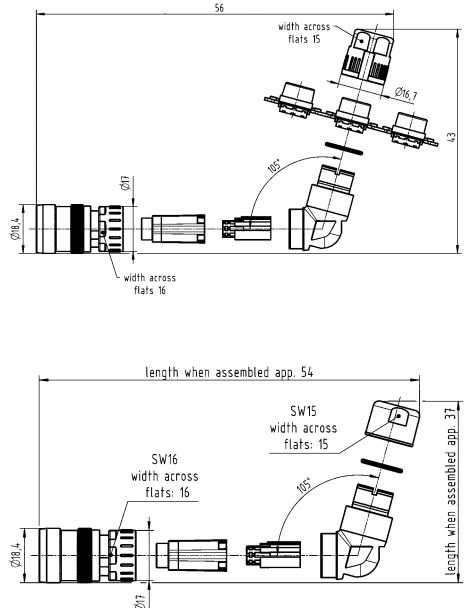
Identification	Conductor cross-section (mm <sup>2</sup> )	Part number		Drawing (dimensions in mm)
		Male	Female	
<p>Circular connectors M12, PushPull, Cable connector, Straight, Crimp termination, Shielded</p>  <p>Please order crimp contacts separately.</p>	0.13 ... 0.33	21 03 821 1830		
<p>Circular connectors M12, PushPull, Cable connector, Straight, Crimp termination, Shielded, Shield connection with crimp flange</p>  <p>Please order crimp contacts separately. Please order crimp flange set separately.</p>	0.13 ... 0.33	21 03 821 1833		

M12

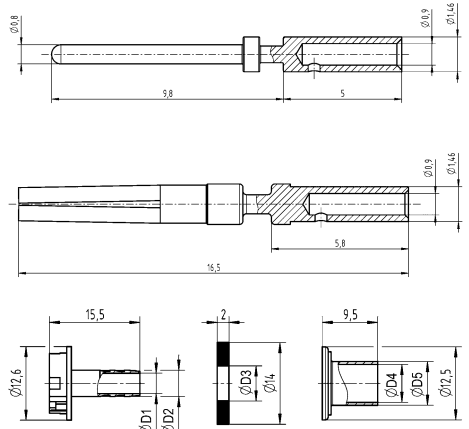
Identification	Conductor cross-section (mm <sup>2</sup> )	Part number		Drawing (dimensions in mm)																																																
		Male	Female																																																	
<p>Circular connectors M12, PushPull, Cable connector, Angled, Crimp termination, Shielded</p>  <p>Please order crimp contacts separately.</p>	0.13 ... 0.33	21 03 821 3830																																																		
<p>Circular connectors M12, PushPull, Cable connector, Angled, Crimp termination, Shielded, Shield connection with crimp flange</p>  <p>Please order crimp contacts separately. Please order crimp flange set separately.</p>	0.13 ... 0.33	21 03 821 3833																																																		
<p>Circular connectors M12, Crimp contact, Turned contacts</p>  <p>Circular connectors M12, Slim Design, Crimp flange set</p>  <p>HARTING offers to test and define the best crimp flange and ferrule combination for customer specific cables.</p>	0.13 ... 0.33	21 01 100 9020	21 01 100 9025	 <table border="1" data-bbox="965 1534 1412 1758"> <thead> <tr> <th></th> <th>D1</th> <th>D2</th> <th>D3</th> <th>D4</th> <th>D5</th> </tr> </thead> <tbody> <tr> <td>21 01 010 0017</td> <td>3.5</td> <td>4.5</td> <td>6.0</td> <td>6.5</td> <td>7.5</td> </tr> <tr> <td>21 01 010 0018</td> <td>4.5</td> <td>5.5</td> <td>6.6</td> <td>7.5</td> <td>8.5</td> </tr> <tr> <td>21 01 010 0019</td> <td>4.5</td> <td>5.5</td> <td>6.8</td> <td>8.0</td> <td>9.0</td> </tr> <tr> <td>21 01 010 0020</td> <td>5.0</td> <td>6.0</td> <td>7.8</td> <td>9.0</td> <td>10.0</td> </tr> <tr> <td>21 01 010 0021</td> <td>6.5</td> <td>7.5</td> <td>8.0</td> <td>10.0</td> <td>10.8</td> </tr> <tr> <td>21 01 010 0022</td> <td>5.0</td> <td>6.0</td> <td>7.4</td> <td>9.0</td> <td>10.0</td> </tr> <tr> <td>21 01 010 0024</td> <td>5.5</td> <td>6.5</td> <td>8.8</td> <td>10.0</td> <td>10.8</td> </tr> </tbody> </table>		D1	D2	D3	D4	D5	21 01 010 0017	3.5	4.5	6.0	6.5	7.5	21 01 010 0018	4.5	5.5	6.6	7.5	8.5	21 01 010 0019	4.5	5.5	6.8	8.0	9.0	21 01 010 0020	5.0	6.0	7.8	9.0	10.0	21 01 010 0021	6.5	7.5	8.0	10.0	10.8	21 01 010 0022	5.0	6.0	7.4	9.0	10.0	21 01 010 0024	5.5	6.5	8.8	10.0	10.8
	D1	D2	D3	D4	D5																																															
21 01 010 0017	3.5	4.5	6.0	6.5	7.5																																															
21 01 010 0018	4.5	5.5	6.6	7.5	8.5																																															
21 01 010 0019	4.5	5.5	6.8	8.0	9.0																																															
21 01 010 0020	5.0	6.0	7.8	9.0	10.0																																															
21 01 010 0021	6.5	7.5	8.0	10.0	10.8																																															
21 01 010 0022	5.0	6.0	7.4	9.0	10.0																																															
21 01 010 0024	5.5	6.5	8.8	10.0	10.8																																															

Number of contacts

# 4

HARAX® connection technology  
Shielded

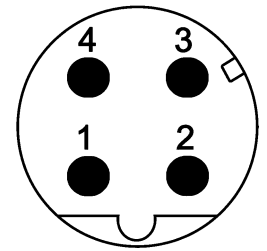

M12

## Technical characteristics

Number of contacts	4
Rated current	4 A
Rated voltage	50 V
Rated impulse voltage	1.5 kV
Pollution degree	3
Insulation resistance	>10 <sup>8</sup> Ω
Contact resistance	≤10 mΩ
Mating cycles	≥500
Wire outer diameter	≤1.6 mm
Locking type	PushPull
Degree of protection acc. to IEC 60529	IP65 / IP67, when mated
Conductor cross-section	0.34 mm <sup>2</sup> , 0.14 mm <sup>2</sup>
Conductor cross-section	AWG 22, AWG 26
Cable diameter	5.7 ... 8.8 mm
Transmission characteristics	Cat. 5, Class D up to 100 MHz
Material (insert)	Polyamide (PA)
Material (hood/housing)	Zinc die-cast

## Technical characteristics

Material (contacts)	Copper alloy
Surface (contacts)	Gold plated
RoHS	compliant with exemption

## Specifications and approvals

IEC 61076-2-101  
UL 2238 CYJV2.E302521  
CSA-C22.2 No. 182.3 CYJV8.E302521



## Details

For Fast Ethernet applications only

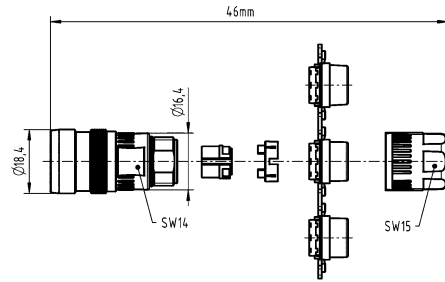
Identification	Conductor cross-section (mm <sup>2</sup> )	Part number Male	Drawing (dimensions in mm)
Circular connectors M12, PushPull, Cable connector, Straight, HARAX® connection technology, Shielded  	0.14 0.34	21 03 382 1411 21 03 382 1401	

Number of contacts

# 4

Crimp termination  
Shielded

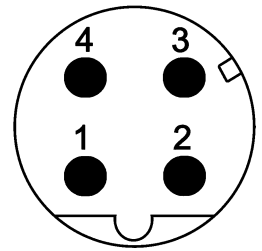

## Technical characteristics

Number of contacts	4
Rated current	4 A
Rated impulse voltage	1.5 kV
Pollution degree	3
Rated voltage	48 V AC, 60 V DC
Insulation resistance	>10 <sup>8</sup> Ω
Contact resistance	≤10 mΩ
Mating cycles	≥500
Wire outer diameter	≤2.3 mm
Locking type	PushPull
Degree of protection acc. to IEC 60529	IP65 / IP67, when mated
Conductor cross-section	0.13 ... 0.82 mm <sup>2</sup> , 0.09 ... 0.25 mm <sup>2</sup> , 0.13 ... 0.33 mm <sup>2</sup> , 0.25 ... 0.52 mm <sup>2</sup> , 0.33 ... 0.82 mm <sup>2</sup>
Conductor cross-section	AWG 26 ... AWG 18, AWG 28 ... AWG 24, AWG 26 ... AWG 22, AWG 24 ... AWG 20, AWG 22 ... AWG 18

## Technical characteristics

Cable diameter	5.7 ... 8.8 mm
Transmission characteristics	Cat. 5, Class D up to 100 MHz
Material (insert)	Liquid crystal polymer (LCP)
Material (hood/housing)	Zinc die-cast
Material (contacts)	Copper alloy
RoHS	compliant with exemption



## Specifications and approvals





IEC 61076-2-101  
UL 2238 CYJV2.E302521  
CSA-C22.2 No. 182.3 CYJV8.E302521

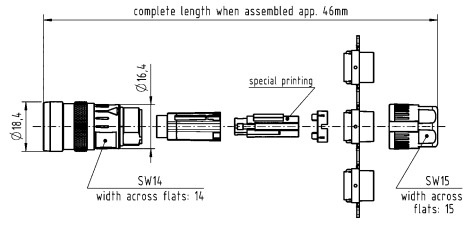

## Details

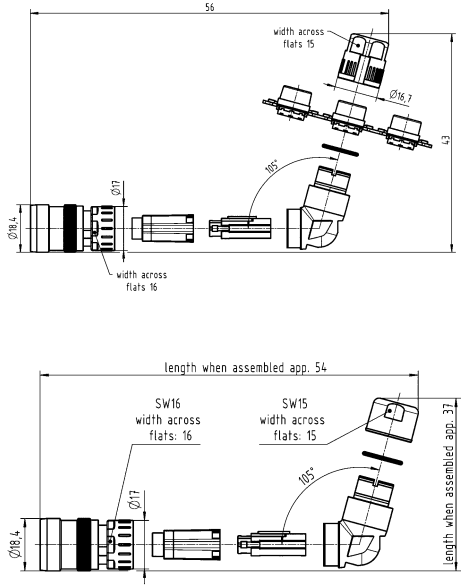
For Fast Ethernet applications only

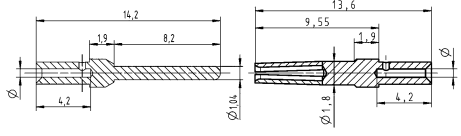
Identification	Conductor cross-section (mm <sup>2</sup> )	Part number		Drawing (dimensions in mm)
		Male	Female	
Circular connectors M12, PushPull, Cable connector, Straight, Crimp termination, Shielded  <p>Please order crimp contacts separately.</p>	0.13 ... 0.82	21 03 881 1430		
Circular connectors M12, PushPull, Cable connector, Straight, Crimp termination, Shielded, Shield connection with crimp flange  <p>Please order crimp contacts separately. Please order crimp flange set separately.</p>	0.13 ... 0.82	21 03 881 1433		

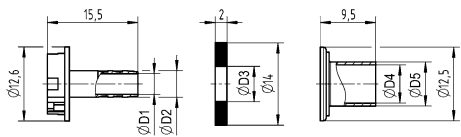
Identification	Conductor cross-section (mm <sup>2</sup> )	Part number		Drawing (dimensions in mm)																																																
		Male	Female																																																	
Circular connectors M12, PushPull, Cable connector, Angled, Crimp termination, Shielded  Please order crimp contacts separately.	0.13 ... 0.82	21 03 881 3430																																																		
Circular connectors M12, PushPull, Cable connector, Angled, Crimp termination, Shielded, Shield connection with crimp flange  Please order crimp contacts separately. Please order crimp flange set separately.	0.13 ... 0.82	21 03 881 3433																																																		
D-Sub, Standard, Crimp contact, Turned contacts 	0.09 ... 0.25 0.13 ... 0.33 0.25 ... 0.52 0.33 ... 0.82	09 67 000 7576 09 67 000 5576 09 67 000 8576 09 67 000 3576	09 67 000 7476 09 67 000 5476 09 67 000 8476 09 67 000 3476	 <table border="1"> <thead> <tr> <th>Wire gauge</th> <th>Ø</th> <th>Stripping length</th> </tr> </thead> <tbody> <tr> <td>0.09-0.25 mm<sup>2</sup></td> <td>0.64 mm</td> <td>4 mm</td> </tr> <tr> <td>0.13-0.33 mm<sup>2</sup></td> <td>0.88 mm</td> <td>4 mm</td> </tr> <tr> <td>0.25-0.52 mm<sup>2</sup></td> <td>1.13 mm</td> <td>4 mm</td> </tr> <tr> <td>0.33-0.82 mm<sup>2</sup></td> <td>1.34 mm</td> <td>4 mm</td> </tr> </tbody> </table> for stranded wire according IEC 60228 Class 5	Wire gauge	Ø	Stripping length	0.09-0.25 mm <sup>2</sup>	0.64 mm	4 mm	0.13-0.33 mm <sup>2</sup>	0.88 mm	4 mm	0.25-0.52 mm <sup>2</sup>	1.13 mm	4 mm	0.33-0.82 mm <sup>2</sup>	1.34 mm	4 mm																																	
Wire gauge	Ø	Stripping length																																																		
0.09-0.25 mm <sup>2</sup>	0.64 mm	4 mm																																																		
0.13-0.33 mm <sup>2</sup>	0.88 mm	4 mm																																																		
0.25-0.52 mm <sup>2</sup>	1.13 mm	4 mm																																																		
0.33-0.82 mm <sup>2</sup>	1.34 mm	4 mm																																																		
Circular connectors M12, Slim Design, Crimp flange set  HARTING offers to test and define the best crimp flange and ferrule combination for customer specific cables.		21 01 010 00xx	21 01 010 00xx	 <table border="1"> <thead> <tr> <th></th> <th>D1</th> <th>D2</th> <th>D3</th> <th>D4</th> <th>D5</th> </tr> </thead> <tbody> <tr> <td>21 01 010 0017</td> <td>3.5</td> <td>4.5</td> <td>6.0</td> <td>6.5</td> <td>7.5</td> </tr> <tr> <td>21 01 010 0018</td> <td>4.5</td> <td>5.5</td> <td>6.6</td> <td>7.5</td> <td>8.5</td> </tr> <tr> <td>21 01 010 0019</td> <td>4.5</td> <td>5.5</td> <td>6.8</td> <td>8.0</td> <td>9.0</td> </tr> <tr> <td>21 01 010 0020</td> <td>5.0</td> <td>6.0</td> <td>7.8</td> <td>9.0</td> <td>10.0</td> </tr> <tr> <td>21 01 010 0021</td> <td>6.5</td> <td>7.5</td> <td>8.0</td> <td>10.0</td> <td>10.8</td> </tr> <tr> <td>21 01 010 0022</td> <td>5.0</td> <td>6.0</td> <td>7.4</td> <td>9.0</td> <td>10.0</td> </tr> <tr> <td>21 01 010 0024</td> <td>5.5</td> <td>6.5</td> <td>8.8</td> <td>10.0</td> <td>10.8</td> </tr> </tbody> </table>		D1	D2	D3	D4	D5	21 01 010 0017	3.5	4.5	6.0	6.5	7.5	21 01 010 0018	4.5	5.5	6.6	7.5	8.5	21 01 010 0019	4.5	5.5	6.8	8.0	9.0	21 01 010 0020	5.0	6.0	7.8	9.0	10.0	21 01 010 0021	6.5	7.5	8.0	10.0	10.8	21 01 010 0022	5.0	6.0	7.4	9.0	10.0	21 01 010 0024	5.5	6.5	8.8	10.0	10.8
	D1	D2	D3	D4	D5																																															
21 01 010 0017	3.5	4.5	6.0	6.5	7.5																																															
21 01 010 0018	4.5	5.5	6.6	7.5	8.5																																															
21 01 010 0019	4.5	5.5	6.8	8.0	9.0																																															
21 01 010 0020	5.0	6.0	7.8	9.0	10.0																																															
21 01 010 0021	6.5	7.5	8.0	10.0	10.8																																															
21 01 010 0022	5.0	6.0	7.4	9.0	10.0																																															
21 01 010 0024	5.5	6.5	8.8	10.0	10.8																																															

Number of contacts

# 8

Crimp termination  
Shielded

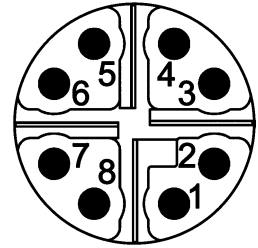

## Technical characteristics

Number of contacts	8
Rated current	0.5 A
Rated voltage	48 V
Rated impulse voltage	0.8 kV
Pollution degree	3
Insulation resistance	>10 <sup>8</sup> Ω
Contact resistance	≤10 mΩ
Mating cycles	≥500
Wire outer diameter	≤1.4 mm
Locking type	PushPull
Degree of protection acc. to IEC 60529	IP65 / IP67, when mated
Conductor cross-section	0.08 ... 0.25 mm <sup>2</sup> , 0.13 ... 0.25 mm <sup>2</sup> , 0.08 ... 0.22 mm <sup>2</sup>
Conductor cross-section	AWG 28 ... AWG 23, AWG 26 ... AWG 23, AWG 28 ... AWG 24
Cable diameter	5.7 ... 8.8 mm
Transmission characteristics	Cat. 6A, Class E <sub>A</sub> up to 500 MHz

## Technical characteristics

Material (insert)	Liquid crystal polymer (LCP)
Material (hood/housing)	Zinc die-cast
Material (contacts)	Copper alloy
Surface (contacts)	Gold plated
RoHS	compliant with exemption



## Specifications and approvals





IEC 61076-2-109  
UL 2238 CYJV2.E302521  
CSA-C22.2 No. 182.3 CYJV8.E302521

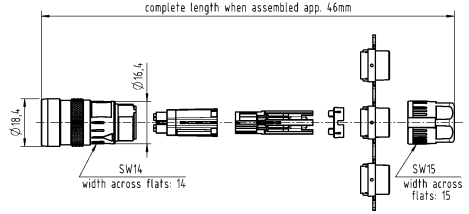

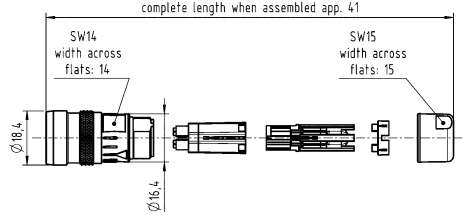
## Details

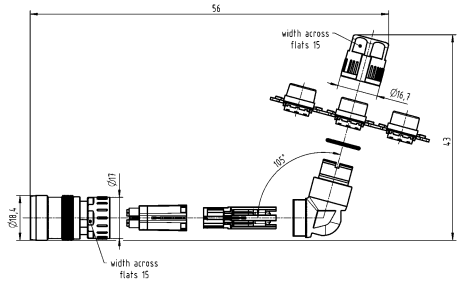
For Ethernet applications up to 10 Gbit only

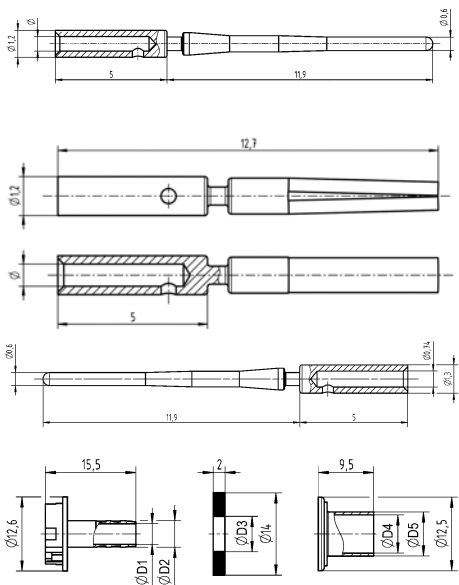
Identification	Conductor cross-section (mm <sup>2</sup> )	Part number		Drawing (dimensions in mm)
		Male	Female	
Circular connectors M12, PushPull, Cable connector, Straight, Crimp termination, Shielded  <p>Please order crimp contacts separately.</p>	0.08 ... 0.25	21 03 881 1830		
Circular connectors M12, PushPull, Cable connector, Straight, Crimp termination, Shielded, Shield connection with crimp flange  <p>Please order crimp contacts separately. Please order crimp flange set separately.</p>	0.08 ... 0.25	21 03 881 1833		

Identification	Conductor cross-section (mm <sup>2</sup> )	Part number		Drawing (dimensions in mm)																																																
		Male	Female																																																	
<p>Circular connectors M12, PushPull, Cable connector, Angled, Crimp termination, Shielded</p>  <p>Please order crimp contacts separately.</p>	0.08 ... 0.25	21 03 881 3830																																																		
<p>Circular connectors M12, PushPull, Cable connector, Angled, Crimp termination, Shielded, Shield connection with crimp flange</p>  <p>Please order crimp contacts separately. Please order crimp flange set separately.</p>	0.08 ... 0.25	21 03 881 3833																																																		
<p>har-speed, Crimp contact, Turned contacts</p> 	0.08 ... 0.22 0.13 ... 0.25	21 01 100 9014 21 01 100 9019	21 01 100 9023 21 01 100 9021																																																	
<p>Circular connectors M12, Slim Design, Crimp flange set</p>  <p>HARTING offers to test and define the best crimp flange and ferrule combination for customer specific cables.</p>		21 01 010 00xx	21 01 010 00xx	<table border="1"> <thead> <tr> <th></th> <th>D1</th> <th>D2</th> <th>D3</th> <th>D4</th> <th>D5</th> </tr> </thead> <tbody> <tr> <td>21 01 010 0017</td> <td>3.5</td> <td>4.5</td> <td>6.0</td> <td>6.5</td> <td>7.5</td> </tr> <tr> <td>21 01 010 0018</td> <td>4.5</td> <td>5.5</td> <td>6.6</td> <td>7.5</td> <td>8.5</td> </tr> <tr> <td>21 01 010 0019</td> <td>4.5</td> <td>5.5</td> <td>6.8</td> <td>8.0</td> <td>9.0</td> </tr> <tr> <td>21 01 010 0020</td> <td>5.0</td> <td>6.0</td> <td>7.8</td> <td>9.0</td> <td>10.0</td> </tr> <tr> <td>21 01 010 0021</td> <td>6.5</td> <td>7.5</td> <td>8.0</td> <td>10.0</td> <td>10.8</td> </tr> <tr> <td>21 01 010 0022</td> <td>5.0</td> <td>6.0</td> <td>7.4</td> <td>9.0</td> <td>10.0</td> </tr> <tr> <td>21 01 010 0024</td> <td>5.5</td> <td>6.5</td> <td>8.8</td> <td>10.0</td> <td>10.8</td> </tr> </tbody> </table>		D1	D2	D3	D4	D5	21 01 010 0017	3.5	4.5	6.0	6.5	7.5	21 01 010 0018	4.5	5.5	6.6	7.5	8.5	21 01 010 0019	4.5	5.5	6.8	8.0	9.0	21 01 010 0020	5.0	6.0	7.8	9.0	10.0	21 01 010 0021	6.5	7.5	8.0	10.0	10.8	21 01 010 0022	5.0	6.0	7.4	9.0	10.0	21 01 010 0024	5.5	6.5	8.8	10.0	10.8
	D1	D2	D3	D4	D5																																															
21 01 010 0017	3.5	4.5	6.0	6.5	7.5																																															
21 01 010 0018	4.5	5.5	6.6	7.5	8.5																																															
21 01 010 0019	4.5	5.5	6.8	8.0	9.0																																															
21 01 010 0020	5.0	6.0	7.8	9.0	10.0																																															
21 01 010 0021	6.5	7.5	8.0	10.0	10.8																																															
21 01 010 0022	5.0	6.0	7.4	9.0	10.0																																															
21 01 010 0024	5.5	6.5	8.8	10.0	10.8																																															

Number of contacts

**4+**

Crimp termination  
Shielded

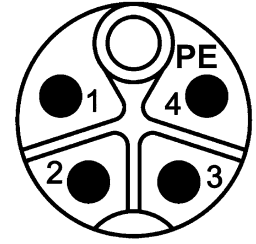

## Technical characteristics

Number of contacts	4
Rated current	12 A
Rated voltage	630 V
Rated impulse voltage	6 kV
Pollution degree	3
Insulation resistance	>10 <sup>8</sup> Ω
Contact resistance	≤10 mΩ
Mating cycles	≥500
Locking type	PushPull
Degree of protection acc. to IEC 60529	IP65 / IP67, when mated
Conductor cross-section	0.5 ... 2.5 mm <sup>2</sup> , 2.5 mm <sup>2</sup> , 1.5 mm <sup>2</sup> , 0.75 mm <sup>2</sup> , 0.5 mm <sup>2</sup>

## Technical characteristics

Conductor cross-section	AWG 20 ... AWG 14, AWG 14, AWG 16, AWG 19, AWG 21
Cable diameter	5.8 ... 13.5 mm
Tightening torque	0.6 Nm
Material (insert)	Polyamide (PA)
Material (hood/housing)	Zinc die-cast
Material (contacts)	Copper alloy
Surface (contacts)	Gold plated

## Specifications and approvals

IEC 61076-2-111

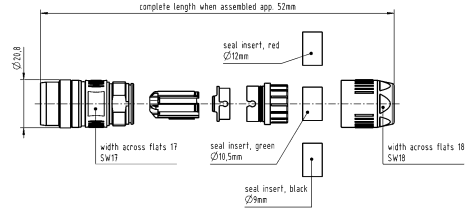
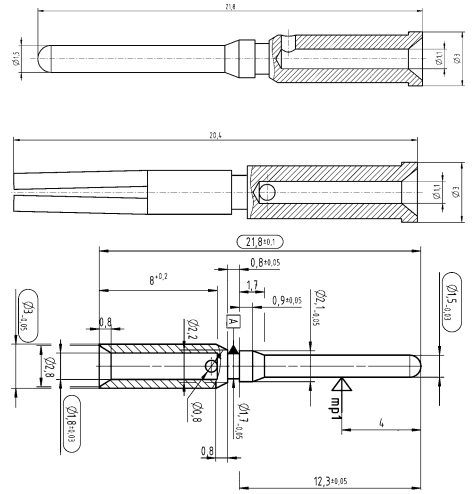
Identification	Conductor cross-section (mm <sup>2</sup> )	Part number		Drawing (dimensions in mm)
		Male	Female	
Circular connectors M12, Power, PushPull, Cable connector, Straight, Crimp termination, Shielded, PushPull locking  <p>Please order crimp contacts separately.</p>	0.5 ... 2.5	21 03 896 1525	21 03 896 2525	
Circular connectors M12, Power, Crimp contact, Turned contacts, Pack contents: 50 pieces	0.5 0.75 1.5 2.5	21 01 100 9962 21 01 100 9963 21 01 100 9937 21 01 100 9938	21 01 100 9964 21 01 100 9965 21 01 100 9939 21 01 100 9940	





Number of contacts

# 3+

Crimp termination  
Shielded

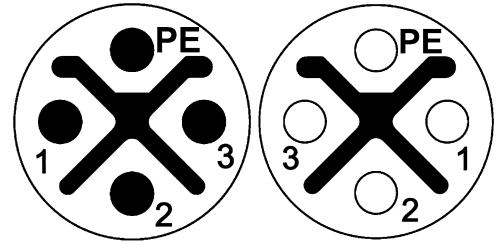

M12

## Technical characteristics

Number of contacts	3
Rated current	12 A
Rated voltage	630 V
Rated impulse voltage	6 kV
Pollution degree	3
Insulation resistance	>10 <sup>8</sup> Ω
Contact resistance	≤10 mΩ
Mating cycles	≥500
Locking type	PushPull
Degree of protection acc. to IEC 60529	IP65 / IP67, when mated
Conductor cross-section	2.5 mm <sup>2</sup> , 1.5 mm <sup>2</sup> , 0.75 mm <sup>2</sup> , 0.5 mm <sup>2</sup>

## Technical characteristics

Conductor cross-section	AWG 14, AWG 16, AWG 19, AWG 21
Cable diameter	5.8 ... 13.5 mm
Tightening torque	0.6 Nm
Material (insert)	Polyamide (PA)
Material (hood/housing)	Zinc die-cast
Material (contacts)	Copper alloy
Surface (contacts)	Gold plated

## Specifications and approvals

IEC 61076-2-111

Identification	Conductor cross-section (mm <sup>2</sup> )	Part number		Drawing (dimensions in mm)
		Male	Female	
Circular connectors M12, Power, PushPull, Cable connector, Straight, Crimp termination, Shielded, PushPull locking Please order crimp contacts separately.		21 03 896 1425	21 03 896 2425	
Circular connectors M12, Power, Crimp contact, Turned contacts, Pack contents: 50 pieces	0.5 0.75 1.5 2.5	21 01 100 9962 21 01 100 9963 21 01 100 9937 21 01 100 9938	21 01 100 9964 21 01 100 9965 21 01 100 9939 21 01 100 9940	

Number of contacts

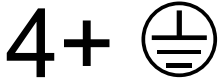

Crimp termination  
Shielded

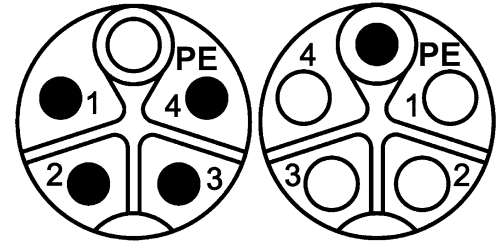

## Technical characteristics

Number of contacts	4
Rated current	12 A
Rated voltage	630 V
Rated impulse voltage	6 kV
Pollution degree	3
Insulation resistance	$>10^8 \Omega$
Contact resistance	$\leq 10 \text{ m}\Omega$
Mating cycles	$\geq 500$
Locking type	Screw locking
Degree of protection acc. to IEC 60529	IP65 / IP67, when mated
Conductor cross-section	0.5 ... 2.5 mm <sup>2</sup> , 2.5 mm <sup>2</sup> , 1.5 mm <sup>2</sup> , 0.75 mm <sup>2</sup> , 0.5 mm <sup>2</sup>

## Technical characteristics

Conductor cross-section	AWG 20 ... AWG 14, AWG 14, AWG 16, AWG 19, AWG 21
Cable diameter	5.8 ... 13.5 mm
Tightening torque	0.6 Nm
Material (insert)	Polyamide (PA)
Material (hood/housing)	Zinc die-cast
Material (contacts)	Copper alloy
Surface (contacts)	Gold plated

## Specifications and approvals

IEC 61076-2-111

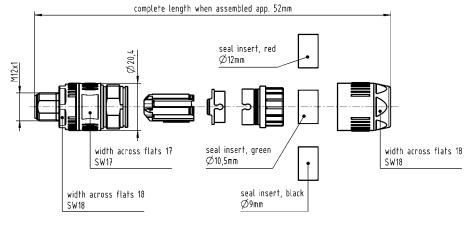
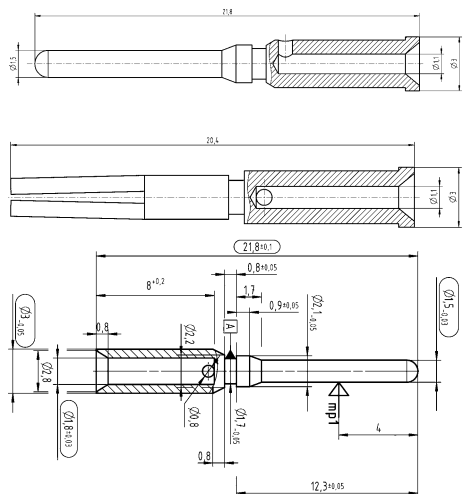
Identification	Conductor cross-section (mm <sup>2</sup> )	Part number		Drawing (dimensions in mm)
		Male	Female	
Circular connectors M12, Power, Cable connector, Straight, Crimp termination, Shielded, Screw locking    Please order crimp contacts separately.	0.5 ... 2.5	21 03 896 1515	21 03 896 2515	
Circular connectors M12, Power, Crimp contact, Turned contacts, Pack contents: 50 pieces	0.5 0.75 1.5 2.5	21 01 100 9962 21 01 100 9963 21 01 100 9937 21 01 100 9938	21 01 100 9964 21 01 100 9965 21 01 100 9939 21 01 100 9940	

Number of contacts

# 4

HARAX® connection technology  
Shielded

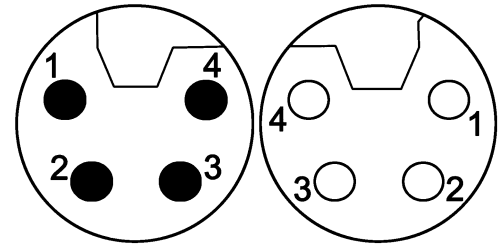

M12

## Technical characteristics

Number of contacts	4
Rated current	12 A
Rated voltage	63 V
Rated impulse voltage	1.5 kV
Pollution degree	3
Insulation resistance	>10 <sup>8</sup> Ω
Contact resistance	≤10 mΩ
Mating cycles	≥100
Locking type	Screw locking
Degree of protection acc. to IEC 60529	IP65 / IP67, when mated
Conductor cross-section	0.75 ... 1.5 mm <sup>2</sup>
Conductor cross-section	AWG 18 ... AWG 16
Cable diameter	5.8 ... 13.5 mm
Tightening torque	0.6 Nm

## Technical characteristics

Material (insert)	Polyamide (PA)
Colour (insert)	Black
Material (hood/housing)	Zinc die-cast
Material (contacts)	Copper alloy
Surface (contacts)	Gold plated
RoHS	compliant

## Specifications and approvals

IEC 61076-2-111

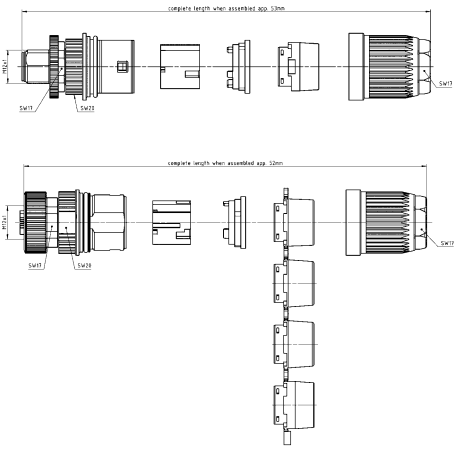

Identification	Conductor cross-section (mm <sup>2</sup> )	Part number		Drawing (dimensions in mm)
		Male	Female	
Circular connectors M12, Power, Cable connector, Straight, HARAX® connection technology, Shielded 	0.75 ... 1.5	21 03 296 1506	21 03 296 2506	



Number of contacts

**4+**

HARAX® connection technology  
Shielded

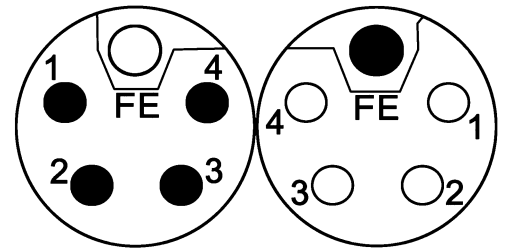

M12

## Technical characteristics

Number of contacts	4
Rated current	12 A
Rated voltage	63 V
Rated impulse voltage	1.5 kV
Pollution degree	3
Insulation resistance	>10 <sup>8</sup> Ω
Contact resistance	≤10 mΩ
Mating cycles	≥100
Locking type	Screw locking
Degree of protection acc. to IEC 60529	IP65 / IP67, when mated
Conductor cross-section	0.75 ... 1.5 mm <sup>2</sup>
Conductor cross-section	AWG 18 ... AWG 16
Cable diameter	5.8 ... 13.5 mm
Tightening torque	0.6 Nm

## Technical characteristics

Material (insert)	Polyamide (PA)
Colour (insert)	Grey
Material (hood/housing)	Zinc die-cast
Material (contacts)	Copper alloy
Surface (contacts)	Gold plated
RoHS	compliant

## Specifications and approvals

IEC 61076-2-111



Identification	Conductor cross-section (mm <sup>2</sup> )	Part number		Drawing (dimensions in mm)
		Male	Female	
Circular connectors M12, Power, Cable connector, Straight, HARAX® connection technology, Shielded 	0.75 ... 1.5	21 03 296 1505	21 03 296 2505	

Number of contacts

**4+**

Crimp termination  
Shielded

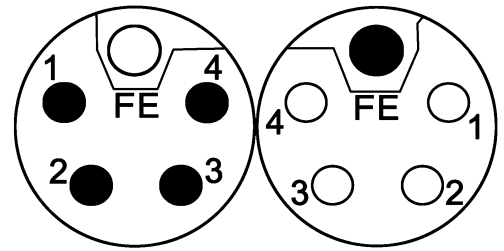

## Technical characteristics

Number of contacts	4
Rated current	16 A
Rated voltage	63 V
Rated impulse voltage	1.5 kV
Pollution degree	3
Insulation resistance	>10 <sup>8</sup> Ω
Contact resistance	≤10 mΩ
Mating cycles	≥500
Locking type	Screw locking
Degree of protection acc. to IEC 60529	IP65 / IP67, when mated
Conductor cross-section	0.5 ... 2.5 mm <sup>2</sup> , 2.5 mm <sup>2</sup> , 1.5 mm <sup>2</sup> , 0.75 mm <sup>2</sup> , 0.5 mm <sup>2</sup>
Conductor cross-section	AWG 20 ... AWG 14, AWG 14, AWG 16, AWG 20, AWG 21
Cable diameter	5.8 ... 13.5 mm
Tightening torque	0.6 Nm

## Technical characteristics

Material (insert)	Polyamide (PA)
Material (hood/housing)	Zinc die-cast
Material (contacts)	Copper alloy
Surface (contacts)	Gold plated
RoHS	compliant, compliant with exemption

## Specifications and approvals

IEC 61076-2-111  
UL 2238 CYJV2.E302521  
CSA-C22.2 No. 182.3 CYJV8.E302521

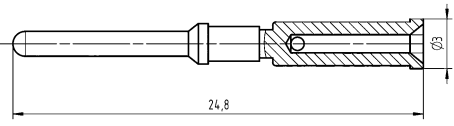

Identification	Conductor cross-section (mm <sup>2</sup> )	Part number		Drawing (dimensions in mm)
		Male	Female	
<p>Circular connectors M12, Power, Cable connector, Straight, Crimp termination, Shielded</p> <p>Please order crimp contacts separately.</p>	0.5 ... 2.5	21 03 896 1505	21 03 896 2505	<p>complete length when assembled approx. 53mm</p> <p>complete length when assembled approx. 52mm</p>
<p>Circular connectors M12, Power, Crimp contact, 23.2 mm length, Turned contacts</p>	0.5 0.75 1.5 2.5	21 01 100 9923 21 01 100 9924 21 01 100 9925 21 01 100 9926	21 01 100 9931 21 01 100 9932 21 01 100 9933 21 01 100 9934	<p>23.2</p> <p>Ø1.5</p> <p>Ø3</p>

Identification	Conductor cross-section (mm <sup>2</sup> )	Part number		Drawing (dimensions in mm)
		Male	Female	
Circular connectors M12, Power, Crimp contact, FE contact, 24.8 mm length, Turned contacts  use with M12 Power female contacts	0.5	21 01 100 9927		
	0.75	21 01 100 9928		
	1.5	21 01 100 9929		
	2.5	21 01 100 9930		

M12

Number of contacts

**4+**

Crimp termination  
Shielded

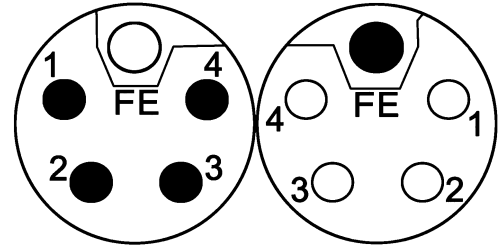

## Technical characteristics

Number of contacts	4
Rated current	16 A
Rated voltage	63 V
Rated impulse voltage	1.5 kV
Pollution degree	3
Insulation resistance	>10 <sup>8</sup> Ω
Contact resistance	≤10 mΩ
Mating cycles	≥500
Locking type	Screw locking
Degree of protection acc. to IEC 60529	IP65 / IP67, when mated
Conductor cross-section	2.5 mm <sup>2</sup> , 1.5 mm <sup>2</sup> , 0.75 mm <sup>2</sup> , 0.5 mm <sup>2</sup>
Conductor cross-section	AWG 14, AWG 16, AWG 19, AWG 21

## Technical characteristics

Cable diameter	5.8 ... 13.5 mm
Tightening torque	0.6 Nm
Material (insert)	Polyamide (PA)
Material (hood/housing)	Zinc die-cast
Material (contacts)	Copper alloy
Surface (contacts)	Gold plated

## Specifications and approvals

IEC 61076-2-111



Identification	Conductor cross-section (mm <sup>2</sup> )	Part number		Drawing (dimensions in mm)
		Male	Female	
Circular connectors M12, Power, Cable connector, Straight, Crimp termination, Shielded, Screw locking Please order crimp contacts separately.		21 03 896 1510	21 03 896 2510	
Circular connectors M12, Power, Crimp contact, Turned contacts, Pack contents: 50 pieces	0.5 0.75 1.5 2.5	21 01 100 9962 21 01 100 9963 21 01 100 9937 21 01 100 9938	21 01 100 9964 21 01 100 9965 21 01 100 9939 21 01 100 9940	

C03  
12  
·  
80

Number of contacts

**3+**

Crimp termination  
Shielded

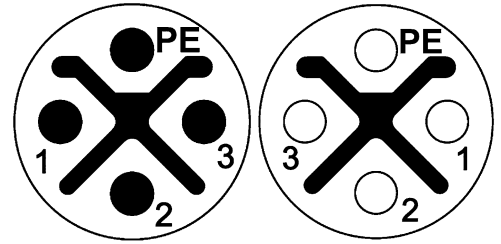

M12

## Technical characteristics

Number of contacts	3
Rated current	12 A
Rated voltage	630 V
Rated impulse voltage	6 kV
Pollution degree	3
Insulation resistance	>10 <sup>8</sup> Ω
Contact resistance	≤10 mΩ
Mating cycles	≥500
Locking type	Screw locking
Degree of protection acc. to IEC 60529	IP65 / IP67, when mated
Conductor cross-section	2.5 mm <sup>2</sup> , 1.5 mm <sup>2</sup> , 0.75 mm <sup>2</sup> , 0.5 mm <sup>2</sup>

## Technical characteristics

Conductor cross-section	AWG 14, AWG 16, AWG 19, AWG 21
Cable diameter	5.8 ... 13.5 mm
Tightening torque	0.6 Nm
Material (insert)	Polyamide (PA)
Material (hood/housing)	Zinc die-cast
Material (contacts)	Copper alloy
Surface (contacts)	Gold plated

## Specifications and approvals

IEC 61076-2-111

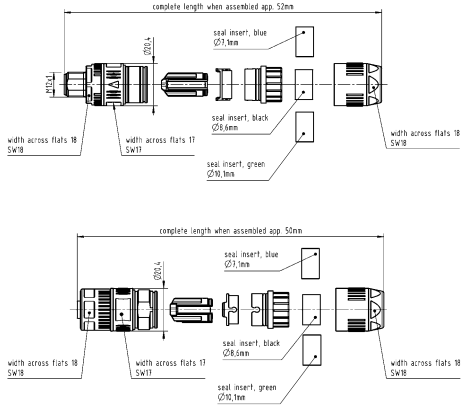
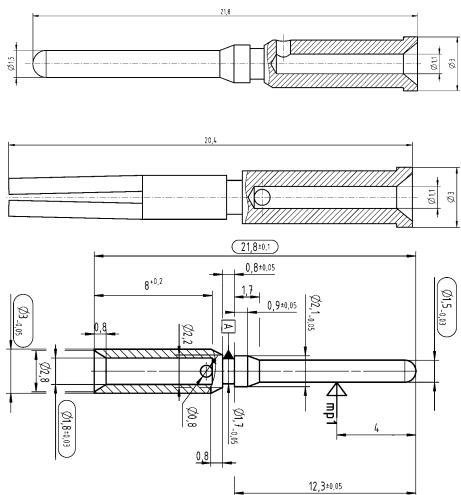
Identification	Conductor cross-section (mm <sup>2</sup> )	Part number		Drawing (dimensions in mm)
		Male	Female	
Circular connectors M12, Power, Cable connector, Straight, Crimp termination, Shielded, Screw locking   Please order crimp contacts separately.		21 03 896 1415	21 03 896 2415	
Circular connectors M12, Power, Crimp contact, Turned contacts, Pack contents: 50 pieces	0.5 0.75 1.5 2.5	21 01 100 9962 21 01 100 9963 21 01 100 9937 21 01 100 9938	21 01 100 9964 21 01 100 9965 21 01 100 9939 21 01 100 9940	





M12





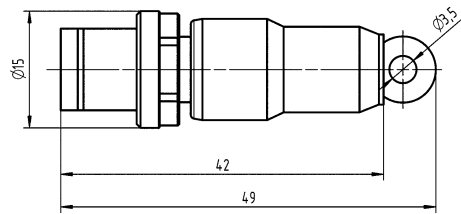

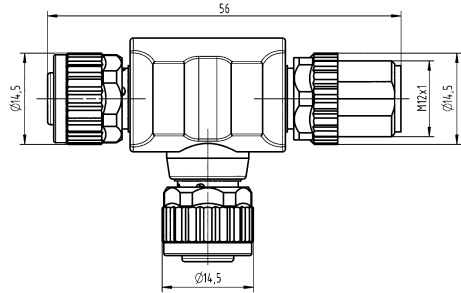
## Technical characteristics

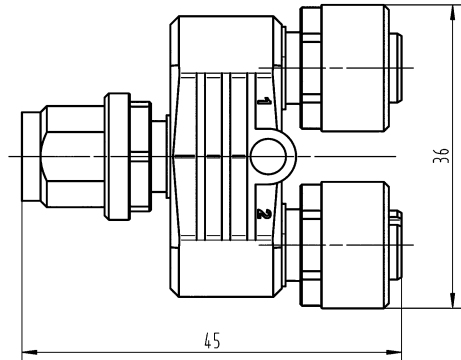
Mating cycles	≥100
Locking type	PushPull
RoHS	compliant, compliant with exemption

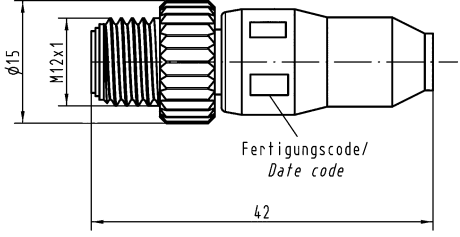

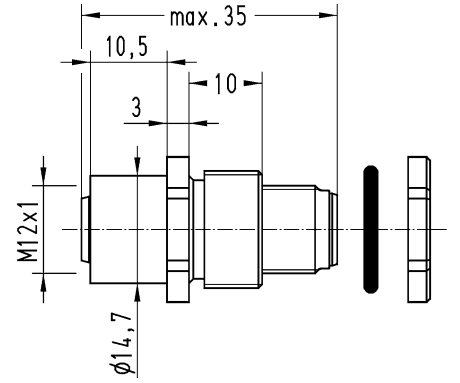

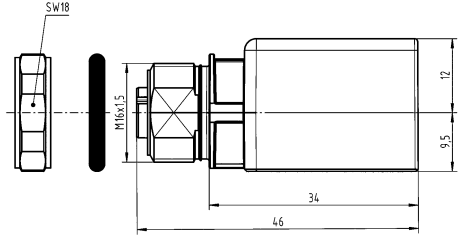
## Specifications and approvals

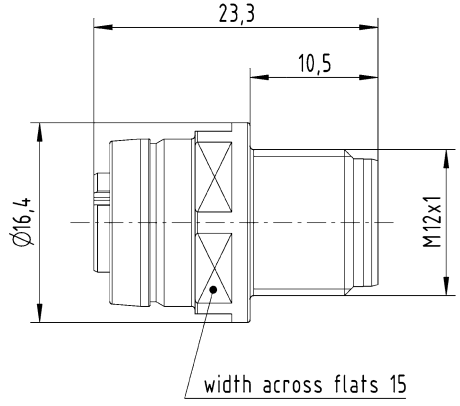

Identification	Part number		Drawing (dimensions in mm)
	Male	Female	
Circular connectors M12, M12-male moving load, A-coding 	21 03 030 1400		
Circular connectors M12, Unshielded, T-splitter, A-coding 	21 03 319 9501		
Circular connectors M12, Unshielded, Y-splitter, A-coding 	21 03 321 9400		

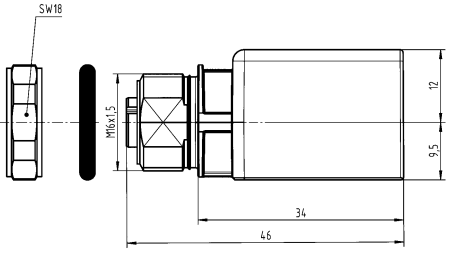
Identification	Part number		Drawing (dimensions in mm)
	Male	Female	
<p>Circular connectors M12, M12-male moving load, B-coding</p> 	21 03 030 1300		 <p>Technical drawing showing dimensions: <math>\phi 15</math>, M12x1, 42, and Fertigungscode/Date code.</p>
<p>Circular connectors M12, M12-male/female panel feed through, B-coding</p> 		21 03 330 1300	 <p>Technical drawing showing dimensions: max. 35, 10,5, 3, 10, M12x1, <math>\phi 14,7</math>.</p>
<p>Circular connectors M12, M12 female-RJ45 panel feed through, D-coding, 4-pin, Straight</p> 		21 03 381 2401	 <p>Technical drawing showing dimensions: SW18, M16x1,5, 12, 9,5, 34, 46.</p>
<p>Circular connectors M12, M12 PushPull adapter, D-coding, 4-pin</p> 		21 03 381 2403	 <p>Technical drawing showing dimensions: 23,3, 10,5, <math>\phi 16,4</math>, M12x1, width across flats 15.</p>

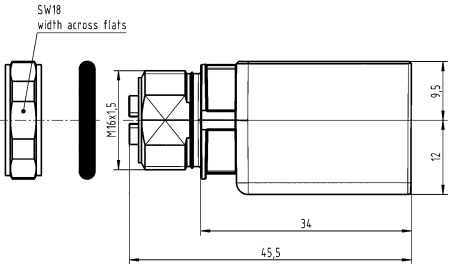
M12

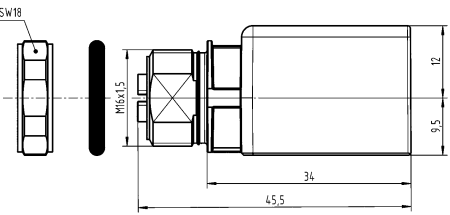
Identification	Part number		Drawing (dimensions in mm)
	Male	Female	
<p>Circular connectors M12, M12 female-RJ45 panel feed through, D-coding, 4-pin, Angled</p> 		21 03 381 4401	
<p>Circular connectors M12, har-speed M12 adapter M12-RJ45, X-coding, Straight, Cat. 6A</p> 		21 03 381 2800	
<p>Circular connectors M12, har-speed M12 adapter M12-RJ45, X-coding, Angled, Cat. 6A</p> 		21 03 381 4800	

## Technical characteristics

Locking type	PushPull, Screw locking
Material (accessories)	Thermoplastic
Colour (accessories)	Black
RoHS	compliant with exemption, compliant





## Specifications and approvals

UL 2238 CYJV2.E302521  
 CSA-C22.2 No. 182.3 CYJV8.E302521

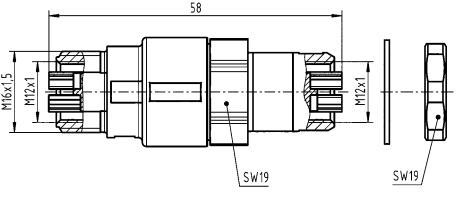

Identification	Part number Female	Drawing (dimensions in mm)
Circular connectors M12, Gender changer, D-coding, 4-pin, Cat. 5	21 03 381 6401	
Circular connectors M12, Gender changer, D-coding, 4-pin or 8-pin	21 03 381 6402	
Circular connectors M12, Gender changer, D-coding, With PushPull, 4-pin, Cat. 5	21 03 381 6403	
Circular connectors M12, Gender changer, D-coding / X-coding, With PushPull, 4-pin or 8-pin	21 03 381 6404	

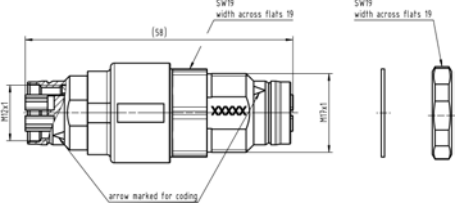
M12

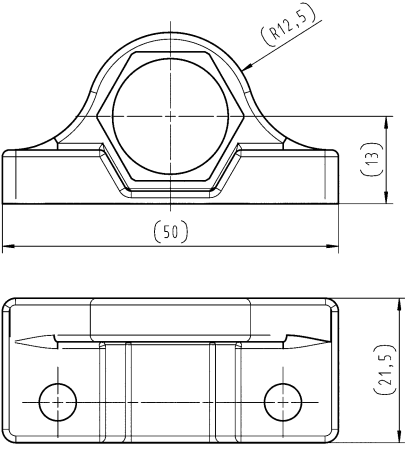
Identification	Part number Female	Drawing (dimensions in mm)
<p>Circular connectors M12, Gender changer, X-coding, Cat. 6<sub>A</sub></p> 	<p>21 03 381 6815</p>	
<p>Circular connectors M12, Gender changer, X-coding, With PushPull, Cat. 6<sub>A</sub></p> 	<p>21 03 381 6816</p>	
<p>Circular connectors M12, Panel mounting parts</p> 	<p>21 01 000 0036</p>	

## Technical characteristics

RoHS

compliant with exemption

Identification

Part number

Drawing  
(dimensions in mm)

Circular connectors M12,  
Slim Design,  
Crimp flange set



HARTING offers to test and define the best crimp flange and ferrule combination for customer specific cables.

21 01 010 0017  
21 01 010 0018  
21 01 010 0019  
21 01 010 0020  
21 01 010 0021  
21 01 010 0022  
21 01 010 0024

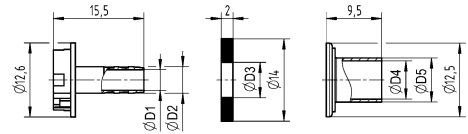

	D1	D2	D3	D4	D5
21 01 010 0017	3.5	4.5	6.0	6.5	7.5
21 01 010 0018	4.5	5.5	6.6	7.5	8.5
21 01 010 0019	4.5	5.5	6.8	8.0	9.0
21 01 010 0020	5.0	6.0	7.8	9.0	10.0
21 01 010 0021	6.5	7.5	8.0	10.0	10.8
21 01 010 0022	5.0	6.0	7.4	9.0	10.0
21 01 010 0024	5.5	6.5	8.8	10.0	10.8





M12

## Technical characteristics

Material (accessories) Thermoplastic

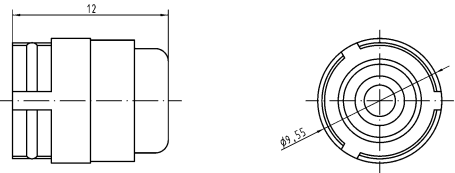
## Technical characteristics

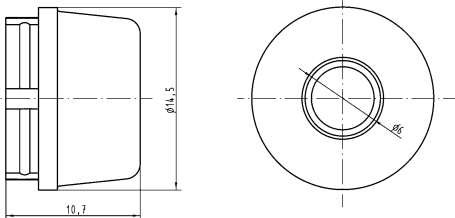
Colour (accessories) Black  
RoHS compliant

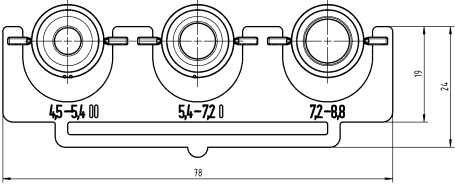
Identification	Cable diameter (mm)	Part number	Drawing (dimensions in mm)
Circular connectors M12, M12-S, Seal, Unshielded 	2.9 ... 4 4 ... 5.1	21 01 010 2011 21 01 010 2001	
Circular connectors M12, M12-L, Seal, Unshielded 	4.7 ... 6 6 ... 8	21 01 010 2015 21 01 010 2007	
Circular connectors M12, M12-L, Set of seals, Shielded 	4.5 ... 8.8	21 01 010 2017	

C03  
12  
-  
88

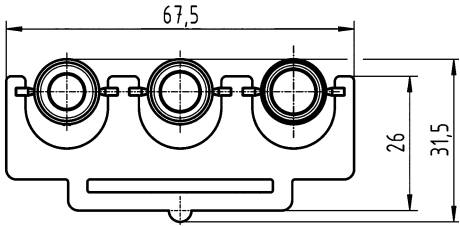
Identification	Cable diameter (mm)	Part number	Drawing (dimensions in mm)
<p>Circular connectors M12, Slim Design, Set of seals, Shielded</p> 	<p>4.5 ... 8.8 5.7 ... 8.8</p>	<p>21 01 010 2038 21 01 010 2028</p>	

M12





M12

## Technical characteristics

Degree of protection acc. to IEC IP65 / IP67, IP67  
60529

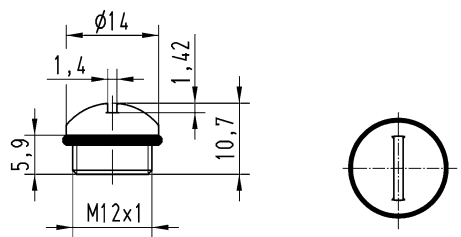
## Technical characteristics

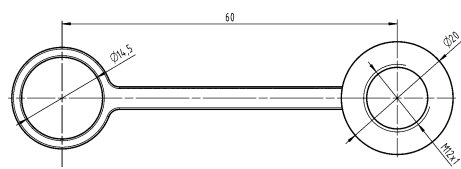
Material (accessories) Thermoplastic  
Colour (accessories) Black  
RoHS compliant

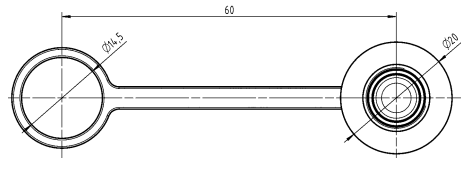
Identification	Part number	Drawing (dimensions in mm)
<p>Circular connectors M12, Cap, IP65 / IP67</p> 	<p>21 01 000 0003</p>	
<p>Circular connectors M12, Cap, for male inserts, with cord, IP67</p> 	<p>21 41 000 0001</p>	
<p>Circular connectors M12, Cap, for female inserts, with cord, IP67</p> 	<p>21 41 000 0002</p>	







## Technical characteristics

Degree of protection acc. to IEC IP65 / IP67  
60529

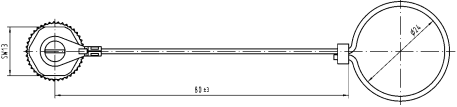
## Technical characteristics

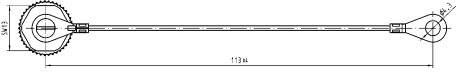
Material (accessories)  
RoHS

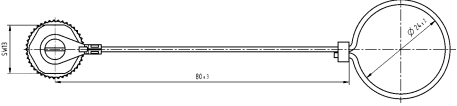
Metal  
compliant with exemption

Identification	Part number	Drawing (dimensions in mm)
Circular connectors M12, Cap, for female inserts, with cord 	21 01 000 0030	
Circular connectors M12, Cap, for female inserts, with cable clip 	21 01 000 0031	
Circular connectors M12, Cap, for male inserts, with cord 	21 01 000 0033	
Circular connectors M12, Cap, for male inserts, with cable clip 	21 01 000 0038	

Contents

Page

M23 Signal inserts .....	<b>C03 23.2</b>
M23 Signal contacts .....	<b>C03 23.16</b>
M23 Signal Hoods/Housings .....	<b>C03 23.17</b>
M23 Power inserts.....	<b>C03 23.20</b>
M23 Power contacts .....	<b>C03 23.25</b>
M23 Power Hoods/Housings .....	<b>C03 23.26</b>

Number of contacts

# 6

Crimp termination

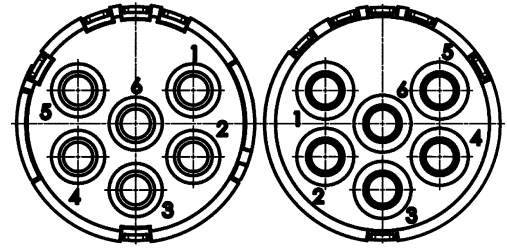

## Technical characteristics

Number of contacts	6
Rated current	20 A
Rated voltage	300 V
Rated impulse voltage	2.5 kV
Pollution degree	3
Insulation resistance	$>10^{10} \Omega$
Limiting temperature	-40 ... +125 °C
Mating cycles	$\geq 500$
Conductor cross-section	0.75 ... 2.5 mm <sup>2</sup>
Material (insert)	Polyamide (PA)

## Technical characteristics

Colour (insert)	White
Material flammability class acc. to UL 94	V-0
RoHS	compliant

## Specifications and approvals

UL 1977 ECBT2.E235076

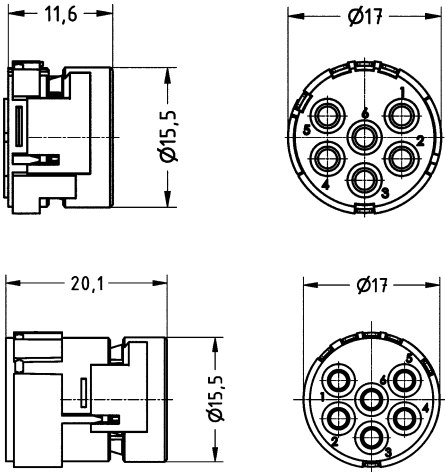
Identification	Conductor cross-section (mm <sup>2</sup> )	Part number		Drawing (dimensions in mm)
		Male	Female	
<p>Circular connectors M23, Signal, Inserts, Crimp termination</p>  <p>Please order crimp contacts separately. 6x 2 mm</p>	0.75 ... 2.5	09 15 106 3001	09 15 106 3101	

Number of contacts

# 6

Solder termination

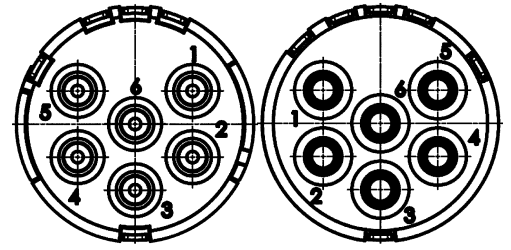

M23

## Technical characteristics

Number of contacts	6
Rated current	20 A
Rated voltage	300 V
Rated impulse voltage	2.5 kV
Pollution degree	3
Insulation resistance	$>10^{10} \Omega$
Limiting temperature	-40 ... +125 °C
Mating cycles	$\geq 500$
Conductor cross-section	2.5 mm <sup>2</sup> max.
Material (insert)	Polyamide (PA)
Colour (insert)	White

## Technical characteristics

Material (contacts)	Copper alloy
Surface (contacts)	Gold plated
Material flammability class acc. to UL 94	V-0
RoHS	compliant with exemption

## Specifications and approvals

UL 1977 ECBT2.E235076

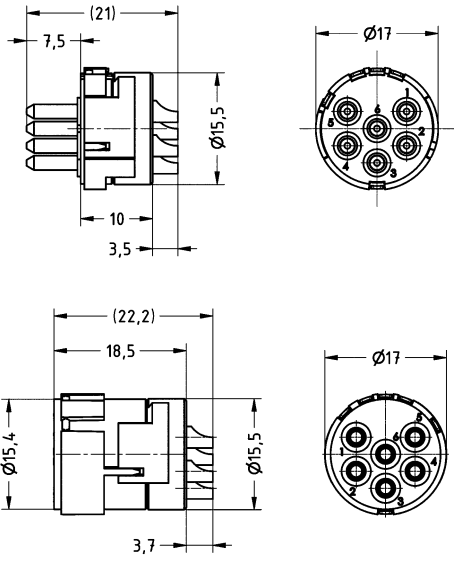
Identification	Conductor cross-section (mm <sup>2</sup> )	Part number		Drawing (dimensions in mm)
		Male	Female	
Circular connectors M23, Signal, Inserts, Solder termination 	2.5 max.	09 15 106 2602	09 15 106 2702	

Number of contacts

# 7

Crimp termination

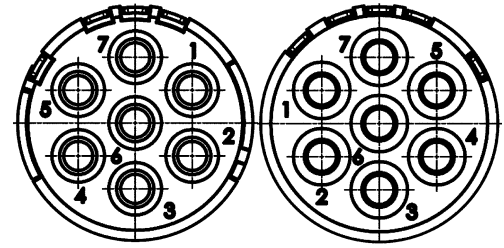

## Technical characteristics

Number of contacts	7
Rated current	20 A
Rated voltage	300 V
Rated impulse voltage	2.5 kV
Pollution degree	3
Insulation resistance	$>10^{10} \Omega$
Limiting temperature	-40 ... +125 °C
Mating cycles	$\geq 500$
Conductor cross-section	0.75 ... 2.5 mm <sup>2</sup>
Material (insert)	Polyamide (PA)

## Technical characteristics

Colour (insert)	White
Material flammability class acc. to UL 94	V-0
RoHS	compliant with exemption

## Specifications and approvals

UL 1977 ECBT2.E235076

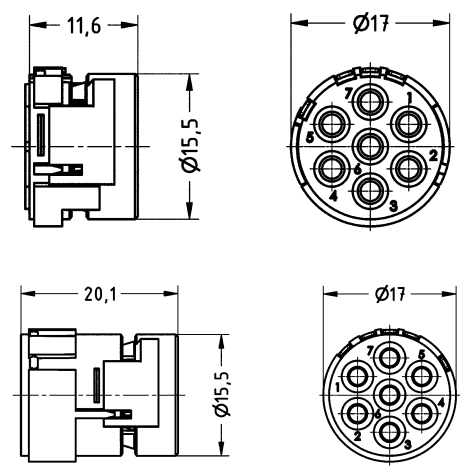
Identification	Conductor cross-section (mm <sup>2</sup> )	Part number		Drawing (dimensions in mm)
		Male	Female	
<p>Circular connectors M23, Signal, Inserts, Crimp termination</p>  <p>Please order crimp contacts separately. 7x 2 mm</p>	0.75 ... 2.5	09 15 107 3001	09 15 107 3101	

Number of contacts

# 7

Solder termination

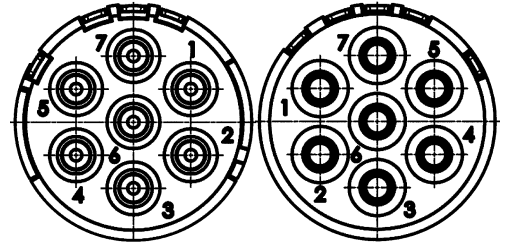

M23

## Technical characteristics

Number of contacts	7
Rated current	20 A
Rated voltage	300 V
Rated impulse voltage	2.5 kV
Pollution degree	3
Insulation resistance	$>10^{10} \Omega$
Limiting temperature	-40 ... +125 °C
Mating cycles	$\geq 500$
Conductor cross-section	2.5 mm <sup>2</sup> max.
Material (insert)	Polyamide (PA)
Colour (insert)	White

## Technical characteristics

Material (contacts)	Copper alloy
Surface (contacts)	Gold plated
Material flammability class acc. to UL 94	V-0
RoHS	compliant with exemption

## Specifications and approvals

UL 1977 ECBT2.E235076

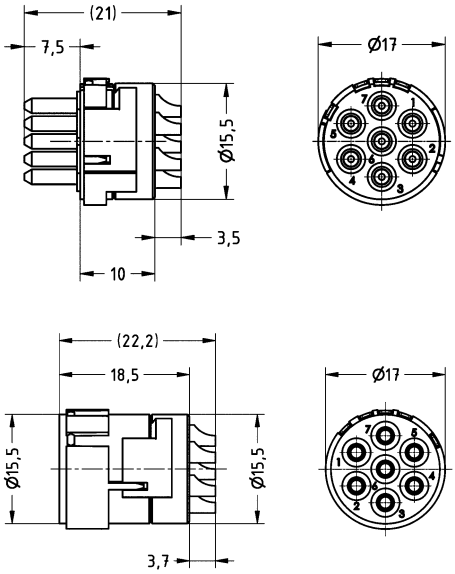
Identification	Conductor cross-section (mm <sup>2</sup> )	Part number		Drawing (dimensions in mm)
		Male	Female	
Circular connectors M23, Signal, Inserts, Solder termination 	2.5 max.	09 15 107 2602	09 15 107 2702	

Number of contacts

# 8

+ 1 additional special contact  
Crimp termination

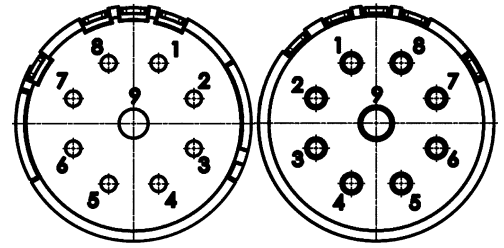

## Technical characteristics

Number of contacts	8
Additional contacts	+ 1 additional special contact
Rated current	8 A
Rated voltage	200 V
Rated impulse voltage	2.5 kV
Pollution degree	3
Rated current (special contact)	20 A
Rated voltage (special contact)	200 V
Rated impulse voltage (special contact)	2.5 kV
Pollution degree (special contact)	3
Insulation resistance	$>10^{10} \Omega$

## Technical characteristics

Limiting temperature	-40 ... +125 °C
Mating cycles	$\geq 500$
Conductor cross-section	0.08 ... 1.5 mm <sup>2</sup>
Material (insert)	Polyamide (PA)
Colour (insert)	White
Material flammability class acc. to UL 94	V-0
RoHS	compliant with exemption

## Specifications and approvals

UL 1977 ECBT2.E235076

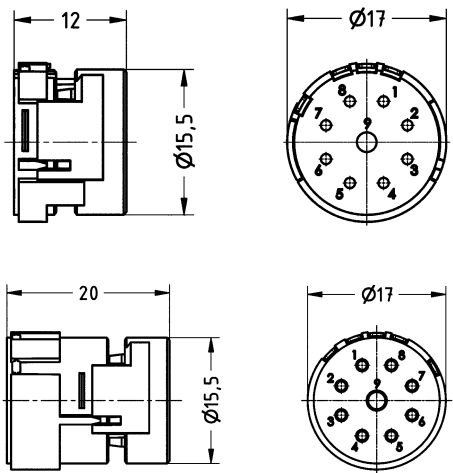
Identification	Conductor cross-section (mm <sup>2</sup> )	Part number		Drawing (dimensions in mm)
		Male	Female	
Circular connectors M23, Signal, Inserts, Crimp termination    Please order crimp contacts separately. 8x 1 mm 1x 2 mm	0.08 ... 1.5	09 15 109 3001	09 15 109 3101	

Number of contacts

# 8

+ 1 additional special contact  
Solder termination

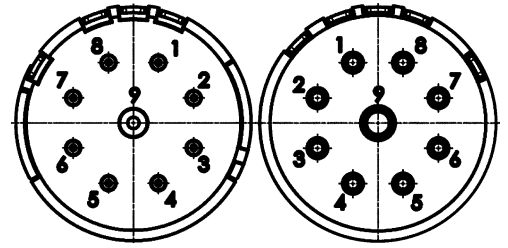

M23

## Technical characteristics

Number of contacts	8
Additional contacts	+ 1 additional special contact
Rated current	8 A
Rated voltage	200 V
Rated impulse voltage	2.5 kV
Pollution degree	3
Rated current (special contact)	20 A
Rated voltage (special contact)	200 V
Rated impulse voltage (special contact)	2.5 kV
Pollution degree (special contact)	3
Insulation resistance	$>10^{10} \Omega$
Limiting temperature	-40 ... +125 °C

## Technical characteristics

Mating cycles	$\geq 500$
Conductor cross-section	1 mm <sup>2</sup> max.
Material (insert)	Polyamide (PA)
Colour (insert)	White
Material (contacts)	Copper alloy
Surface (contacts)	Gold plated
Material flammability class acc. to UL 94	V-0
RoHS	compliant with exemption

## Specifications and approvals

UL 1977 ECBT2.E235076

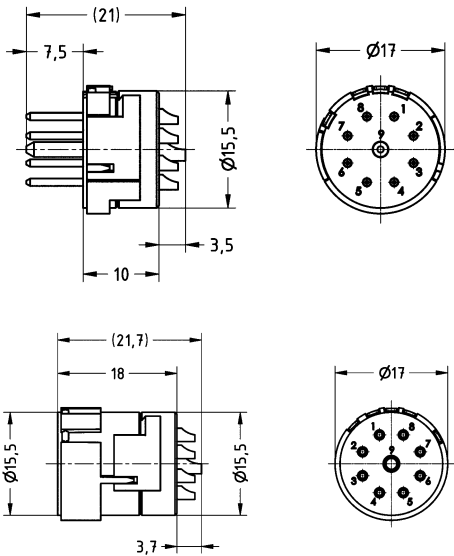
Identification	Conductor cross-section (mm <sup>2</sup> )	Part number		Drawing (dimensions in mm)
		Male	Female	
Circular connectors M23, Signal, Inserts, Solder termination 	1 max.	09 15 109 2602	09 15 109 2702	

Number of contacts

**11+**

Crimp termination

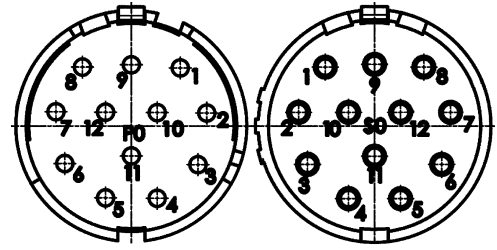

## Technical characteristics

Number of contacts	11
Rated current	8 A
Rated voltage	200 V
Rated impulse voltage	2.5 kV
Pollution degree	3
Insulation resistance	$>10^{10} \Omega$
Limiting temperature	-40 ... +125 °C
Mating cycles	$\geq 500$
Conductor cross-section	0.08 ... 1.5 mm <sup>2</sup>
Material (insert)	Polyamide (PA)

## Technical characteristics

Colour (insert)	Grey
Material flammability class acc. to UL 94	V-0
RoHS	compliant with exemption

## Specifications and approvals

UL 1977 ECBT2.E235076

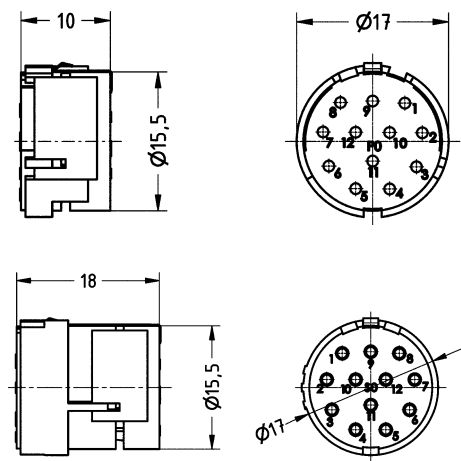
Identification	Conductor cross-section (mm <sup>2</sup> )	Part number		Drawing (dimensions in mm)
		Male	Female	
Circular connectors M23, Signal, Inserts, Crimp termination  Please order crimp contacts separately. 12x 1 mm	0.08 ... 1.5	09 15 112 3021	09 15 112 3121	

Number of contacts

**11+**

Solder termination

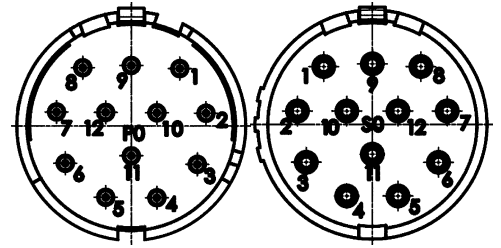

M23

## Technical characteristics

Number of contacts	11
Rated current	8 A
Rated voltage	200 V
Rated impulse voltage	2.5 kV
Pollution degree	3
Insulation resistance	$>10^{10} \Omega$
Limiting temperature	-40 ... +125 °C
Mating cycles	$\geq 500$
Conductor cross-section	1 mm <sup>2</sup> max.
Material (insert)	Polyamide (PA)
Colour (insert)	Grey

## Technical characteristics

Material (contacts)	Copper alloy
Surface (contacts)	Gold plated
Material flammability class acc. to UL 94	V-0
RoHS	compliant with exemption

## Specifications and approvals

UL 1977 ECBT2.E235076

Identification	Conductor cross-section (mm <sup>2</sup> )	Part number		Drawing (dimensions in mm)
		Male	Female	
Circular connectors M23, Signal, Inserts, Solder termination 	1 max.	09 15 112 2622	09 15 112 2722	

Number of contacts

# 12

Crimp termination

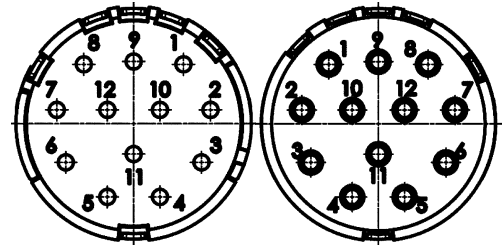

## Technical characteristics

Number of contacts	12
Rated current	8 A
Rated voltage	200 V
Rated impulse voltage	2.5 kV
Pollution degree	3
Insulation resistance	$>10^{10} \Omega$
Limiting temperature	-40 ... +125 °C
Mating cycles	$\geq 500$
Conductor cross-section	0.08 ... 1.5 mm <sup>2</sup>
Material (insert)	Polyamide (PA)

## Technical characteristics

Colour (insert)	White
Material flammability class acc. to UL 94	V-0
RoHS	compliant with exemption, compliant

## Specifications and approvals

UL 1977 ECBT2.E235076

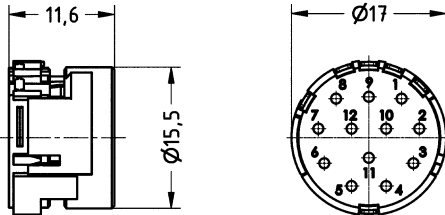
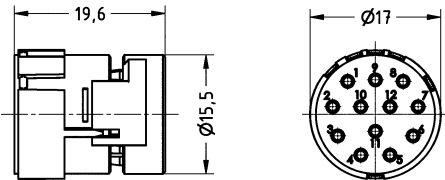
Identification	Conductor cross-section (mm <sup>2</sup> )	Part number		Drawing (dimensions in mm)
		Male	Female	
Circular connectors M23, Signal, Inserts, Crimp termination  <p>Please order crimp contacts separately. 12x 1 mm</p>	0.08 ... 1.5	09 15 112 3001	09 15 112 3101	 
Circular connectors M23, Signal, Inserts, Marking in opposite direction, Crimp termination Please order crimp contacts separately. 12x 1 mm	0.08 ... 1.5	09 15 112 3011	09 15 112 3111	

Number of contacts

# 12

Solder termination

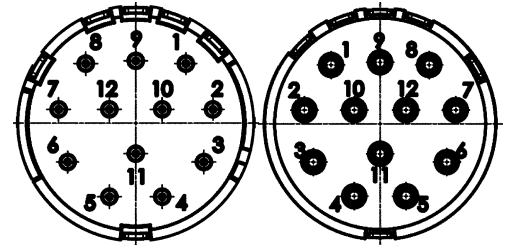

M23

## Technical characteristics

Number of contacts	12
Rated current	8 A
Rated voltage	200 V
Rated impulse voltage	2.5 kV
Pollution degree	3
Insulation resistance	$>10^{10} \Omega$
Limiting temperature	-40 ... +125 °C
Mating cycles	$\geq 500$
Conductor cross-section	1 mm <sup>2</sup> max.
Material (insert)	Polyamide (PA)
Colour (insert)	White

## Technical characteristics

Material (contacts)	Copper alloy
Surface (contacts)	Gold plated
Material flammability class acc. to UL 94	V-0
RoHS	compliant with exemption, compliant

## Specifications and approvals

UL 1977 ECBT2.E235076

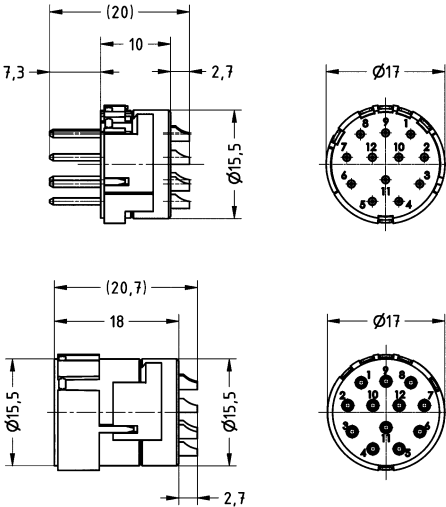
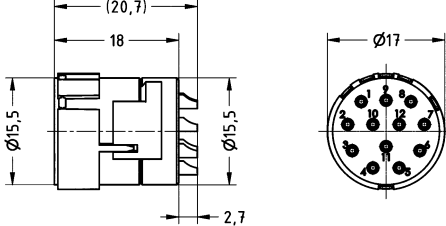
Identification	Conductor cross-section (mm <sup>2</sup> )	Part number		Drawing (dimensions in mm)
		Male	Female	
Circular connectors M23, Signal, Inserts, Solder termination 	1 max.	09 15 112 2602	09 15 112 2702	
Circular connectors M23, Signal, Inserts, Marking in opposite direction, Solder termination	1 max.	09 15 112 2612	09 15 112 2712	

Number of contacts

# 17

Crimp termination

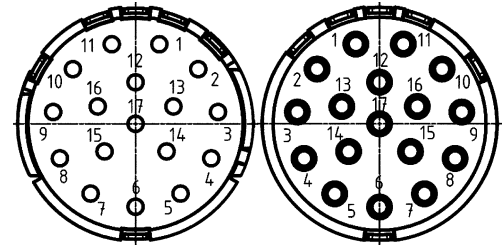

## Technical characteristics

Number of contacts	17
Rated current	8 A
Rated voltage	160 V
Rated impulse voltage	1.5 kV
Pollution degree	3
Insulation resistance	>10 <sup>6</sup> Ω
Limiting temperature	-40 ... +125 °C
Mating cycles	≥500
Conductor cross-section	0.08 ... 1.5 mm <sup>2</sup>
Material (insert)	Polyamide (PA)

## Technical characteristics

Colour (insert)	White
Material flammability class acc. to UL 94	V-0
RoHS	compliant with exemption

## Specifications and approvals

UL 1977 ECBT2.E235076

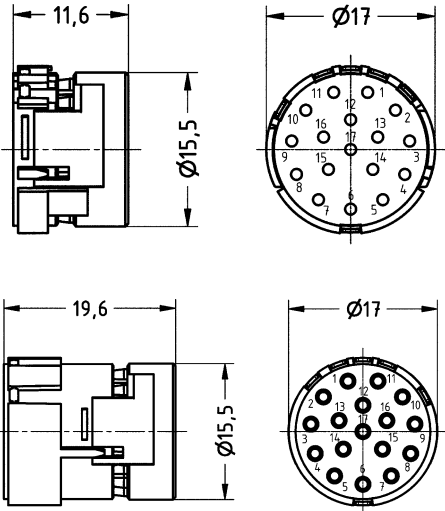
Identification	Conductor cross-section (mm <sup>2</sup> )	Part number		Drawing (dimensions in mm)
		Male	Female	
Circular connectors M23, Signal, Inserts, Crimp termination  Please order crimp contacts separately. 17x 1 mm	0.08 ... 1.5	09 15 117 3001	09 15 117 3101	

Number of contacts

# 17

Solder termination

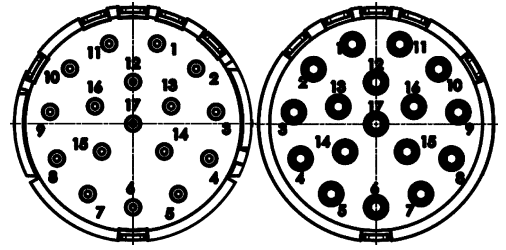

M23

## Technical characteristics

Number of contacts	17
Rated current	8 A
Rated voltage	160 V
Rated impulse voltage	1.5 kV
Pollution degree	3
Insulation resistance	>10 <sup>6</sup> Ω
Limiting temperature	-40 ... +125 °C
Mating cycles	≥500
Conductor cross-section	1 mm <sup>2</sup> max.
Material (insert)	Polyamide (PA)
Colour (insert)	White

## Technical characteristics

Material (contacts)	Copper alloy
Surface (contacts)	Gold plated
Material flammability class acc. to UL 94	V-0
RoHS	compliant with exemption

## Specifications and approvals

UL 1977 ECBT2.E235076

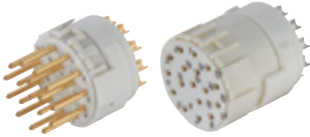
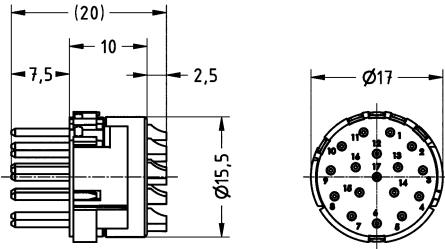
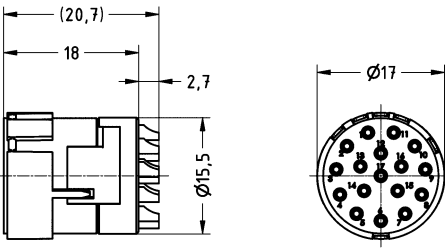
Identification	Conductor cross-section (mm <sup>2</sup> )	Part number		Drawing (dimensions in mm)
		Male	Female	
Circular connectors M23, Signal, Inserts, Solder termination 	1 max.	09 15 117 2602	09 15 117 2702	 

Number of contacts

# 16

+ 3 additional special contacts  
Crimp termination

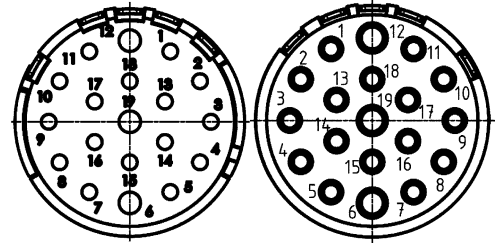

## Technical characteristics

Number of contacts	16
Additional contacts	+ 3 additional special contacts
Rated current	8 A
Rated voltage	100 V
Rated impulse voltage	1.5 kV
Pollution degree	3
Rated current (special contact)	10 A
Rated voltage (special contact)	100 V
Rated impulse voltage (special contact)	1.5 kV
Pollution degree (special contact)	3
Insulation resistance	>10 <sup>6</sup> Ω

## Technical characteristics

Limiting temperature	-40 ... +125 °C
Mating cycles	≥500
Conductor cross-section	0.08 ... 1.5 mm <sup>2</sup>
Material (insert)	Polyamide (PA)
Colour (insert)	White
Material flammability class acc. to UL 94	V-0
RoHS	compliant with exemption

## Specifications and approvals

UL 1977 ECBT2.E235076

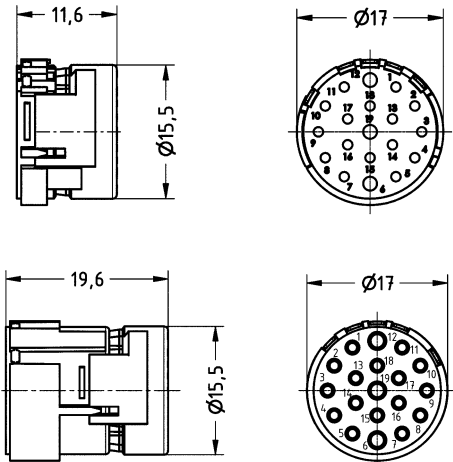
Identification	Conductor cross-section (mm <sup>2</sup> )	Part number		Drawing (dimensions in mm)
		Male	Female	
Circular connectors M23, Signal, Inserts, Crimp termination    Please order crimp contacts separately. 16x 1 mm 3x 1.5 mm	0.08 ... 1.5	09 15 119 3001	09 15 119 3101	

Number of contacts

# 16

+ 3 additional special contacts  
Solder termination

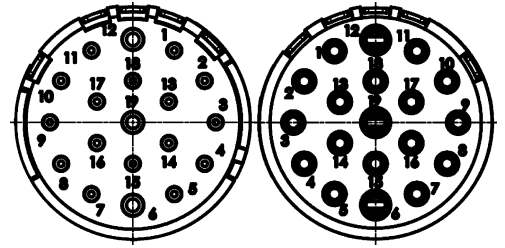

M23

## Technical characteristics

Number of contacts	16
Additional contacts	+ 3 additional special contacts
Rated current	8 A
Rated voltage	100 V
Rated impulse voltage	1.5 kV
Pollution degree	3
Rated current (special contact)	10 A
Rated voltage (special contact)	100 V
Rated impulse voltage (special contact)	1.5 kV
Pollution degree (special contact)	3
Insulation resistance	>10 <sup>6</sup> Ω
Limiting temperature	-40 ... +125 °C

## Technical characteristics

Mating cycles	≥500
Conductor cross-section	1 mm <sup>2</sup> max.
Material (insert)	Polyamide (PA)
Colour (insert)	White
Material (contacts)	Copper alloy
Surface (contacts)	Gold plated
Material flammability class acc. to UL 94	V-0
RoHS	compliant with exemption

## Specifications and approvals

UL 1977 ECBT2.E235076

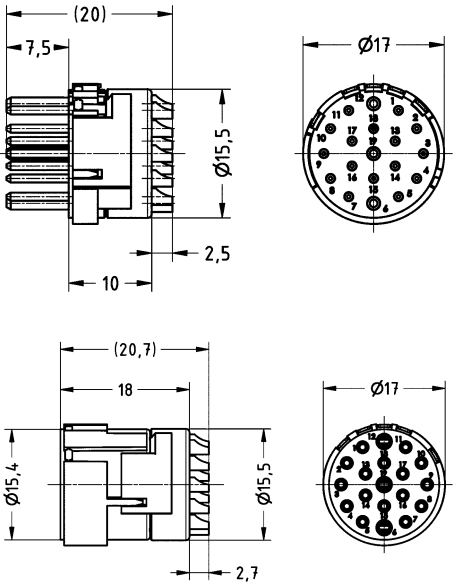
Identification	Conductor cross-section (mm <sup>2</sup> )	Part number		Drawing (dimensions in mm)
		Male	Female	
Circular connectors M23, Signal, Inserts, Solder termination 	1 max.	09 15 119 2602	09 15 119 2702	

M23

## Technical characteristics





Contact resistance	≤3 mΩ
Conductor cross-section	0.08 ... 0.56 mm <sup>2</sup> , 0.14 ... 1 mm <sup>2</sup> , 0.75 ... 1.5 mm <sup>2</sup> , 0.75 ... 2.5 mm <sup>2</sup> , 0.34 ... 1 mm <sup>2</sup> , 0.14 ... 0.56 mm <sup>2</sup> , 0.56 ... 1 mm <sup>2</sup>
Conductor cross-section	AWG 28 ... AWG 20, AWG 26 ... AWG 17, AWG 19 ... AWG 16, AWG 19 ... AWG 14, AWG 22 ... AWG 17, AWG 26 ... AWG 20, AWG 20 ... AWG 17

## Technical characteristics

Material (contacts)	Copper alloy
Surface (contacts)	Gold plated
RoHS	compliant with exemption

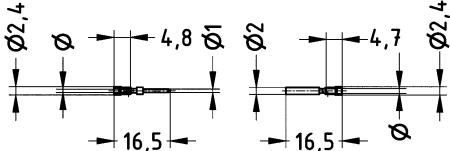
## Specifications and approvals

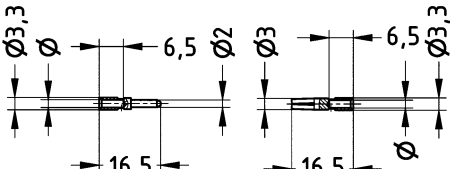
EN 60664-1  
IEC 61984

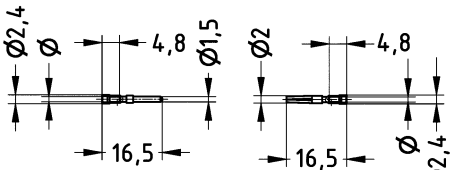
Identification	Conductor cross-section (mm <sup>2</sup> )	Part number		Drawing (dimensions in mm)
		Male	Female	
Circular connectors M23, Signal, Crimp contact, 1 mm, Turned contacts 	0.08 ... 0.56	09 15 100 6101	09 15 100 6201	 <p>Stripping length 4 mm</p>
	0.14 ... 1	09 15 100 6102	09 15 100 6202	
	0.34 ... 1	09 15 100 6103	09 15 100 6203	
	0.75 ... 1.5	09 15 100 6103	09 15 100 6203	
Circular connectors M23, Signal, Crimp contact, 2 mm, Turned contacts 	0.75 ... 2.5	09 15 100 6121	09 15 100 6221	 <p>Stripping length 4 mm</p>
Circular connectors M23, Signal, Crimp contact, 1.5 mm, Turned contacts 	0.14 ... 0.56	09 15 100 6111	09 15 100 6211	 <p>Stripping length 4 mm</p>
	0.14 ... 1 0.56 ... 1		09 15 100 6212	

## Features



- Screw locking
- ComLock rapid locking
- ComLock-S rapid locking (Compatible to Speedtec from TE)

## Technical characteristics

Limiting temperature	-40 ... +125 °C
Locking type	Screw locking, ComLock rapid locking, ComLock-S rapid locking
Degree of protection acc. to IEC 60529	IP67, in locked position, IP69 / IPX9K acc. to ISO 20653
Material (hood/housing)	Copper-zinc alloy
Surface (hood/housing)	Nickel plated
Material (seal)	NBR
Colour (seal)	Black
RoHS	compliant with exemption

## Specifications and approvals

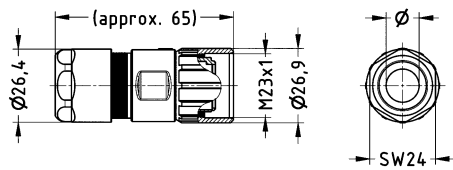

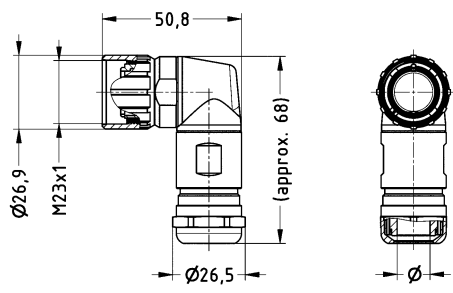



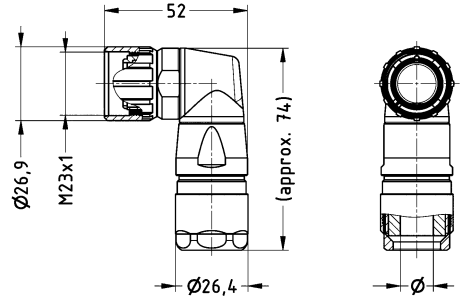

UL 1977 ECBT2.E235076

Identification	Clamping range (mm)	Part number	Drawing (dimensions in mm)
Circular connectors M23, Signal, Hood, EMC version, Top entry 	3 ... 7 7 ... 12 11 ... 17	09 15 100 0401 09 15 100 0402 09 15 100 0403	
Circular connectors M23, Signal, Hood, Angled entry 	7 ... 12	09 15 100 0601	

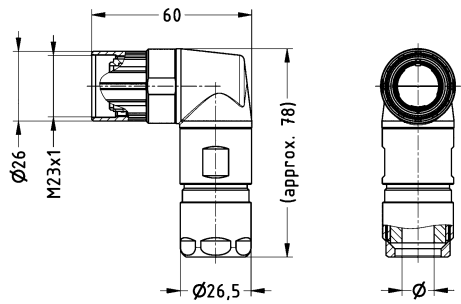

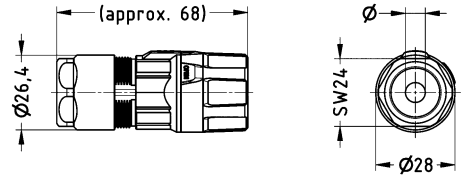

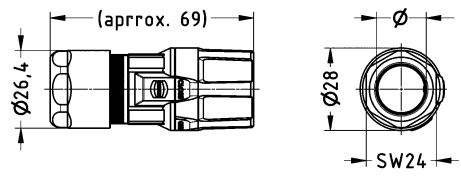
# M23 Signal Hoods/Housings

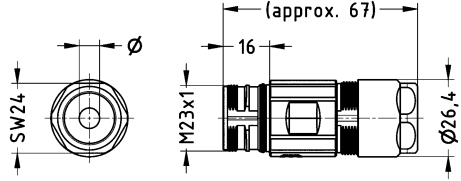

M23

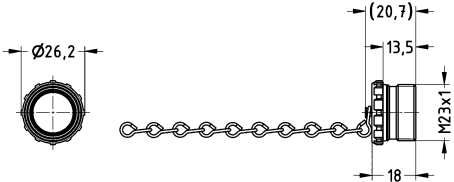
Identification	Clamping range (mm)	Part number	Drawing (dimensions in mm)
Circular connectors M23, Signal, Hood, EMC version, Angled entry 	7 ... 12	09 15 100 0602	
Circular connectors M23, Signal, Hood, EMC version, Rotatable, Angled entry 	7 ... 12	09 15 100 0603	
Circular connectors M23, Signal, Hood, EMC version, Top entry, ComLock rapid locking 	3 ... 7 7 ... 12 11 ... 17	09 15 100 0491 09 15 100 0492 09 15 100 0493	
Circular connectors M23, Signal, Hood, EMC version, Top entry, ComLock-S rapid locking 	3 ... 7 7 ... 12 11 ... 17	09 15 100 0481 09 15 100 0482 09 15 100 0483	
Compatible to Speedtec (TE)			
Circular connectors M23, Signal, Cable to cable housing, EMC version, Top entry 	3 ... 7 7 ... 12 11 ... 17	09 15 100 0701 09 15 100 0702 09 15 100 0703	

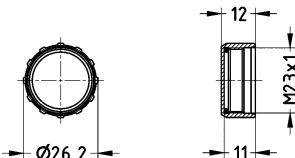
C03  
23  
·  
18

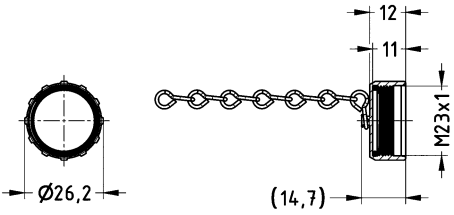
Identification	Clamping range (mm)	Part number	Drawing (dimensions in mm)
<p>Circular connectors M23, Signal, Cover, for hoods, With chain (100 mm)</p> 		09 15 100 9103	
<p>Not compatible to ComLock</p> <p>Circular connectors M23, Signal, Cover, for bulkhead mounted housings, for cable to cable housing</p> 		09 15 100 9101	
<p>Circular connectors M23, Signal, Cover, for bulkhead mounted housings, for cable to cable housing, With chain (70 mm)</p> 		09 15 100 9102	

Number of contacts

**5+**

Crimp termination

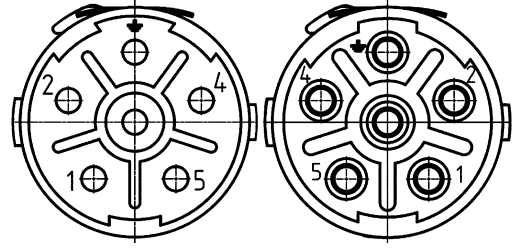

## Technical characteristics

Number of contacts	5
Rated current	28 A
Rated voltage	600 V
Rated impulse voltage	4 kV
Pollution degree	3
Insulation resistance	$>10^{13} \Omega$
Limiting temperature	-40 ... +125 °C
Mating cycles	$\geq 500$
Conductor cross-section	0.14 ... 4 mm <sup>2</sup>
Material (insert)	Polyamide (PA)

## Technical characteristics

Colour (insert)	Blue
Material flammability class acc. to UL 94	V-0
RoHS	compliant

## Specifications and approvals

UL 1977 ECBT2.E235076

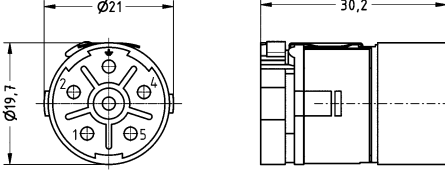
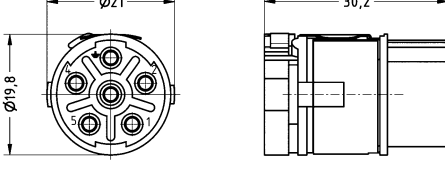
Identification	Conductor cross-section (mm <sup>2</sup> )	Part number		Drawing (dimensions in mm)	
		Male	Female		
Circular connectors M23, Power, Inserts, Crimp termination  Please order crimp contacts separately. 6x 2 mm	0.14 ... 4	09 15 606 3001	09 15 606 3101		

Number of contacts

**3+**

+ 4 additional signal contacts  
Crimp termination

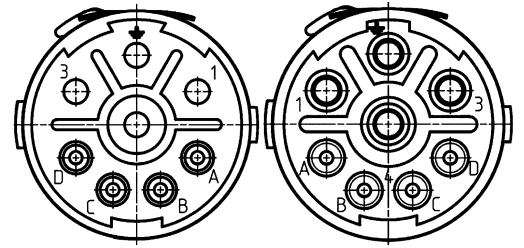

M23

## Technical characteristics

Number of contacts	3
Additional contacts	+ 4 additional signal contacts
Rated current	28 A
Rated voltage	600 V
Rated impulse voltage	4 kV
Pollution degree	3
Rated current (signal)	8 A
Rated voltage (signal)	300 V
Rated impulse voltage (signal)	2.5 kV
Pollution degree (signal)	3
Insulation resistance	>10 <sup>13</sup> Ω
Limiting temperature	-40 ... +125 °C

## Technical characteristics

Mating cycles	≥500
Conductor cross-section	0.14 ... 4 mm <sup>2</sup>
Material (insert)	Polyamide (PA)
Colour (insert)	Blue
Material flammability class acc. to UL 94	V-0
RoHS	compliant

## Specifications and approvals

UL 1977 ECBT2.E235076

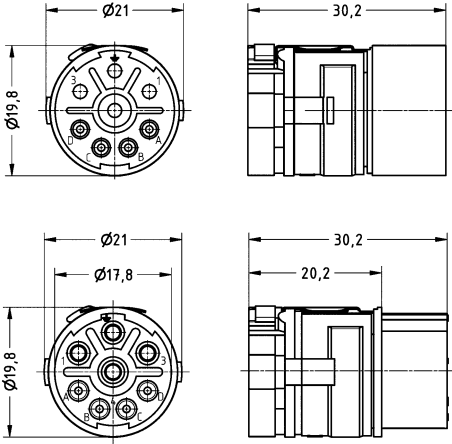
Identification	Conductor cross-section (mm <sup>2</sup> )	Part number		Drawing (dimensions in mm)
		Male	Female	
Circular connectors M23, Power, Inserts, Crimp termination  Please order crimp contacts separately. 4x 2 mm 4x 1 mm	0.14 ... 4	09 15 608 3001	09 15 608 3101	

Number of contacts

**3+**

+ 5 additional signal contacts  
Crimp termination

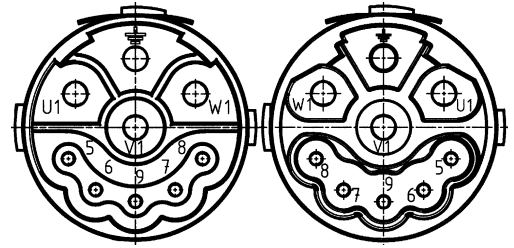

## Technical characteristics

Number of contacts	3
Additional contacts	+ 5 additional signal contacts
Rated current	28 A
Rated voltage	630 V
Rated impulse voltage	4 kV
Pollution degree	3
Rated current (signal)	10 A
Rated voltage (signal)	250 V
Rated impulse voltage (signal)	2.5 kV
Pollution degree (signal)	3
Insulation resistance	>10 <sup>13</sup> Ω
Limiting temperature	-40 ... +125 °C

## Technical characteristics

Mating cycles	≥500
Conductor cross-section	0.14 ... 4 mm <sup>2</sup>
Material (insert)	Polyamide (PA)
Colour (insert)	Blue
Material flammability class acc. to UL 94	V-0
RoHS	compliant

## Specifications and approvals

UL 1977 ECBT2.E235076

Identification	Conductor cross-section (mm <sup>2</sup> )	Part number		Drawing (dimensions in mm)
		Male	Female	
<p>Circular connectors M23, Power, Inserts, Mating face (A), Crimp termination</p> <p>Please order crimp contacts separately. 4x 2 mm 5x 1 mm</p>	0.14 ... 4	09 15 609 3001	09 15 609 3101	

Number of contacts

**3+**

+ 5 additional signal contacts  
Crimp termination

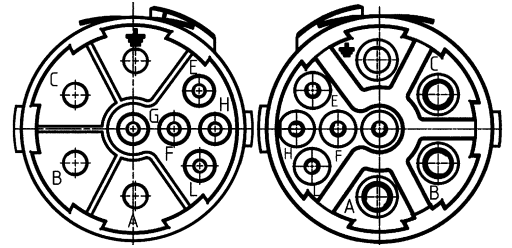

M23

## Technical characteristics

Number of contacts	3
Additional contacts	+ 5 additional signal contacts
Rated current	28 A
Rated voltage	630 V
Rated impulse voltage	4 kV
Pollution degree	3
Rated current (signal)	10 A
Rated voltage (signal)	250 V
Rated impulse voltage (signal)	2.5 kV
Pollution degree (signal)	3
Insulation resistance	>10 <sup>13</sup> Ω
Limiting temperature	-40 ... +125 °C

## Technical characteristics

Mating cycles	≥500
Conductor cross-section	0.14 ... 4 mm <sup>2</sup>
Material (insert)	Polyamide (PA)
Colour (insert)	Blue
Material flammability class acc. to UL 94	V-0
RoHS	compliant

## Specifications and approvals

UL 1977 ECBT2.E235076

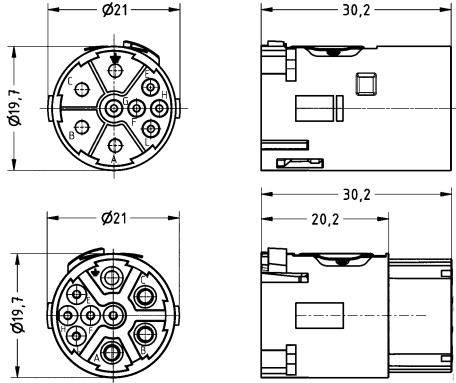
Identification	Conductor cross-section (mm <sup>2</sup> )	Part number		Drawing (dimensions in mm)
		Male	Female	
Circular connectors M23, Power, Inserts, Mating face (B), Crimp termination   Please order crimp contacts separately. 4x 2 mm 5x 1 mm	0.14 ... 4	09 15 609 3011	09 15 609 3111	

Number of contacts

**3+**

+ 4 additional signal contacts + 4 Data  
Crimp termination

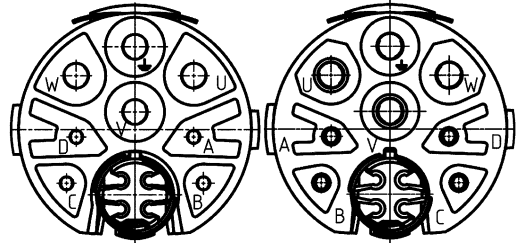

## Technical characteristics

Number of contacts	3
Additional contacts	+ 4 additional signal contacts, + 4 Data
Rated current	28 A
Rated voltage	630 V
Rated impulse voltage	4 kV
Pollution degree	3
Rated current (signal)	8 A
Rated voltage (signal)	300 V
Rated impulse voltage (signal)	2.5 kV
Pollution degree (signal)	3
Rated current (data)	2 A
Rated voltage (data)	60 V
Rated impulse voltage (data)	0.5 kV

## Technical characteristics

Pollution degree (data)	3
Limiting temperature	-40 ... +125 °C
Mating cycles	≥500
Conductor cross-section	0.08 ... 4 mm <sup>2</sup>
Material (insert)	Polyamide (PA)
Colour (insert)	Blue
Material flammability class acc. to UL 94	V-0
RoHS	compliant

## Specifications and approvals

UL 1977 ECBT2.E235076

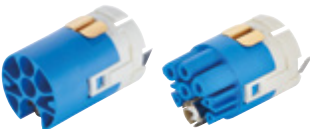
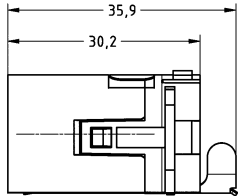
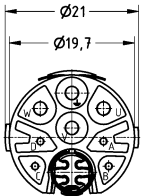
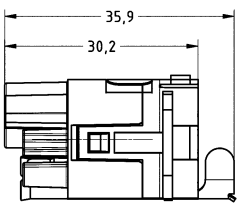
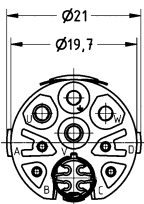



Identification	Conductor cross-section (mm <sup>2</sup> )	Part number		Drawing (dimensions in mm)	
		Male	Female		
Circular connectors M23, Hybrid, Inserts, Crimp termination   Please order crimp contacts separately. 4x 2 mm 4x 1 mm 4x 0.6 mm	0.08 ... 4	09 15 612 3001	09 15 612 3101		
					

## Technical characteristics

Contact resistance	≤3 mΩ
Conductor cross-section	0.08 ... 0.34 mm <sup>2</sup> , 0.14 ... 1 mm <sup>2</sup> , 0.75 ... 2.5 mm <sup>2</sup> , 2.5 ... 4 mm <sup>2</sup>
Material (contacts)	Copper alloy
Surface (contacts)	Gold plated
RoHS	compliant, compliant with exemption

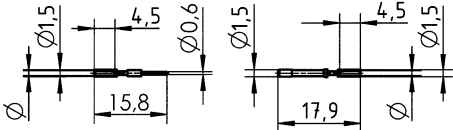
## Specifications and approvals

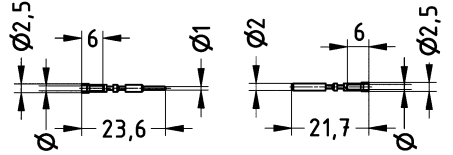
EN 60664-1  
IEC 61984

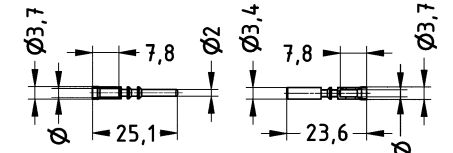
Identification	Conductor cross-section (mm <sup>2</sup> )	Part number		Drawing (dimensions in mm)
		Male	Female	
Circular connectors M23, Power, Crimp contact, 0.6 mm, Turned contacts 	0.08 ... 0.34	09 15 600 6191	09 15 600 6291	 <p>Stripping length 4 mm</p>
Circular connectors M23, Power, Crimp contact, 1 mm, Turned contacts 	0.14 ... 1	09 15 600 6101	09 15 600 6201	 <p>Stripping length 4 mm</p>
Circular connectors M23, Power, Crimp contact, 2 mm, Turned contacts 	0.75 ... 2.5 2.5 ... 4	09 15 600 6121 09 15 600 6122	09 15 600 6221 09 15 600 6222	 <p>Stripping length 7 mm</p>

## Features



- Screw locking
- ComLock rapid locking
- ComLock-S rapid locking (Compatible to Speedtec from TE)





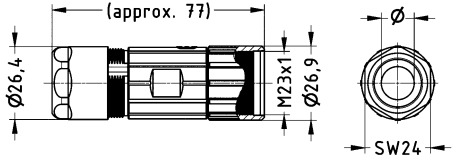

## Technical characteristics

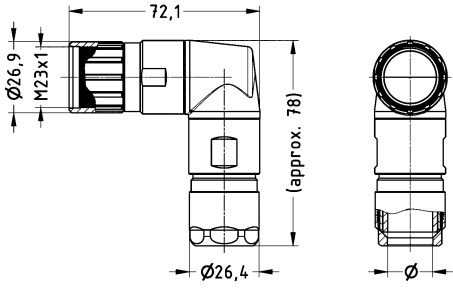
Limiting temperature	-40 ... +125 °C
Locking type	Screw locking, ComLock rapid locking, ComLock-S rapid locking
Degree of protection acc. to IEC 60529	IP67 / IP69 / IPX9K acc. to ISO 20653, in locked position
Material (hood/housing)	Copper-zinc alloy
Surface (hood/housing)	Nickel plated
Material (seal)	NBR
Colour (seal)	Black
RoHS	compliant with exemption, compliant

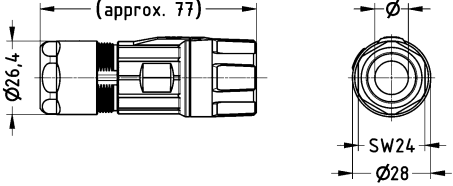
## Specifications and approvals

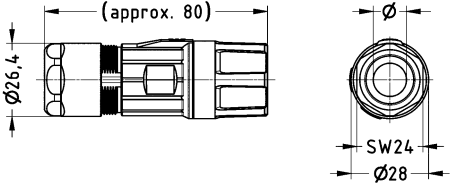
UL 1977 ECBT2.E235076

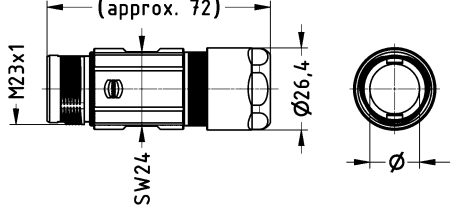
Identification	Clamping range (mm)	Part number	Drawing (dimensions in mm)
Circular connectors M23, Power, Hood, EMC version, Top entry 	7 ... 12 11 ... 17	09 15 600 0402 09 15 600 0403	
Circular connectors M23, Power, Hood, EMC version, Rotatable, Angled entry 	7 ... 12 11 ... 17	09 15 600 0603 09 15 600 0604	

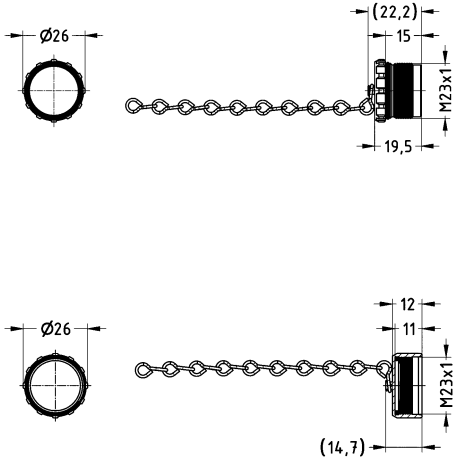
Identification	Clamping range (mm)	Part number	Drawing (dimensions in mm)
<p>Circular connectors M23, Power, Hood, EMC version, Top entry, ComLock rapid locking</p> 	<p>7 ... 12 11 ... 17</p>	<p>09 15 600 0492 09 15 600 0493</p>	
<p>Circular connectors M23, Power, Hood, EMC version, Top entry, ComLock-S rapid locking</p> 	<p>7 ... 12 11 ... 17</p>	<p>09 15 600 0482 09 15 600 0483</p>	
<p>Compatible to Speedtec (TE)</p>			
<p>Circular connectors M23, Power, Cable to cable housing, EMC version, Top entry</p> 	<p>7 ... 12 11 ... 17</p>	<p>09 15 600 0702 09 15 600 0703</p>	
<p>Circular connectors M23, Power, Cover, for hoods, With chain (100 mm)</p>  <p>Not compatible to ComLock</p> <p>Circular connectors M23, Power, Cover, for bulkhead mounted housings, for cable to cable housing, With chain (70 mm)</p> 		<p>09 15 600 9103</p> <p>09 15 600 9102</p>	



Contents

Page

7/8" HARAX® .....

**C03 35.2**

7/8

Number of contacts

5

HARAX® connection technology  
Unshielded

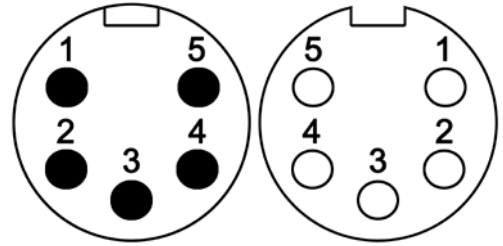

### Technical characteristics

Number of contacts	5
Rated current	10 A
Rated voltage conductor-earth	230 V
Rated voltage conductor-conductor	400 V
Rated impulse voltage	4.8 kV
Pollution degree	3
Insulation resistance	>10 <sup>8</sup> Ω
Contact resistance	≤10 mΩ
Mating cycles	≥100
Wire outer diameter	≤2.8 mm
Locking type	Screw locking

### Technical characteristics

Degree of protection acc. to IEC 60529	IP65 / IP67, when mated
Conductor cross-section	0.75 ... 1.5 mm <sup>2</sup>
Conductor cross-section	AWG 18 ... AWG 16
Cable diameter	6.8 ... 12.5 mm
Tightening torque	1.5 Nm
Material (insert)	Polyamide (PA), Thermoplastic polyurethane (TPU)
Material (hood/housing)	Polyamide (PA), Zinc die-cast, Thermoplastic polyurethane (TPU)
Material (contacts)	Copper alloy
Surface (contacts)	Gold plated
RoHS	compliant with exemption

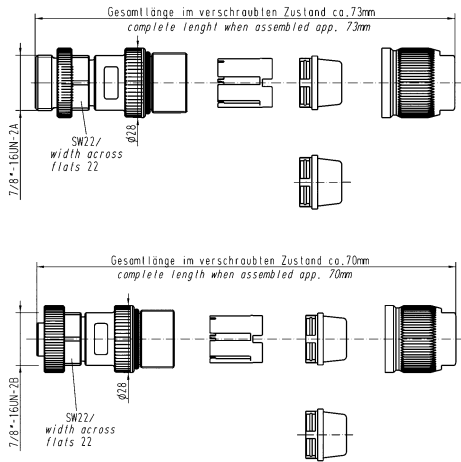
Identification	Conductor cross-section (mm <sup>2</sup> )	Part number		Drawing (dimensions in mm)
		Male	Female	
Circular connectors 7/8", Cable connector, Straight, HARAX® connection technology, Unshielded 	0.75 ... 1.5	21 04 116 1505	21 04 116 2505	

## Contents

## Page

M8 system cables .....	<b>CAB 03.02</b>
M8 system cables D-coding .....	<b>CAB 03.04</b>
M12 system cables A-coding .....	<b>CAB 03.06</b>
M12 system cables B-coding .....	<b>CAB 03.12</b>
M12 system cables D-coding .....	<b>CAB 03.14</b>
M12 system cables X-coding .....	<b>CAB 03.22</b>
M12 system cables L-coding .....	<b>CAB 03.30</b>
7/8" system cables .....	<b>CAB 03.32</b>
M23 system cables, signal .....	<b>CAB 03.34</b>
M23 system cables, power .....	<b>CAB 03.36</b>

Cable

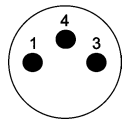

Male, 3 poles

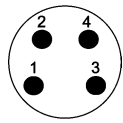

Male, 4 poles

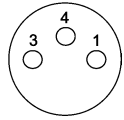

Female, 3 poles

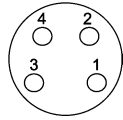

Female, 4 poles



## Technical characteristics

System cables with M8 circular connectors without PE

	3 poles		4 poles	
	PVC	PUR	PVC	PUR
Rated voltage	max. 60 V AC/DC	max. 60 V AC/DC	max. 30 V AC/DC	max. 30 V AC/DC
Rated current / contact	max. 3 A @ +40 °C	max. 3 A @ +40 °C	max. 3 A @ +40 °C	max. 3 A @ +40 °C
Screw locking	M8x1, self securing	M8x1, self securing	M8x1, self securing	M8x1, self securing
Recommended torque	0.4 Nm	0.4 Nm	0.4 Nm	0.4 Nm
Temperature range (working and storage)	-30 °C ... +80 °C	-30 °C ... +80 °C	-30 °C ... +80 °C	-30 °C ... +80 °C
Degree of protection	IP67	IP67	IP67	IP67
Number of wires / wire gauge	3 x 0.25 mm <sup>2</sup>	3 x 0.25 mm <sup>2</sup>	3 x 0.25 mm <sup>2</sup>	3 x 0.25 mm <sup>2</sup>
Conductor insulation	PVC (bn, bu, bk)	PVC (bn, bu, bk)	PVC (bn, wh, bu, bk)	PVC (bn, wh, bu, bk)
Arrangement of insulated strands	32 x Ø 0.1 mm	32 x Ø 0.1 mm	32 x Ø 0.1 mm	32 x Ø 0.1 mm
Sheath	PVC	PUR (UL, CSA)	PVC	PUR (UL, CSA)
Sheath colour	grey	black	grey	black
Outer diameter	Ø 4.40 ± 0.15 mm	Ø 4.40 ± 0.15 mm	Ø 4.70 ± 0.15 mm	Ø 4.40 ± 0.15 mm
Useable as trailing cable	no	yes	no	yes
Halogen free acc. to	–	DIN VDE 0472 part 815	–	DIN VDE 0472 part 815
Flame retardant acc. to	DIN EN 60332-2-2	cUL20549	DIN EN 60332-2-2	cUL20549
Oil-resistant	–	DIN EN 60811-2-1	–	–

	Loading-Plan:		Loading-Plan:
	1 — brown		1 — brown
	3 — blue		2 — white
	4 — black		3 — blue
			4 — black

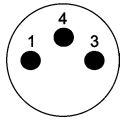

Male, 3 poles

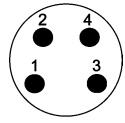

Male, 4 poles

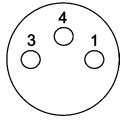

Female, 3 poles

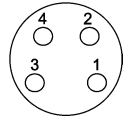

Female, 4 poles



Cable

## Part number definition



### Connector 1

- 80 Male straight
- 81 Female straight
- 82 Male angled
- 83 Female angled

### Connector 2

- 00 No connector
- 80 Male straight
- 81 Female straight
- 82 Male angled
- 83 Female angled

### Number of contacts

- 3 3 poles
- 4 4 poles

### Cable material

- 80 PVC (3 poles)
- 81 PVC (4 poles)
- 88 PUR (3 poles)
- 89 PUR (4 poles)

### Preferred length\*

- 005 0.5 m
- 010 1.0 m
- 015 1.5 m
- 020 2.0 m
- 050 5.0 m
- 075 7.5 m
- 100 10.0 m

\* Other cable lengths on request!

Cable

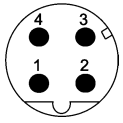

Male, 4 poles

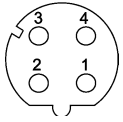

Female, 4 poles



## Technical characteristics

System cables with M8 circular connectors shielded, D-coding

	4 poles PVC	4 poles PUR
Rated voltage	max. 50 V AC/60 V DC	max. 50 V AC/60 V DC
Rated current / contact	max. 4 A @ +40 °C	max. 4 A @ +40 °C
Screw locking	M8x1, self securing	M8x1, self securing
Recommended torque	0.4 Nm	0.4 Nm
Temperature range (working and storage)	-30 °C ... +70 °C	-30 °C ... +70 °C
Degree of protection	IP67	IP67
Number of wires / wire gauge	4 x AWG22	4 x AWG22
Conductor insulation	PE (wh, ye, bu, or)	PE (wh, ye, bu, or)
Arrangement of insulated strands	7 x Ø 0.25 mm	7 x Ø 0.25 mm
Sheath	PVC	PUR
Sheath colour	green	green
Outer diameter	Ø 6.20 ± 0.20 mm	Ø 6.20 ± 0.20 mm
Useable as trailing cable	no	yes
Halogen free acc. to	-	IEC 60754
Flame retardant acc. to	UL 1685	IEC 60332-1-2 and UL 2556 VW1
Oil-resistant	IEC 60811-2-1	IEC 60811-2-1 and UL13

Loading-Plan:

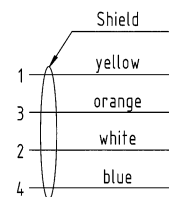
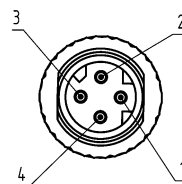

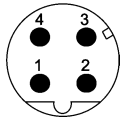

Male, 4 poles

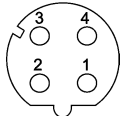

Female, 4 poles



Cable

## Part number definition

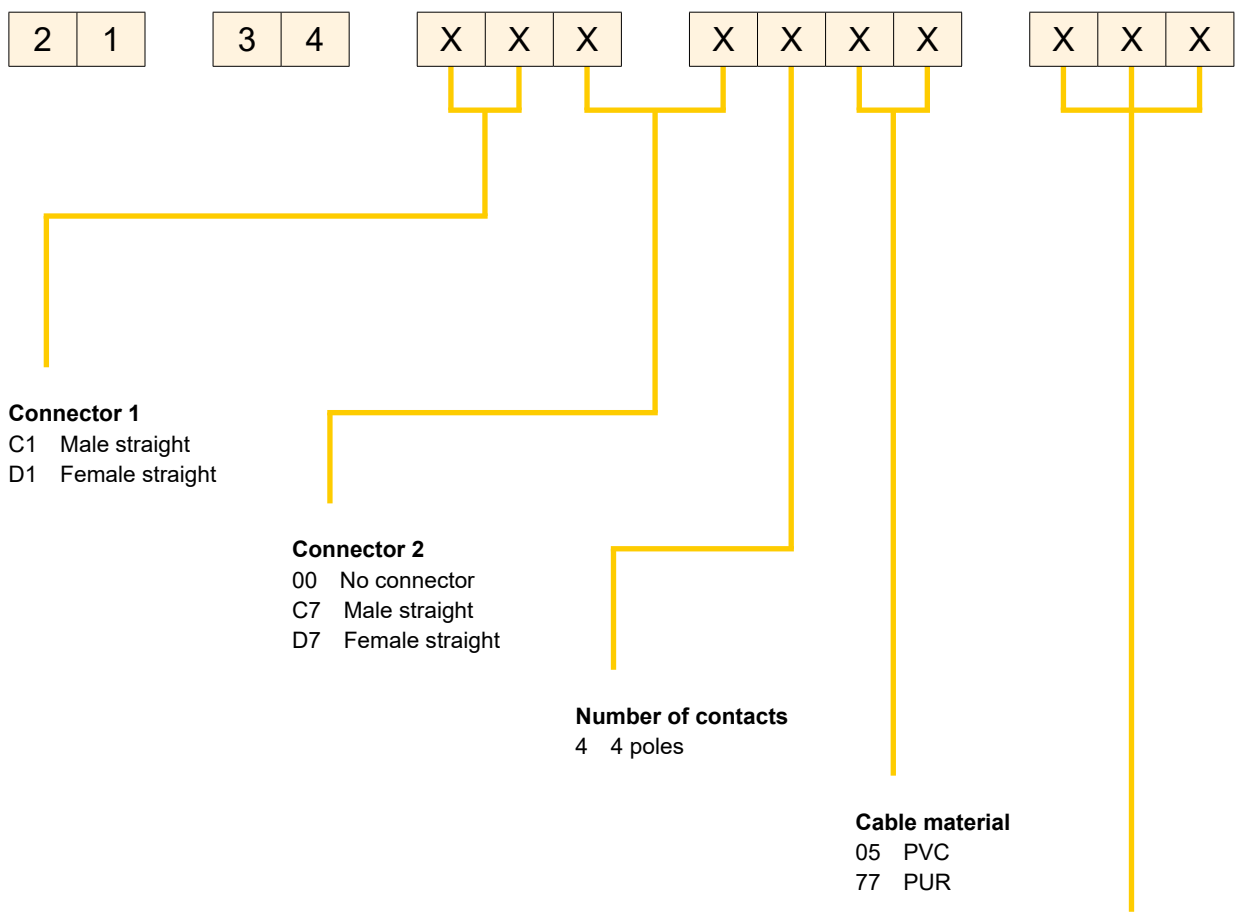

### Preferred length\*

005	0.5 m
010	1.0 m
015	1.5 m
020	2.0 m
050	5.0 m
075	7.5 m
100	10.0 m

\* Other cable lengths on request!

Cable



Male, 3 poles

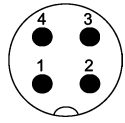

Male, 4 poles

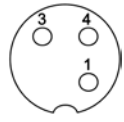

Female, 3 poles

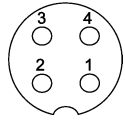

Female, 4 poles



## Technical characteristics

System cables with M12 circular connectors without PE, A-coding

	3 poles		4 poles	
	PVC	PUR	PVC	PUR
Rated voltage	max. 250 V AC/DC	max. 250 V AC/DC	max. 250 V AC/DC	max. 250 V AC/DC
Rated current / contact	max. 4 A @ +40 °C	max. 4 A @ +40 °C	max. 4 A @ +40 °C	max. 4 A @ +40 °C
Screw locking	M12x1, self securing	M12x1, self securing	M12x1, self securing	M12x1, self securing
Recommended torque	0.6 Nm	0.6 Nm	0.6 Nm	0.6 Nm
Temperature range (working and storage)	-30 °C ... +80 °C	-30 °C ... +80 °C	-30 °C ... +80 °C	-30 °C ... +80 °C
Degree of protection	IP67	IP67	IP67	IP67
Number of wires / wire gauge	3 x 0.34 mm <sup>2</sup>	3 x 0.34 mm <sup>2</sup>	4 x 0.34 mm <sup>2</sup>	4 x 0.34 mm <sup>2</sup>
Conductor insulation	PVC (bn, bu, bk)	PP (bn, bu, bk)	PVC (bn, wh, bu, bk)	PP (bn, wh, bu, bk)
Arrangement of insulated strands	42 x Ø 0.1 mm	42 x Ø 0.1 mm	42 x Ø 0.1 mm	42 x Ø 0.1 mm
Sheath	PVC	PUR (UL, CSA)	PVC	PUR (UL, CSA)
Sheath colour	grey	black	grey	black
Outer diameter	Ø 4.4 ± 0.15 mm	Ø 4.4 ± 0.15 mm	Ø 4.7 ± 0.15 mm	Ø 4.7 ± 0.15 mm
Useable as trailing cable	no	yes	no	yes
Halogen free acc. to	–	DIN VDE 0472 part 815	–	DIN VDE 0472 part 815
Flame retardant acc. to	DIN EN 60332-2-2	cUL20549	DIN EN 60332-2-2	cUL20549
Oil-resistant	–	–	–	DIN EN 60811-2-1

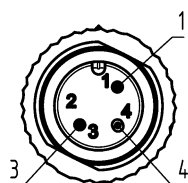

Loading-Plan:

- 1 — brown
- 3 — blue
- 4 — black

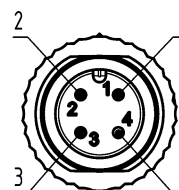

Loading-Plan:

- 1 — brown
- 2 — white
- 3 — blue
- 4 — black



Male, 3 poles

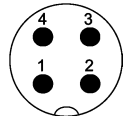

Male, 4 poles

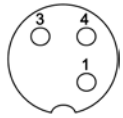

Female, 3 poles

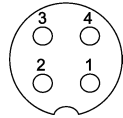

Female, 4 poles



Cable

## Part number definition

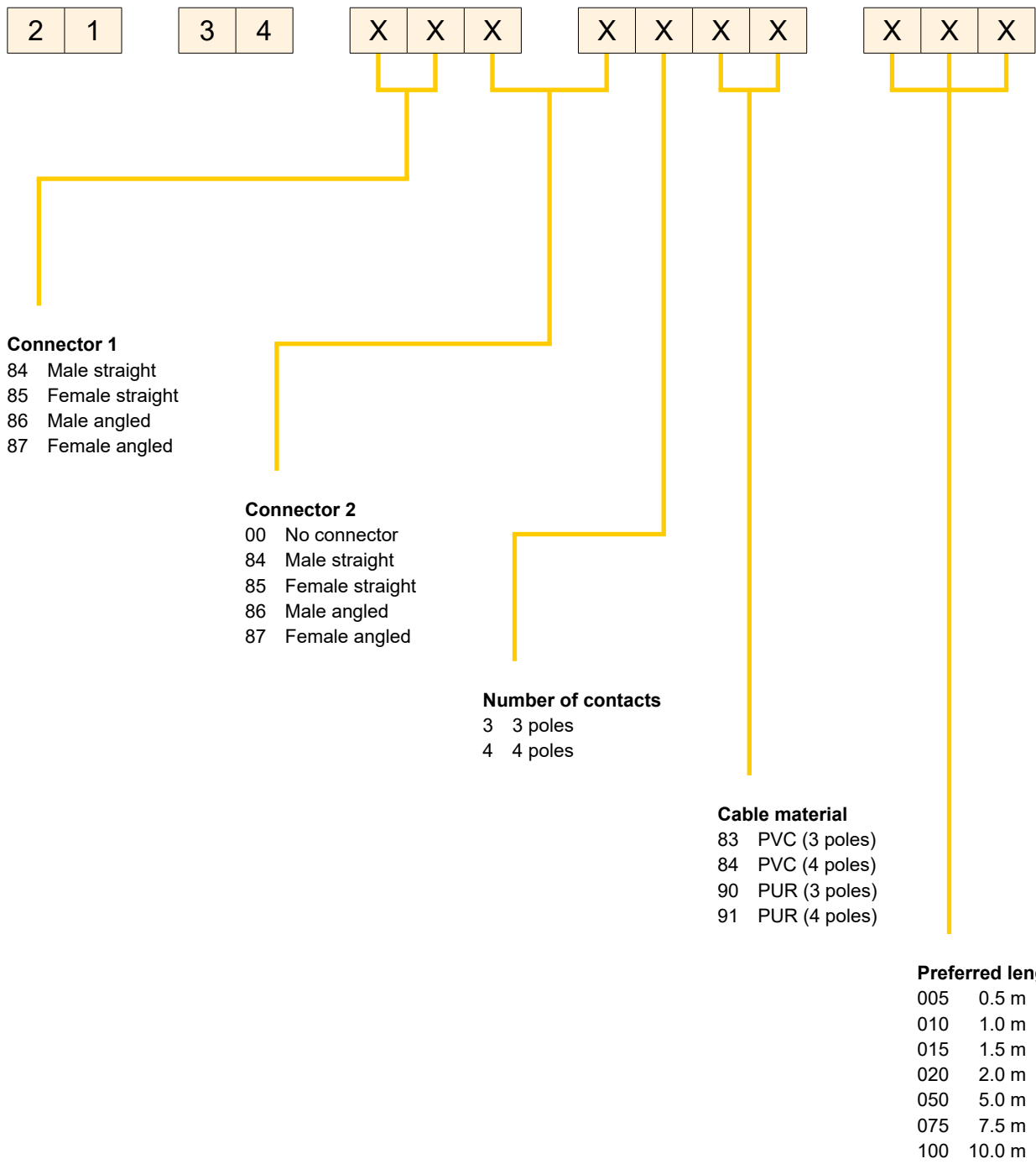

\* Other cable lengths on request!

Cable

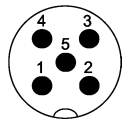

Male, 5 poles

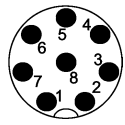

Male, 8 poles

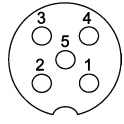

Female, 5 poles

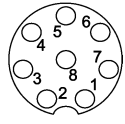

Female, 8 poles



## Technical characteristics

System cables with M12 circular connectors without PE, A-coding

	5 poles	5 poles	8 poles	8 poles
	PVC	PUR	PVC	PUR
Rated voltage	max. 60 V AC/DC	max. 60 V AC/DC	max. 30 V AC/DC	max. 30 V AC/DC
Rated current / contact	max. 4 A @ +40 °C	max. 4 A @ +40 °C	max. 2 A @ +40 °C	max. 2 A @ +40 °C
Screw locking	M12x1, self securing	M12x1, self securing	M12x1, self securing	M12x1, self securing
Recommended torque	0.6 Nm	0.6 Nm	0.6 Nm	0.6 Nm
Temperature range (working and storage)	-30 °C ... +80 °C	-30 °C ... +80 °C	-30 °C ... +80 °C	-30 °C ... +80 °C
Degree of protection	IP67	IP67	IP67	IP67
Number of wires / wire gauge	5 x 0.34 mm <sup>2</sup>	5 x 0.34 mm <sup>2</sup>	8 x 0.25 mm <sup>2</sup>	8 x 0.25 mm <sup>2</sup>
Conductor insulation	PVC (bn, wh, bu, bk, gn/ye)	PP (bn, wh, bu, bk, gn/ye)	PVC (wh, bn, gn, ye, gy, pk, bu, rd)	PP (wh, bn, gn, ye, gy, pk, bu, rd)
Arrangement of insulated strands	42 x Ø 0.1 mm	42 x Ø 0.1 mm	32 x Ø 0.1 mm	32 x Ø 0.1 mm
Sheath	PVC	PUR	PVC	PUR
Sheath colour	grey	black	grey	black
Outer diameter	Ø 5.2 ± 0.15 mm	Ø 5.1 ± 0.15 mm	Ø 6.2 ± 0.2 mm	Ø 6.0 ± 0.2 mm
Useable as trailing cable	no	yes	no	yes
Halogen free acc. to	–	DIN VDE 0472 part 815	–	DIN VDE 0472 part 815
Flame retardant acc. to	DIN EN 60332-2-2	cULus 20549	DIN EN 60332-2-2	cULus 20549
Oil-resistant	–	DIN EN 60811-2-1	–	DIN EN 60811-2-1

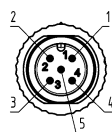

Loading-Plan:

- 1 brown
- 2 white
- 3 blue
- 4 black
- 5 green-yellow

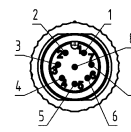

Loading-Plan:

- 1 white
- 2 brown
- 3 green
- 4 yellow
- 5 grey
- 6 pink
- 7 blue
- 8 red

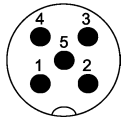

Male, 5 poles

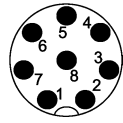

Male, 8 poles

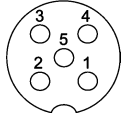

Female, 5 poles

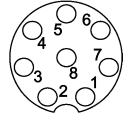

Female, 8 poles



Cable

## Part number definition



### Connector 1

- 84 Male straight
- 85 Female straight
- 86 Male angled
- 87 Female angled

### Connector 2

- 00 No connector
- 84 Male straight
- 85 Female straight
- 86 Male angled
- 87 Female angled

### Number of contacts

- 5 5 poles
- 8 8 poles

### Cable material

- 70 PUR (8 poles)
- 82 PVC (8 poles)
- 85 PVC (5 poles)
- 92 PUR (5 poles)

### Preferred length\*

- 005 0.5 m
- 010 1.0 m
- 015 1.5 m
- 020 2.0 m
- 050 5.0 m
- 075 7.5 m
- 100 10.0 m

\* Other cable lengths on request!

Cable

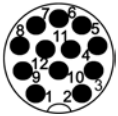

Male, 12 poles

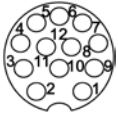

Female, 12 poles



## Technical characteristics

System cables with M12 circular connectors without PE, A-coding

	12 poles	
	PVC	PUR
Rated voltage	max. 30 V AC/DC	max. 30 V AC/DC
Rated current / contact	max. 1.5 A @ +40 °C	max. 1.5 A @ +40 °C
Screw locking	M12x1, self securing	M12x1, self securing
Recommended torque	0.6 Nm	0.6 Nm
Temperature range (working and storage)	-30 °C ... +80 °C	-30 °C ... +80 °C
Degree of protection	IP67	IP67
Number of wires / wire gauge	12 x 0.14 mm <sup>2</sup>	12 x 0.14 mm <sup>2</sup>
Conductor insulation	PVC (wh, bu, bn, gy, rd, bk, ye, pk, gn, vt, rd/bu, gy/pk)	PP (wh, bu, bn, gy, rd, bk, ye, pk, gn, vt, rd/bu, gy/pk)
Arrangement of insulated strands	18 x Ø 0.1 mm	18 x Ø 0.1 mm
Sheath	PVC	PUR (UL, CSA)
Sheath colour	grey	black
Outer diameter	Ø 6.2 ± 0.2 mm	Ø 6.1 ± 0.2 mm
Useable as trailing cable	no	yes
Halogen free acc. to	-	DIN VDE 0472 part 815
Flame retardant acc. to	DIN EN 60332-1-2	cUL20549
Oil-resistant	DIN EN 60811-2-1	-

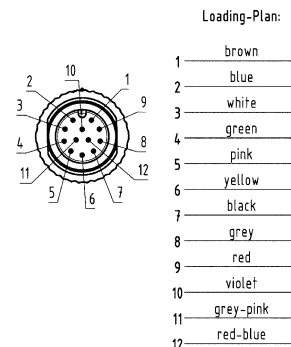

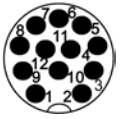

Male, 12 poles

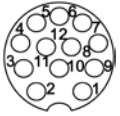

Female, 12 poles



Cable

## Part number definition

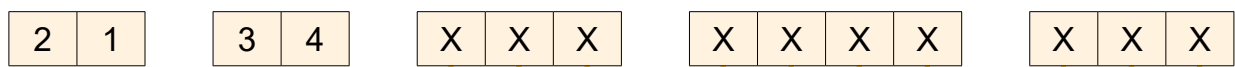

### Connector 1

- 84 Male straight
- 85 Female straight
- 86 Male angled
- 87 Female angled

### Connector 2

- 00 No connector
- 84 Male straight
- 85 Female straight
- 86 Male angled
- 87 Female angled

### Number of contacts

C 12 poles

### Cable material

- 78 PUR
- 79 PVC

### Preferred length\*

- 005 0.5 m
- 010 1.0 m
- 015 1.5 m
- 020 2.0 m
- 050 5.0 m
- 075 7.5 m
- 100 10.0 m

\* Other cable lengths on request!

Cable



Male, 4 poles

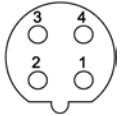

Female, 4 poles



## Technical characteristics

System cables with M12 circular connectors shielded, B-coding

	4 poles	
	PVC	PUR
Rated voltage	max. 160 V AC/DC	max. 160 V AC/DC
Rated current / contact	max. 4 A @ +40 °C	max. 4 A @ +40 °C
Screw locking	M12x1, self securing	M12x1, self securing
Recommended torque	0.6 Nm	0.6 Nm
Temperature range (working and storage)	-30 °C ... +80 °C	-30 °C ... +80 °C
Degree of protection	IP67	IP67
Number of wires / wire gauge	2 x AWG 22	2 x AWG 24
Conductor insulation	PVC (rd, gn)	PE (rd, gn)
Arrangement of insulated strands	1 x Ø 0.65 mm	19 x Ø 0.14 mm
Sheath	PVC	PUR (UL, CSA)
Sheath colour	violet	violet
Outer diameter	Ø 8.0 ± 0.4 mm	Ø 8.5 ± 0.4 mm
Useable as trailing cable	no	yes
Halogen free acc. to	-	DIN VDE 0472 part 815
Flame retardant acc. to	DIN EN 60332-1-2	DIN EN 60332-1-2
Oil-resistant	IEC 80811-2-1 (4h/60°C)	DIN EN 60811-2-1

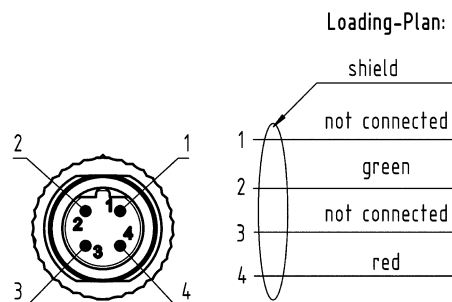



Male, 4 poles

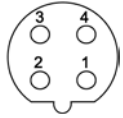

Female, 4 poles



Cable

## Part number definition



### Connector 1

- 88 Male straight
- 89 Female straight
- 90 Male angled
- 91 Female angled

### Connector 2

- 00 No connector
- 88 Male straight
- 89 Female straight
- 90 Male angled
- 91 Female angled

### Number of contacts

4 4 poles

### Cable material

- 86 PVC
- 87 PUR

### Preferred length\*

- 005 0.5 m
- 010 1.0 m
- 015 1.5 m
- 020 2.0 m
- 050 5.0 m
- 075 7.5 m
- 100 10.0 m

\* Other cable lengths on request!

Cable

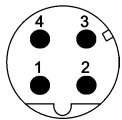

Male, 4 poles

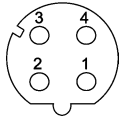

Female, 4 poles



## Technical characteristics

System cables with M12 circular connectors shielded, D-coding

	4 poles	
	PVC	PUR
Rated voltage	max. 160 V AC/DC	max. 160 V AC/DC
Rated current / contact	max. 4 A @ +40 °C	max. 4 A @ +40 °C
Screw locking	M12x1, self securing	M12x1, self securing
Recommended torque	0.6 Nm	0.6 Nm
Temperature range (working and storage)	-30 °C ... +80 °C	-30 °C ... +80 °C
Degree of protection	IP67	IP67
Number of wires / wire gauge	4 x AWG 22	4 x AWG 22
Conductor insulation	PE (ye, wh, og, bu)	PE (ye, wh, og, bu)
Arrangement of insulated strands	7 x Ø 0.25 mm (AWG 22)	7 x Ø 0.25 mm (AWG 22)
Sheath	PVC	PUR (UL, CSA)
Sheath colour	green	green
Outer diameter	Ø 6.5 ± 0.2 mm	Ø 6.5 ± 0.2 mm
Useable as trailing cable	no	yes
Halogen free acc. to	–	IEC 60754
Flame retardant acc. to	UL 1685 (CSA FT4)	IEC 60332-1-2 und UL 2556 VW1
Oil-resistant	IEC 80811-2-1 (4h/70°C)	IEC 60811-2-1 und UL13

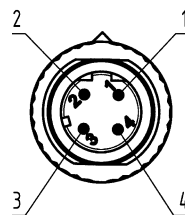

Loading-Plan:

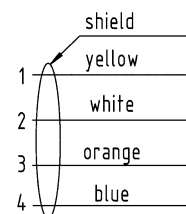

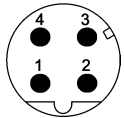

Male, 4 poles

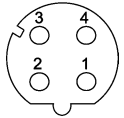

Female, 4 poles



Cable

## Part number definition



### Connector 1

- 92 Male straight
- 93 Female straight
- 94 Male angled
- 95 Female angled

### Connector 2

- 00 No connector
- 92 Male straight
- 93 Female straight
- 94 Male angled
- 95 Female angled

### Number of contacts

4 4 poles

### Cable material

- 05 PVC
- 77 PUR

### Preferred length\*

- 005 0.5 m
- 010 1.0 m
- 015 1.5 m
- 020 2.0 m
- 050 5.0 m
- 075 7.5 m
- 100 10.0 m

\* Other cable lengths on request!

Cable



**HARTING M12**  
system cable, 4-wire, straight resp. angled

## Features

- Connector types M12 D-coding, connector straight resp. angled
- Category Cat. 5
- Number of wires 4
- Wiring 1:1
- Sheath material Elastomer, electron beam cross-linked

## Application

- For harsh industrial environments
- For installation in railway applications

## Benefits

- Robust design
- Protection degree IP65/IP67
- Fire protection acc. to EN 45545-1, -2 and -5

## Technical characteristics

- Connector types HARTING M12 D-coding, overmoulded
- Railway cords type 4 x AWG 22/7, stranded
- Sheath material Elastomer, electron beam cross-linked
- Wiring 4 pole, 1:1
- Transmission performance Class D up to 100 MHz acc. to ISO/IEC 11801, EN 50173-1
- Transmission rate 10/100 Mbit/s
- Shielding Fully shielded, 360° shielding contact
- Operating temperature range fix operation -40 °C ... +85 °C
- Colour Black or blue



## HARTING M12 system cable, 4-wire, straight resp. angled

Identification	Part number	Drawing	Dimensions in mm
<b>HARTING</b> M12 system cable, 4-wire, straight one side assembled	<b>Black</b>		
	Length		
	0.5 m	09 48 220 0011 005	
	1.0 m	09 48 220 0011 010	
	2.0 m	09 48 220 0011 020	
	2.5 m	09 48 220 0011 025	
	5.0 m	09 48 220 0011 050	
	7.5 m	09 48 220 0011 075	
	10.0 m	09 48 220 0011 100	
	15.0 m	09 48 220 0011 150	
	20.0 m	09 48 220 0011 200	
	<b>Blue</b>		
	Length		
	0.5 m	21 33 390 0413 005	
	1.0 m	21 33 390 0413 010	
	2.0 m	21 33 390 0413 020	
	2.5 m	21 33 390 0413 025	
	5.0 m	21 33 390 0413 050	
	7.5 m	21 33 390 0413 075	
	10.0 m	21 33 390 0413 100	
15.0 m	21 33 390 0413 150		
20.0 m	21 33 390 0413 200		
both sides assembled	<b>Black</b>		
	Length		
	0.5 m	09 48 222 2011 005	
	1.0 m	09 48 222 2011 010	
	2.0 m	09 48 222 2011 020	
	2.5 m	09 48 222 2011 025	
	5.0 m	09 48 222 2011 050	
	7.5 m	09 48 222 2011 075	
	10.0 m	09 48 222 2011 100	
	15.0 m	09 48 222 2011 150	
20.0 m	09 48 222 2011 200		

Other cable lengths on request!

Cable



## HARTING M12 system cable, 4-wire, straight resp. angled

Identification	Part number	Drawing	Dimensions in mm
<b>HARTING</b> <b>M12 system cable,</b> <b>4-wire, angled</b> one side assembled	Black		
Length			
0.5 m	09 48 800 0011 005		
1.0 m	09 48 800 0011 010		
2.0 m	09 48 800 0011 020		
2.5 m	09 48 800 0011 025		
5.0 m	09 48 800 0011 050		
7.5 m	09 48 800 0011 075		
10.0 m	09 48 800 0011 100		
15.0 m	09 48 800 0011 150		
20.0 m	09 48 800 0011 200		
both sides assembled	Black		
Length			
0.5 m	09 48 808 0011 005		
1.0 m	09 48 808 0011 010		
2.0 m	09 48 808 0011 020		
2.5 m	09 48 808 0011 025		
5.0 m	09 48 808 0011 050		
7.5 m	09 48 808 0011 075		
10.0 m	09 48 808 0011 100		
15.0 m	09 48 808 0011 150		
20.0 m	09 48 808 0011 200		

CAB  
03  
-  
18

Other cable lengths on request!



**HARTING M12/RJ45**  
system cable, 4-wire, straight

Identification	Part number	Drawing	Dimensions in mm
<p><b>HARTING</b> M12/RJ45 system cable, 4-wire</p> <p>both sides assembled</p>	<p><b>Black</b></p>	<p>Mating face RJ45 acc. to IEC 60603-7</p> <p>HARTING RJ Industrial RJ45, Cat. 5, 4-wire, overmolded Protection Level: IP20</p> <p>M12 D-Coded straight, overmolded male Protection Level: IP67</p> <p>Mating face acc. to IEC 61076-2-101</p> <p>Shield</p> <p>1 yellow</p> <p>2 orange</p> <p>3 white</p> <p>4 blue</p>	<p>Length 1.0 m 09 48 022 2011 010</p> <p>1.5 m 09 48 022 2011 015</p> <p>2.0 m 09 48 022 2011 020</p> <p>3.0 m 09 48 022 2011 030</p> <p>5.0 m 09 48 022 2011 050</p> <p>7.5 m 09 48 022 2011 075</p> <p>10.0 m 09 48 022 2011 100</p> <p>15.0 m 09 48 022 2011 150</p> <p>20.0 m 09 48 022 2011 200</p>

Other cable lengths on request!





Cable



Press & Go M12  
system cable, 8-wire, Cat. 6<sub>A</sub>

## Features

- Connector types M12 X-coding
- Category Cat. 6<sub>A</sub>
- Number of wires 8
- Wiring 1:1
- Sheath material PVC/PUR

## Application

- Industrial cabling IP65/IP67
- Transmission up to 10 Gbit/s
- Camera systems

## Benefits

- Very robust metal housing M12 with degree of protection IP65/IP67
- Vibration proof crimp connection
- Maximum data rates through the configuration of the contacts in conformance with Ethernet technology
- Minimal interaction and perfect shielding through paired shielding of the contacts
- Fault proof connection through coding of the connector face. A connection error with other 8 pole M12's is impossible
- PROFINET compliant Type X mating face
- Oil proof acc. to EN 60811-2-1 (PUR)

## Technical characteristics

- Connector types Press & Go M12 connector X coding acc. to IEC 61076-2-109
- Cable types
  - PVC: 4 x 2 x AWG 26/7, cat. 6<sub>A</sub>, S/FTP, shielded
  - PUR: 4 x 2 x AWG 26/7, cat. 7, S/FTP, shielded
- Sheath material PVC/PUR
- Wiring 8 pole, 1:1
- Transmission performance Category 6<sub>A</sub>, Class E<sub>A</sub> up to 500 MHz acc. to ISO/IEC 11801, EN 50173-1
- Transmission rate 10/100 Mbit/s  
1/ 10 Gbit/s
- Shielding Fully shielded, 360° shielding contact
- Operating temperature range -40 °C ... +70 °C
- Colour Yellow



Cable

Press & Go M12  
system cable, 8-wire, Cat. 6A

Identification	Part number	
	PUR	PVC
Press & Go M12 system cable, 8-wire one side assembled		
Length 1.0 m	21 33 050 0850 010	21 33 050 0855 010
2.0 m	21 33 050 0850 020	21 33 050 0855 020
3.0 m	21 33 050 0850 030	21 33 050 0855 030
5.0 m	21 33 050 0850 050	21 33 050 0855 050
10.0 m	21 33 050 0850 100	21 33 050 0855 100
both sides assembled		
Length 1.0 m	21 33 050 5850 010	21 33 050 5855 010
2.0 m	21 33 050 5850 020	21 33 050 5855 020
3.0 m	21 33 050 5850 030	21 33 050 5855 030
5.0 m	21 33 050 5850 050	21 33 050 5855 050
10.0 m	21 33 050 5850 100	21 33 050 5855 100

Other cable lengths on request!

Cable

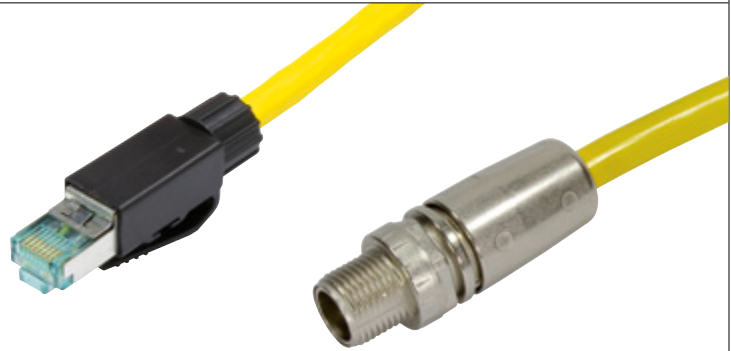

M12/RJ45  
system cable, 8-wire, Cat. 6<sub>A</sub>

## Features

- Connector types M12 X-coding to RJ45
- Category Cat. 6<sub>A</sub>
- Number of wires 8
- Wiring 1:1
- Sheath material PVC/PUR

## Application

- Industrial cabling IP65/IP67
- Transmission up to 10 Gbit/s
- Camera systems

## Benefits

- Very robust metal housing M12 with degree of protection IP65
- Vibration proof crimp connection
- Maximum data rates through the configuration of the contacts in conformance with Ethernet technology
- Minimal interaction and perfect shielding through paired shielding of the contacts
- Fault proof connection through coding of the connector face. A connection error with other 8 pole M12's is impossible
- PROFINET compliant Type X mating face

## Technical characteristics

- Connector types *har*-speed M12 connector X coding acc. to IEC 61076-2-109 and RJ45 Gigalink
- Cable types 4 x 2 x AWG 26/7, cat. 6<sub>A</sub>, S/FTP, shielded
- Sheath material PVC/PUR
- Wiring 8 pole, 1:1
- Transmission performance Category 6<sub>A</sub>, Class E<sub>A</sub> up to 500 MHz acc. to ISO/IEC 11801, EN 50173-1
- Transmission rate 10/100 Mbit/s  
1/ 10 Gbit/s
- Shielding Fully shielded, 360° shielding contact
- Operating temperature range -40 °C ... +70 °C
- Colour Yellow

Identification	Part number	
	PUR	PVC
M12/RJ45 system cable, 8-wire	Yellow	Yellow
Length 0.5 m	09 48 932 3756 005	09 48 932 3757 005
1.0 m	09 48 932 3756 010	09 48 932 3757 010
1.5 m	09 48 932 3756 015	09 48 932 3757 015
2.0 m	09 48 932 3756 020	09 48 932 3757 020
2.5 m	09 48 932 3756 025	09 48 932 3757 025
5.0 m	09 48 932 3756 050	09 48 932 3757 050
7.5 m	09 48 932 3756 075	09 48 932 3757 075
10.0 m	09 48 932 3756 100	09 48 932 3757 100

Other cable lengths on request!

X-coding



Female, 8 poles

*har-speed* M12  
Panel feed-throughs with cable



Cable

Identification

Part number

Drawing

Dimensions in mm

*har-speed* M12 PFT with cable

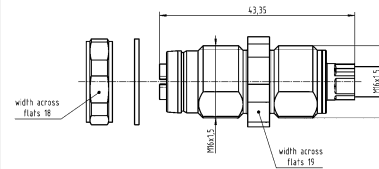

with 0.3 m cable  
“Cat. 7<sub>A</sub> (2 x AWG 27/7) PIMF”.  
Other lengths on request

21 33 080 0850 003

with 0.3 m cable  
“HA-VIS EtherRail Cat. 7 4 x (2 x AWG 24/7)”.  
Other lengths on request

21 33 070 0853 003



**HARTING M12**  
system cable, 8-wire, straight

## Features

- Connector type M12 X-coding
- Category 6<sub>A</sub>
- Number of wires 8
- Wire design AWG 24/7
- Wire diameter (8.1 ± 0.4) mm
- Sheath material Elastomer, electron beam cross-linked

## Application

- For harsh industrial environments
- For installation in railway applications

## Benefits

- Transmission of Gigabit and 10 Gigabit Ethernet acc. IEEE 802.3 and multimedia services
- Fire protection acc. EN 45545-1, -2 and -5, flame retardant and heat resistant acc. DIN 5510 (1-4) and EN 50264-1
- UV resistant, RoHS conform, halogen free LSZH

## Technical characteristics

- Connector types HARTING M12 X-coding
- Cable structure 4 x 2, Twisted Pair, shielded, PIMF
- Railway cords type 4 x 2 x AWG 24/7  
Category 7, Class F  
up to 600 MHz  
acc. to ISO/IEC 11801  
and EN 50 173-1
- Sheath material Elastomer, electron beam, cross-linked
- Cable sheath diameter (8.1 ± 0.4) mm
- Transmission performance Category 6<sub>A</sub>, Class E<sub>A</sub>  
up to 500 MHz  
acc. to ISO/IEC 11801  
and EN 50 173-1
- Transmission rate 1/10 Gbit/s
- Shielding Paired shielded with additional cable shield
- Operating temperature range -40 °C ... +80 °C
- Colour Black



## HARTING M12 system cable, 8-wire, straight

Identification	Part number	Drawing	Dimensions in mm
<p><b>HARTING M12 system cable, 8-wire, Slim Design</b> both sides assembled</p> <p>Length 0.5 m 1.0 m 2.0 m 2.5 m 5.0 m 7.5 m 10.0 m 15.0 m 20.0 m</p>	<p><b>Black</b></p> <p>21 33 010 1853 005 21 33 010 1853 010 21 33 010 1853 020 21 33 010 1853 025 21 33 010 1853 050 21 33 010 1853 075 21 33 010 1853 100 21 33 010 1853 150 21 33 010 1853 200</p>		
<p><b>HARTING M12 system cable, 8-wire, Press &amp; Go</b> one side assembled</p> <p>Length 0.5 m 1.0 m 2.0 m 2.5 m 5.0 m 7.5 m 10.0 m 15.0 m 20.0 m</p>	<p><b>Black</b></p> <p>21 33 050 0853 005 21 33 050 0853 010 21 33 050 0853 020 21 33 050 0853 025 21 33 050 0853 050 21 33 050 0853 075 21 33 050 0853 100 21 33 050 0853 150 21 33 050 0853 200</p>		
<p><b>both sides assembled</b></p> <p>Length 0.5 m 1.0 m 2.0 m 2.5 m 5.0 m 7.5 m 10.0 m 15.0 m 20.0 m</p>	<p><b>Black</b></p> <p>21 33 050 5853 005 21 33 050 5853 010 21 33 050 5853 020 21 33 050 5853 025 21 33 050 5853 050 21 33 050 5853 075 21 33 050 5853 100 21 33 050 5853 150 21 33 050 5853 200</p>		

Other cable lengths on request!



**HARTING M12**  
system cable, 8-wire, straight, PushPull Press & Go

## Features

- Connector type M12 X-coding PushPull
- Category 6<sub>A</sub>
- Number of wires 8
- Wire design AWG 24/7
- Wire diameter (8.1 ± 0.4) mm
- Sheath material Elastomer, electron beam cross-linked

## Application

- For harsh industrial environments
- For installation in railway applications

## Benefits

- Transmission of Gigabit and 10 Gigabit Ethernet acc. IEEE 802.3 and multimedia services
- Fire protection acc. EN 45545-1, -2 and -5, flame retardant and heat resistant acc. DIN 5510 (1-4) and EN 50264-1
- UV resistant, RoHS conform, halogen free LSZH
- M12 PushPull for a fast and vibration-free connection

## Technical characteristics

- Connector types HARTING M12 X-coding PushPull
- Cable structure 4 x 2, Twisted Pair, shielded, PIMF
- Railway cords type 4 x 2 x AWG 24/7  
Category 7, Class F  
up to 600 MHz  
acc. to ISO/IEC 11801  
and EN 50 173-1
- Sheath material Elastomer, electron beam, cross-linked
- Cable sheath diameter (8.1 ± 0.4) mm
- Transmission performance Category 6<sub>A</sub>, Class E<sub>A</sub>  
up to 500 MHz  
acc. to ISO/IEC 11801  
and EN 50 173-1
- Transmission rate 1/10 Gbit/s
- Shielding Paired shielded with additional cable shield
- Operating temperature range -40 °C ... +80 °C
- Colour Black



## HARTING M12 system cable, 8-wire, straight, PushPull Press & Go

Identification	Part number PVC	Drawing	Dimensions in mm
<b>HARTING M12 system cable, 8-wire, PushPull Press &amp; Go</b> one side assembled	<b>Black</b>		
Length 0.5 m	21 33 290 0853 005		
1.0 m	21 33 290 0853 010		
2.0 m	21 33 290 0853 020		
2.5 m	21 33 290 0853 025		
5.0 m	21 33 290 0853 050		
7.5 m	21 33 290 0853 075		
10.0 m	21 33 290 0853 100		
15.0 m	21 33 290 0853 150		
20.0 m	21 33 290 0853 200		
<b>both sides assembled</b>	<b>Black</b>		
Length 0.5 m	21 33 292 9853 005		
1.0 m	21 33 292 9853 010		
2.0 m	21 33 292 9853 020		
2.5 m	21 33 292 9853 025		
5.0 m	21 33 292 9853 050		
7.5 m	21 33 292 9853 075		
10.0 m	21 33 292 9853 100		
15.0 m	21 33 292 9853 150		
20.0 m	21 33 292 9853 200		

Other cable lengths on request!

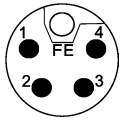

Male, 4 + FE

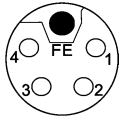

Female, 4 + FE



## Technical characteristics

### System cables with M12 circular connectors with FE, L-coding

	5 poles	5 poles	5 poles	5 poles
	PVC	PVC	PVC shielded	PVC shielded
Rated voltage	max. 63 V AC/DC	max. 63 V AC/DC	max. 63 V AC/DC	max. 63 V AC/DC
Rated current / contact	max. 16 A	max. 16 A	max. 16 A	max. 16 A
Screw locking	M12x1, self securing	M12x1, self securing	M12x1, self securing	M12x1, self securing
Recommended torque	0.6 Nm	0.6 Nm	0.6 Nm	0.6 Nm
Temperature range connector (working and storage)	-5 °C ... +50 °C	-5 °C ... +50 °C	-5 °C ... +50 °C	-5 °C ... +50 °C
Degree of protection	IP67	IP67	IP67	IP67
Number of wires / wire gauge	5 x 1.5 mm <sup>2</sup>	5 x 2.5 mm <sup>2</sup>	5 x 1.5 mm <sup>2</sup>	5 x 2.5 mm <sup>2</sup>
Conductor insulation	PVC	PVC	PVC	PVC
Sheath	PVC	PVC	PVC	PVC
Sheath colour	grey	grey	grey	grey
Outer diameter	Ø 8.3 mm	Ø 10.1 mm	Ø 9.2 mm	Ø 11.0 mm
Temperature range cable (flexible / fixed)	-15 °C ... +80 °C -40 °C ... +80 °C	-15 °C ... +80 °C -40 °C ... +80 °C	-10 °C ... +80 °C -40 °C ... +80 °C	-10 °C ... +80 °C -40 °C ... +80 °C
Useable as trailing cable	no	no	no	no
Halogen free acc. to	no	no	no	no
Flame retardant acc. to	IEC 60332-1-2	IEC 60332-1-2	IEC 60332-1-2	IEC 60332-1-2
Oil-resistant	yes	yes	yes	yes

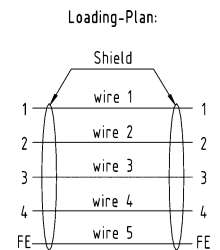
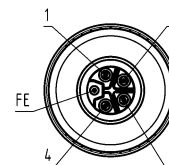
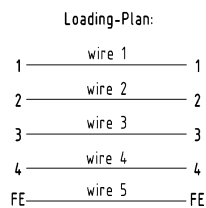
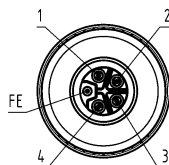

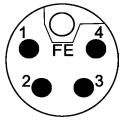

Male, 4 + FE

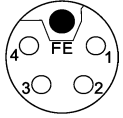

Female, 4 + FE



Cable

## Part number definition



### Connector 1

- A8 Male straight
- A7 Female straight

### Connector 2

- 00 No connector
- A8 Male straight
- A7 Female straight

### Number of contacts

- 5 4 + FE

### Cable material

- 18 PVC shielded (5 x 1.5 mm<sup>2</sup>)
- 19 PVC shielded (5 x 2.5 mm<sup>2</sup>)
- 23 PVC (5 x 1.5 mm<sup>2</sup>)
- 24 PVC (5 x 2.5 mm<sup>2</sup>)

### Preferred length\*

- 005 0.5 m
- 010 1.0 m
- 015 1.5 m
- 020 2.0 m
- 050 5.0 m
- 075 7.5 m
- 100 10.0 m

\* Other cable lengths on request!

Cable

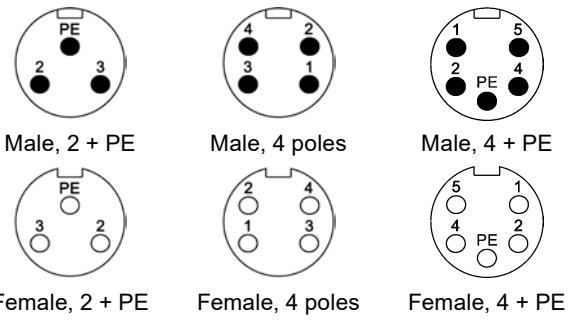

## Technical characteristics

### 7/8" system cables

	3 poles (2+PE)		4 poles		5 poles (4+PE)	
	PVC	PUR	PVC	PUR	PVC	PUR
Rated voltage	max. 300 V AC/DC	max. 300 V AC/DC	max. 300 V AC/DC	max. 300 V AC/DC	max. 300 V AC/DC	max. 300 V AC/DC
Rated current / contact	max. 10 A @ +40 °C	max. 10 A @ +40 °C	max. 10 A @ +40 °C	max. 10 A @ +40 °C	max. 10 A @ +40 °C	max. 10 A @ +40 °C
Screw locking	7/8", self securing	7/8", self securing	7/8", self securing	7/8", self securing	7/8", self securing	7/8", self securing
Temperature range (working and storage)	-30 °C ... +80 °C	-30 °C ... +80 °C	-30 °C ... +80 °C	-30 °C ... +80 °C	-30 °C ... +80 °C	-30 °C ... +80 °C
Degree of protection	IP67	IP67	IP67	IP67	IP67	IP67
Number of wires / wire gauge	3 x 1.5 mm <sup>2</sup>	3 x 1.5 mm <sup>2</sup>	4 x 1.5 mm <sup>2</sup>	4 x 1.5 mm <sup>2</sup>	5 x 1.5 mm <sup>2</sup>	5 x 1.5 mm <sup>2</sup>
Conductor insulation	PVC (bn, bu, gn/ye)	PP (bn, bu, gn/ye)	PVC (bn, wh, bu, bk)	PP (bn, wh, bu, bk)	PVC (bu, bk, wh, bn, gn/ye)	PP (bu, bk, wh, bn, gn/ye)
Arrangement of insulated strands	84 x Ø 0.15 mm	84 x Ø 0.15 mm	84 x Ø 0.15 mm	84 x Ø 0.15 mm	84 x Ø 0.15 mm	84 x Ø 0.15 mm
Sheath	PVC	PUR (UL, CSA)	PVC	PUR (UL, CSA)	PVC	PUR (UL, CSA)
Sheath colour	grey	black	grey	black	grey	black
Outer diameter	Ø 7.0 ± 0.2 mm	Ø 7.0 ± 0.2 mm	Ø 7.8 ± 0.2 mm	Ø 7.1 ± 0.2 mm	Ø 8.5 ± 0.2 mm	Ø 7.8 ± 0.2 mm
Useable as trailing cable	no	yes	no	yes	no	yes
Halogen free acc. to	–	DIN VDE 0472 part 815	–	DIN VDE 0472 part 815	–	DIN VDE 0472 part 815
Flame retardant acc. to	DIN EN 60332-1-2	DIN EN 60332-1-2	DIN EN 60332-1-2	cUL20549	DIN EN 60332-1-2	cUL20549
Oil-resistant	IEC 60811-2-1	DIN EN 60811-2-1	–	–	–	–
	<p>Loading-Plan: PE—green-yellow 2—brown 3—blue</p>	<p>Loading-Plan: 1—brown 2—white 3—blue 4—black</p>	<p>Loading-Plan: 1—black 2—blue PE—green-yellow 4—brown 5—white</p>			

CAB  
03  
-  
32

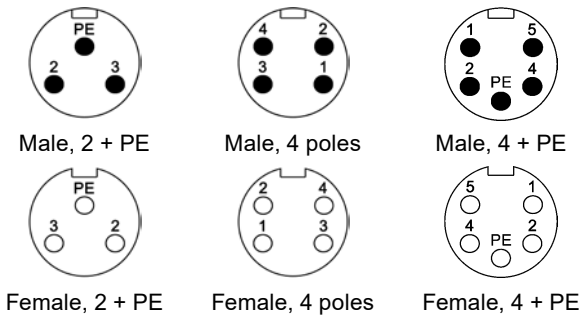

Cable

## Part number definition



- Connector 1**
- 96 Male straight
  - 97 Female straight
  - 98 Male angled
  - 99 Female angled

- Connector 2**
- 00 No connector
  - 96 Male straight
  - 97 Female straight
  - 98 Male angled
  - 99 Female angled

- Number of contacts**
- 3 2 + PE
  - 4 4 poles
  - 5 4 + PE

- Cable material**
- 93 PVC (2 + PE)
  - 94 PUR (2 + PE)
  - 95 PVC (4 poles)
  - 96 PUR (4 poles)
  - 97 PVC (4 + PE)
  - 98 PUR (4 + PE)

- Preferred length\***
- 005 0.5 m
  - 010 1.0 m
  - 015 1.5 m
  - 020 2.0 m
  - 050 5.0 m
  - 075 7.5 m
  - 100 10.0 m

\* Other cable lengths on request!

Cable

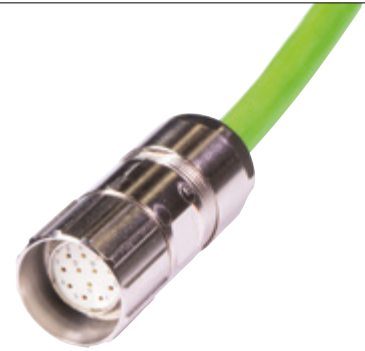

M23 signal  
encoder cable, straight, screw, ComLock, ComLock-S

## Features

- Connector type M23 signal  
D-Sub male, angled
- Locking type Screw  
ComLock  
ComLock-S
- Number of contacts M23: 12  
D-Sub: 9
- Degree of protection IP65 / IP67 when mated

## Application

- For harsh industrial environments
- For servo drives
- Standard in acc. to Lenze

## Benefits

- 360° shielding
- Cables suitable for industry
- Drag chain compatible
- Fast lock technology ComLock-S compatible with Speedtec locking
- EMC conform

## Technical characteristics

Cable structure	Copper conductor in acc. to DIN VDE 0295 cl. 6 Fine wire BS 6360 cl. 6 IEC 60228 cl. 6
Core structure	3 x (2 x 0.14) mm <sup>2</sup> + (2 x 0.5) mm <sup>2</sup>
Sheath material	PUR
Cable sheath diameter	9.8 mm
Shielding	4 shielded pairs
Temperature range moved fixed	-30 °C ... +80 °C -40 °C ... +80 °C
Bending radius moved fixed	10 x cable diameter 6 x cable diameter
Colour	Black
System	Lenze



## M23 signal encoder cable, straight, screw, ComLock, ComLock-S

Identification	Part number	Drawing	Dimensions in mm																																																				
Encoder cable, M23, 12 pole, straight, female to D-Sub, 9 pole, angled, male Screw																																																							
Length 5.0 m	09 48 A06 0847 050	<p>M23 Signal, straight, 12-pole, Screw</p>																																																					
7.5 m	09 48 A06 0847 075																																																						
10.0 m	09 48 A06 0847 100																																																						
15.0 m	09 48 A06 0847 150																																																						
ComLock (fast locking hood for M23 signal)																																																							
Length 5.0 m	09 48 A16 0847 050	<p>M23 Signal, straight, 12-pole, ComLock</p>																																																					
7.5 m	09 48 A16 0847 075																																																						
10.0 m	09 48 A16 0847 100																																																						
15.0 m	09 48 A16 0847 150																																																						
ComLock-S (fast locking hood for Speedtec products)																																																							
Length 5.0 m	09 48 A26 0847 050	<p>M23 Signal, straight, 12-pole, ComLock-S</p>																																																					
7.5 m	09 48 A26 0847 075																																																						
10.0 m	09 48 A26 0847 100																																																						
15.0 m	09 48 A26 0847 150																																																						
		<table border="1"> <thead> <tr> <th>Pin Conn. Loc. A</th> <th>Wire</th> <th>Signal</th> <th>Pin Conn. Loc. B</th> </tr> </thead> <tbody> <tr> <td>1</td> <td>yellow</td> <td rowspan="2">pair</td> <td>+Ref 1</td> </tr> <tr> <td>2</td> <td>green</td> <td>-Ref 2</td> </tr> <tr> <td>3</td> <td>n.c.</td> <td></td> <td>+VCC ETS 3</td> </tr> <tr> <td>4</td> <td>grey</td> <td rowspan="2">pair</td> <td>+COS 4</td> </tr> <tr> <td>5</td> <td>pink</td> <td>-COS 5</td> </tr> <tr> <td>6</td> <td>red</td> <td rowspan="2">pair</td> <td>+SIN 6</td> </tr> <tr> <td>7</td> <td>blue</td> <td>-SIN 7</td> </tr> <tr> <td>8</td> <td></td> <td></td> <td></td> </tr> <tr> <td>9</td> <td></td> <td></td> <td></td> </tr> <tr> <td>10</td> <td></td> <td>n.c.</td> <td></td> </tr> <tr> <td>11</td> <td>white</td> <td rowspan="2">pair</td> <td>+KTY 8</td> </tr> <tr> <td>12</td> <td>brown</td> <td>-KTY 9</td> </tr> <tr> <td>Shield</td> <td>Shield</td> <td></td> <td>Shield</td> </tr> </tbody> </table>	Pin Conn. Loc. A	Wire	Signal	Pin Conn. Loc. B	1	yellow	pair	+Ref 1	2	green	-Ref 2	3	n.c.		+VCC ETS 3	4	grey	pair	+COS 4	5	pink	-COS 5	6	red	pair	+SIN 6	7	blue	-SIN 7	8				9				10		n.c.		11	white	pair	+KTY 8	12	brown	-KTY 9	Shield	Shield		Shield	
Pin Conn. Loc. A	Wire	Signal	Pin Conn. Loc. B																																																				
1	yellow	pair	+Ref 1																																																				
2	green		-Ref 2																																																				
3	n.c.		+VCC ETS 3																																																				
4	grey	pair	+COS 4																																																				
5	pink		-COS 5																																																				
6	red	pair	+SIN 6																																																				
7	blue		-SIN 7																																																				
8																																																							
9																																																							
10		n.c.																																																					
11	white	pair	+KTY 8																																																				
12	brown		-KTY 9																																																				
Shield	Shield		Shield																																																				

Other cable lengths on request!



M23 power  
motor cable, straight, screw, ComLock, ComLock-S

## Features

- Connector type M23 power
- Locking type Screw  
ComLock  
ComLock-S
- Number of contacts 5 + PE
- Degree of protection IP65 / IP67 when mated

## Application

- For harsh industrial environments
- For servo drives
- Standard in acc. to Lenze

## Benefits

- 360° shielding
- Cables suitable for industry
- Drag chain compatible
- Fast lock technology ComLock-S compatible with Speedtec locking
- EMC conform

## Technical characteristics

Cable structure	Copper conductor in acc. to DIN VDE 0295 cl. 6 Fine wire IEC 60228 cl. 6
Core structure	(4 x 1.5 + (2 x 0.5)) mm <sup>2</sup>
Sheath material	PUR
Cable sheath diameter	11.5 mm
Shielding	Shielded pair for the control unit and additional overall cable shielding
Temperature range	
moved	-30 °C ... +80 °C
fixed	-40 °C ... +90 °C
Bending radius	
moved	7.5 x cable diameter
fixed	6 x cable diameter
Colour	Orange
System	Lenze



## M23 power motor cable, straight, screw, ComLock, ComLock-S

Identification	Part number	Drawing	Dimensions in mm																																								
<p>Motor cable, M23, 5 + PE, straight, female</p> <p>Screw</p> <p>Length 5.0 m 7.5 m 10.0 m 15.0 m</p>	<p>21 37 010 0637 050 21 37 010 0637 075 21 37 010 0637 100 21 37 010 0637 150</p>																																										
<p>ComLock (fast locking hood for M23 signal)</p> <p>Length 5.0 m 7.5 m 10.0 m 15.0 m</p>	<p>21 37 020 0637 050 21 37 020 0637 075 21 37 020 0637 100 21 37 020 0637 150</p>																																										
<p>ComLock-S (fast locking hood for Speedtec products)</p> <p>Length 5.0 m 7.5 m 10.0 m 15.0 m</p>	<p>21 37 030 0637 050 21 37 030 0637 075 21 37 030 0637 100 21 37 030 0637 150</p>																																										
			<table border="1"> <thead> <tr> <th>Pin Conn. Loc. A</th> <th>Wire</th> <th>Signal</th> <th>Length b [m]</th> <th>Pin Conn. Loc. B</th> </tr> </thead> <tbody> <tr> <td>1</td> <td>white</td> <td>BD1+</td> <td>0.2</td> <td>Terminal DIN 46228-4 0.5mm<sup>2</sup></td> </tr> <tr> <td>2</td> <td>brown</td> <td>BD-</td> <td>0.2</td> <td>Terminal DIN 46228-4 0.5mm<sup>2</sup></td> </tr> <tr> <td>4</td> <td>1</td> <td>U</td> <td>0.2</td> <td>Terminal DIN 46228-4 1.5mm<sup>2</sup></td> </tr> <tr> <td>5</td> <td>2</td> <td>V</td> <td>0.2</td> <td>Terminal DIN 46228-4 1.5mm<sup>2</sup></td> </tr> <tr> <td>6</td> <td>3</td> <td>W</td> <td>0.2</td> <td>Terminal DIN 46228-4 1.5mm<sup>2</sup></td> </tr> <tr> <td>PE (3)</td> <td>green/yellow</td> <td>PE</td> <td>0.22</td> <td>Terminal DIN 46228-4 1.5mm<sup>2</sup></td> </tr> <tr> <td>Shield</td> <td>Shield</td> <td></td> <td></td> <td></td> </tr> </tbody> </table>	Pin Conn. Loc. A	Wire	Signal	Length b [m]	Pin Conn. Loc. B	1	white	BD1+	0.2	Terminal DIN 46228-4 0.5mm <sup>2</sup>	2	brown	BD-	0.2	Terminal DIN 46228-4 0.5mm <sup>2</sup>	4	1	U	0.2	Terminal DIN 46228-4 1.5mm <sup>2</sup>	5	2	V	0.2	Terminal DIN 46228-4 1.5mm <sup>2</sup>	6	3	W	0.2	Terminal DIN 46228-4 1.5mm <sup>2</sup>	PE (3)	green/yellow	PE	0.22	Terminal DIN 46228-4 1.5mm <sup>2</sup>	Shield	Shield			
Pin Conn. Loc. A	Wire	Signal	Length b [m]	Pin Conn. Loc. B																																							
1	white	BD1+	0.2	Terminal DIN 46228-4 0.5mm <sup>2</sup>																																							
2	brown	BD-	0.2	Terminal DIN 46228-4 0.5mm <sup>2</sup>																																							
4	1	U	0.2	Terminal DIN 46228-4 1.5mm <sup>2</sup>																																							
5	2	V	0.2	Terminal DIN 46228-4 1.5mm <sup>2</sup>																																							
6	3	W	0.2	Terminal DIN 46228-4 1.5mm <sup>2</sup>																																							
PE (3)	green/yellow	PE	0.22	Terminal DIN 46228-4 1.5mm <sup>2</sup>																																							
Shield	Shield																																										

Other cable lengths on request!



## Contents

## Page

Crimping tool .....

**TOO 03.2**

Assembly tool .....







**TOO 03.6**

Stripping tools.....

**TOO 03.7**

## Technical characteristics





RoHS compliant

Identification	Conductor cross-section (mm <sup>2</sup> )	Part number	
Crimping tool, for turned male and female contact, 4 indent crimp in acc. to MIL 22 520/2-01	0.09 ... 0.82	09 99 000 0501	
Locator, for single D-Sub standard contacts		09 99 000 0531	
Locator, for part number 09 99 000 0501 and Data- und Power contacts Y-coding		09 99 000 0618	
Locator, for <i>har</i> -speed M12 male contacts		09 99 000 0525	
Locator, for <i>har</i> -speed M12 female contacts		09 99 000 0635	
Locator, for M12 male contacts, 21 01 100 9020		61 03 600 0023	
Locator, for M12 female contacts, 21 01 100 9025		09 99 000 0637	

Identification	Conductor cross-section (mm <sup>2</sup> )	Part number	
Crimping tool, for power contacts	0.5 ... 2.5	09 99 000 0509	
Locator, for part number 09 99 000 0509		09 99 000 0638	





Identification	Wrench size	Part number
Crimping tool, for flange Head openable		09 99 000 0647
Crimping insert, for part number 09 99 000 0647	6.5 7 7.5 8 8.5 9 9.5 10	09 99 000 0652 09 99 000 0648 09 99 000 0649 09 99 000 0650 09 99 000 0658 09 99 000 0653 09 99 000 0654 09 99 000 0655



Identification	Conductor cross-section (mm <sup>2</sup> )	Part number	
<p>Circular connectors M23, Crimping tool, for M23 signal contacts, Pack contents: incl. locator, Handling instruction</p>	<p>0.08 ... 2.5</p>	<p>09 99 000 0890</p>	
<p>Circular connectors M23, Crimping tool, for M23 power contacts, for M23 signal contacts, Pack contents: incl. locator, Handling instruction Not to be used for 0.6 mm contacts.</p>	<p>0.14 ... 4</p>	<p>09 99 000 0896</p>	
<p>Circular connectors M23, Crimping tool, for shielded bushing</p>		<p>09 99 000 0898</p>	
<p>Circular connectors M23, Locator, for 0.6 mm data contacts, for crimping tool 09 99 000 0890</p>		<p>09 99 000 0961</p>	

Tools

Identification	Wrench size	Part number	Drawing (dimensions in mm)
Assembly tool, for flange		09 99 000 0639	
Dynamometric screwdriver, for M12 Power	18	09 99 000 0659	
Dynamometric screwdriver, for M8	9 13	09 99 000 0380 09 99 000 0660	
Dynamometric screwdriver, for M12-S	13	09 99 000 0382	
Dynamometric screwdriver, for M12-L	17	09 99 000 0384	
Dynamometric screwdriver, for M12 Slim Design	15	09 99 000 0646	
Dynamometric screwdriver, for 7/8"	22	09 99 000 0395	
Assembly tool, for preLink® terminal module		20 82 000 9901	

Identification	Conductor cross-section (mm <sup>2</sup> )	Part number	
Stripping tool	0.08 ... 10	09 99 000 0159	
Stripping tool, Pack contents: Stripping blade set, Straight	0.03 ... 16	09 99 000 0980	
Stripping blade set, Straight		09 99 000 0981	
Stripping blade set, Oval	10 ... 16	09 99 000 0982	
Stripping blade set, V-shape		09 99 000 0983	

**Armenia:**

refer to Russia

**Australia**

HARTING Pty. Ltd.  
Suite 11 / 2 Enterprise Drive Bundoora  
3083, University Hill Melbourne, Victoria  
Phone 1800 201 081 (toll free calling  
within AUS)  
+61 3 9466 7088  
au@HARTING.com

**Australia and Oceania:**

refer to Australia

**Austria**

HARTING Ges.m.b.H.  
Deutschstraße 19  
1230 Wien  
Phone +43 161 621 21  
at@HARTING.com

**Azerbaijan:**

refer to Turkey

**Baltic States:**

refer to Finland

**Belarus:**

refer to Russia

**Belgium**

HARTING N.V.  
Z.3 Doornveld 23  
1731 Zellik  
Phone +32 2 466 0190  
be@HARTING.com

**Bosnia Herzegovina:**

refer to Austria

**Brazil**

HARTING Ltda.  
Alameda Caiapós, 643  
06460-110- Barueri - São Paulo  
Phone +55 11 5035 0073  
br@HARTING.com

**Canada**

HARTING Canada Inc.  
475 Dumont Avenue  
Suite 300  
Dorval, Quebec, H9S 5W2  
Phone +1 855 659-6653  
info.ca@HARTING.com

**Central America and the Caribbean:**

refer to USA

**Central Asia:**

refer to Russia

**China**

HARTING (Zhuhai) Sales Ltd.  
Room 3501, Grand Gateway I  
No. 1 Hong Qiao Road  
Xu Hui District  
Shanghai 200030  
Phone +86 21 3418 9758  
cn@HARTING.com

**Croatia:**

refer to Austria

**Czech Republic**

HARTING s.r.o.  
Mlýnská 2  
160 00 Praha 6  
Phone +420 220 380 495  
cz@HARTING.com

**Denmark**

HARTING ApS  
Resilience House  
Lysholt Allé 8  
7100 Vejle  
Phone +45 70 25 00 32  
dk@HARTING.com

**Finland**

HARTING Oy  
Teknobulevardi 3-5  
01530 Vantaa  
Phone +358 207 291 510  
fi@HARTING.com

**France**

HARTING France  
ZAC Paris Nord 2  
181 avenue des Nations  
95934 ROISSY CDG  
Phone +33 1 4938 3400  
fr@HARTING.com

**Germany**

HARTING Deutschland  
GmbH & Co. KG  
Simeons carré 1, D-32427 Minden  
Phone +49 571 8896 0  
de@HARTING.com

**Georgia:**

refer to Russia

**Great Britain**

HARTING Limited  
Caswell Road  
Brackmills Industrial Estate  
NN4 7PW GB – Northampton  
Phone +44 1604 82 75 00  
salesuk@HARTING.com

**Greece:**

refer to Italy

**Hong Kong**

HARTING (HK) Limited  
Regional Office Asia Pacific  
3512, Metroplaza Tower 1  
223 Hing Fong Road  
Kwai Fong, N. T.  
Phone +852 2423 7338  
ap@HARTING.com

**Hungary**

HARTING Magyarország Kft.  
Fehérvári út 89-95  
1119 Budapest  
Phone +36 1 205 34 64  
hu@HARTING.com

**India**

HARTING (India) Private Limited  
7th Floor (West Wing)  
Central Square II  
Unit No.B 19 part, B 20 & 21  
TVK Industrial Estate  
Guindy, Chennai 600032  
Phone +91-44-43560415  
in@HARTING.com

**Ireland:**

refer to Great Britain

**Israel:**

refer to Turkey

**Italy**

HARTING S.R.L.  
Via dell' Industria 7  
20090 Vimodrone (MI)  
Phone +39 02 250801  
it@HARTING.com

**Japan**

HARTING K.-K.  
Yusen Shin-Yokohama  
1 Chome Bldg., 2F 1-7-9,  
Shin-Yokohama, Kohoku-ku  
Yokohama 222-0033  
Phone +81 45 476 3456  
jp@HARTING.com

**Korean Republic**

HARTING Korea Co. Ltd.  
B-B108, Woolim Lions Valley 5th  
302 Galmachi-ro, Jungwon-gu  
Seongnam-si, Gyeonggi-do 13201  
Phone +82 31 750 0380  
kr@HARTING.com

**Kosovo:**

refer to Austria

**Macedonia:**

refer to Austria

**Malta:**

refer to Italy

**Mexico**

HARTING Mexico S.A. de C.V.  
IOS Torre Virreyes  
Pedregal No. 24, Co. Molino Del Rey  
Suites 357 A, B, C  
Del Miguel Hidalgo, Mexico D.F. 11600  
Phone +1 800 123 0415  
HARTING.mexico@HARTING.com

**Middle East:**

refer to United Arab Emirates

**Montenegro:**

refer to Austria

**Netherlands**

HARTING B.V.  
Larenweg 44  
5234 's-Hertogenbosch  
Phone +31 736 410 404  
nl@HARTING.com

**Norway**

HARTING A/S  
Østensjøveien 36  
0667 Oslo  
Phone +47 22 700 555  
no@HARTING.com

**Pakistan:**

refer to United Arab Emirates

**Poland**

HARTING Polska Sp. z o.o.  
ul. Duńska 11  
54-427 Wrocław  
Phone +48 71 352 81 71  
pl@HARTING.com

**Romania**

HARTING Romania SCS  
Str. Europa Unita nr 21  
550018 Sibiu  
Phone +40 369 102 610  
ro@HARTING.com

**Russia**

LLC HARTING  
Sverdlovskaya nab., 44, lit. Yu, office 612  
195027, St. Petersburg  
Phone +7 812 327 6477  
ru@HARTING.com

**Serbia:**

refer to Austria

**Singapore**

HARTING Singapore Pte. Ltd.  
25 International Business Park  
#04-108 German Centre  
SGP-Singapore 609916  
Phone +65 6225 5285  
sg@HARTING.com

**Slovakia**

HARTING s.r.o.  
Slovakia branch  
Štefániková Trieda 71, (areál pivovaru)  
949 01 Nitra  
Phone +421 37 655 9089  
sk@HARTING.com

**Slovenia:**

refer to Austria

**South Africa**

HARTING South Africa Proprietary  
Limited  
Ground Floor, Twickenham Building  
The Campus, Cnr Main & Sloane Street  
Bryanston  
Johannesburg (Bryanston)  
2021  
Phone +27 (0) 11 575 0017  
za@HARTING.com

**South America:**

refer to Brazil

**South Asia:**

refer to Singapore

**South Pacific:**

refer to Australia

**Spain**

HARTING Iberia S.A.U.  
C/Viriato, 47 8º Planta  
Edificio Numancia, 1  
08014 Barcelona  
Phone +34 933 638 484  
es@HARTING.com

**Sub-Sahara countries:**

refer to South Africa

**Sweden**

HARTING AB  
Gustavslundsvägen 141B  
167 51 Bromma  
Phone +46 8 445 7171  
se@HARTING.com

**Switzerland**

HARTING AG  
Volketswil branch  
Hofwiesenstrasse 4 A  
8604 Volketswil  
Phone +41 44 908 20 60  
ch@HARTING.com

**Taiwan**

HARTING Taiwan Ltd.  
Room 1, 5/F, 495 GuangFu South Road  
RC-110 Taipei  
Phone +886 227 586 177  
tw@HARTING.com

**Turkey**

HARTING Türkiye Elektronik Ticaret  
Limited Sirketi  
Bayar Cad. Şehit İknur Keleş Sok.  
Dural Plaza No:3 K.11  
34742 Kozyatagi – Istanbul  
Phone +90 216 688 81 00  
tr@HARTING.com

**Ukraine:**

refer to Poland

**United Arab Emirates**

HARTING Middle East FZ-LLC  
Knowledge Village  
Block 2A - Office F72  
P.O. Box: 454372  
Dubai  
Phone +971 4 453 9737  
uae@HARTING.com

**HARTING Inc. of North America**

1370 Bowes Road  
USA-Elgin, Illinois 60123  
Phone +1 847 741 1500  
us@HARTING.com



## Other countries and general contact



HARTING  
Electric GmbH & Co. KG

P.O. Box 1473  
D-32328 Espelkamp  
Germany

Phone +49 5772/47-97100

[electric@HARTING.com](mailto:electric@HARTING.com)  
[www.HARTING.com](http://www.HARTING.com)

HARTING  
Electronics GmbH

P.O. Box 1433  
32328 Espelkamp  
Germany

Phone +49 5772/47-97200

[electronics@HARTING.com](mailto:electronics@HARTING.com)  
[www.HARTING.com](http://www.HARTING.com)



Pushing Performance

**HARTING.com** –  
the gateway to your  
country website.

---